

# DC/AC converter (Inverter)

The **inverter** is a **DC/AC converter**. It converts a DC power supply of the input in a sine (AC) power output.

The inverters are widely used for uninterruptible power supply (UPS) and AC motors. By using as input block a **rectifier bridge** they can also convert the constant amplitude and frequency AC power of the main grid, in a variable AC power of given amplitude and frequency, to control the speed and power of AC motors (**AC/AC converters**).

The basic scheme is based on the bridge converter configuration, operating in the **bipolar** switching mode. To obtain a sine output voltage  $V_{ABav}$  we need to vary the duty cycle  $D_1$  in time according to the sine waveform. The frequency  $f_s$  of the sinusoidal output must be obviously much less than the switching frequency  $f_M = 1/T$ , to allow a good filtering of  $f_M$  with LC filter, while leaving unaltered the  $f_s$  of the sine output.

To obtain the above a PWM modulation is used, as described before, by comparing a sawtooth signal at a frequency  $f_M$  (that corresponds to the frequency  $1/T$  that opens and closes the switches) with a sine  $f_s$  that corresponds to the control signal.

Again one must note that if an AC output of a relatively high frequency  $f_s$  is needed (say above some KHz) the switching frequency for a good filtering must be in the range of some hundreds of KHz, and that poses a challenge for the power devices needed.



Here it is schematically indicated the PWM scheme needed to obtain a sine output from a bridge converter.

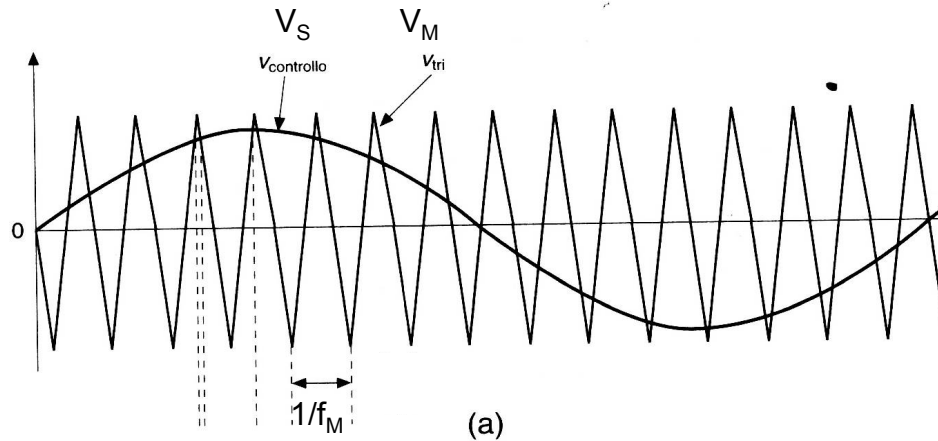

The  $T_{A+}$  and  $T_{B-}$  switches are driven by the comparator output (while the  $T_{A-}$  and  $T_{B+}$  by the inverted one). The comparator makes a comparison between the  $V_S$  and  $V_M$  waveforms and gives the waveform (b)

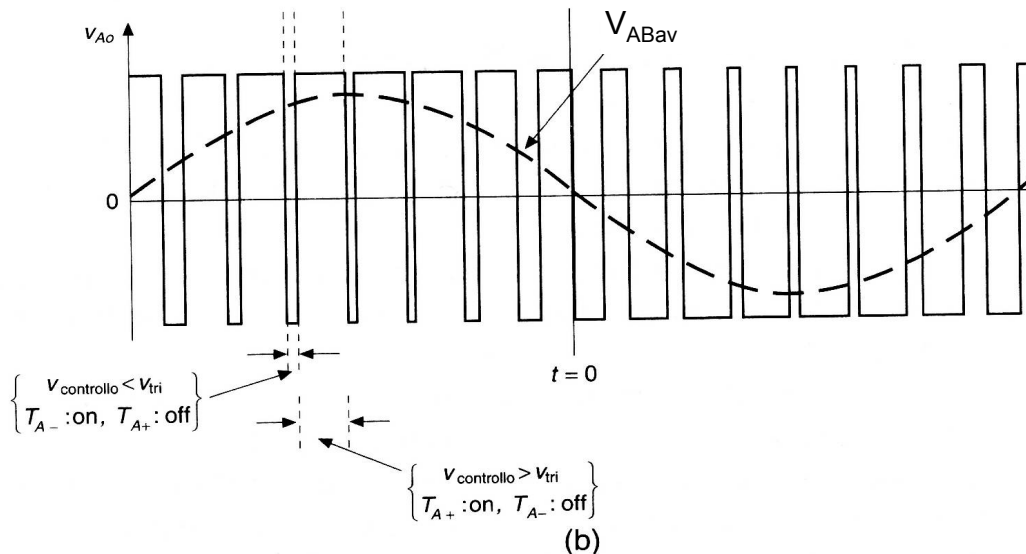

For  $V_S > V_M$   $T_{A+}$  (and  $T_{B-}$ ) is closed and  $V_{AB} = V_i$

For  $V_S < V_M$   $T_{B+}$  (and  $T_{A-}$ ) is closed and  $V_{AB} = -V_i$

The modulation frequency  $f_M$  (and his harmonics) is filtered from the output leaving the sine waveform  $V_{ABav}$ .

# Schematic of a Bridge DC/AC Converter with Power MOS

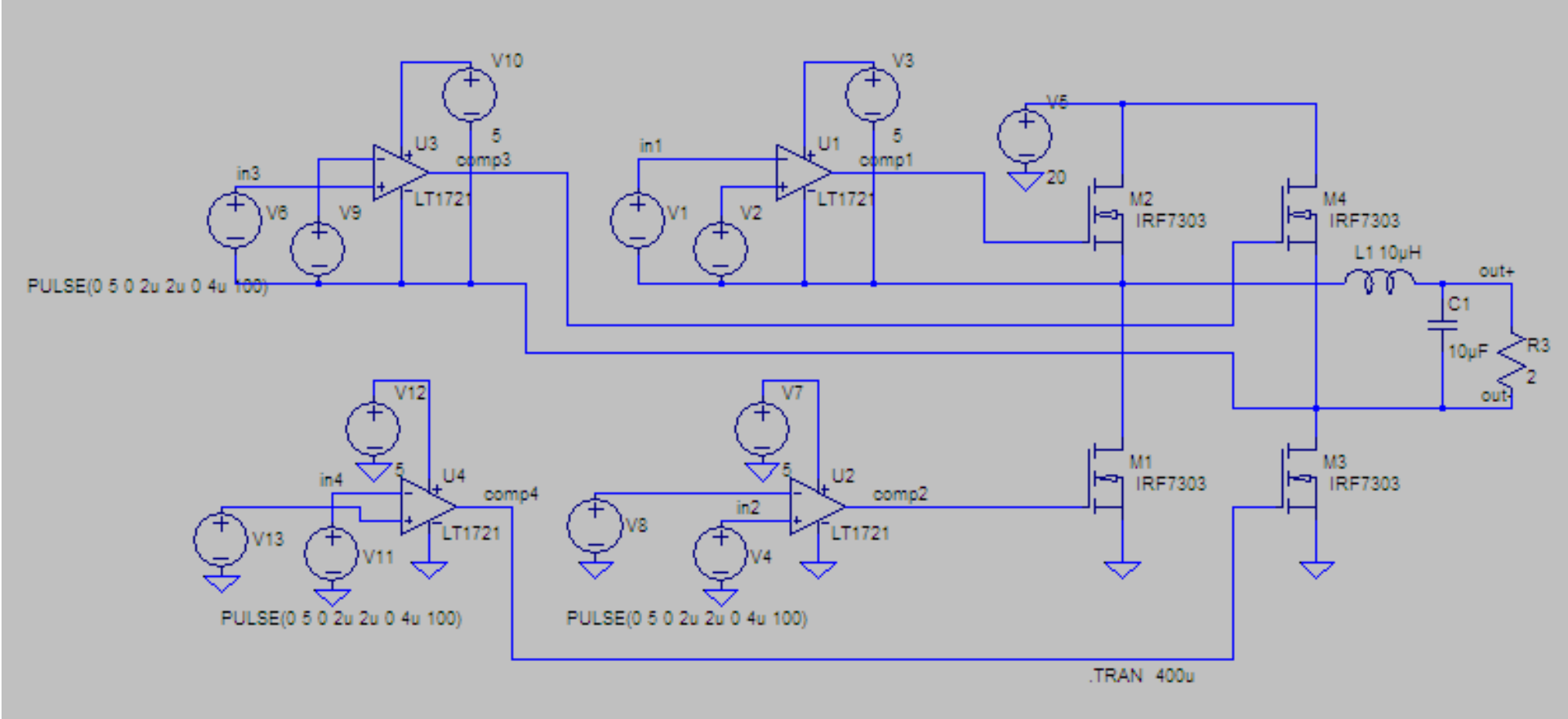

Here is presented, as an example, the power integration realized for a commercial 3 phase inverter contained in a single package, together with the IC driver, all components connected in a plastic board .

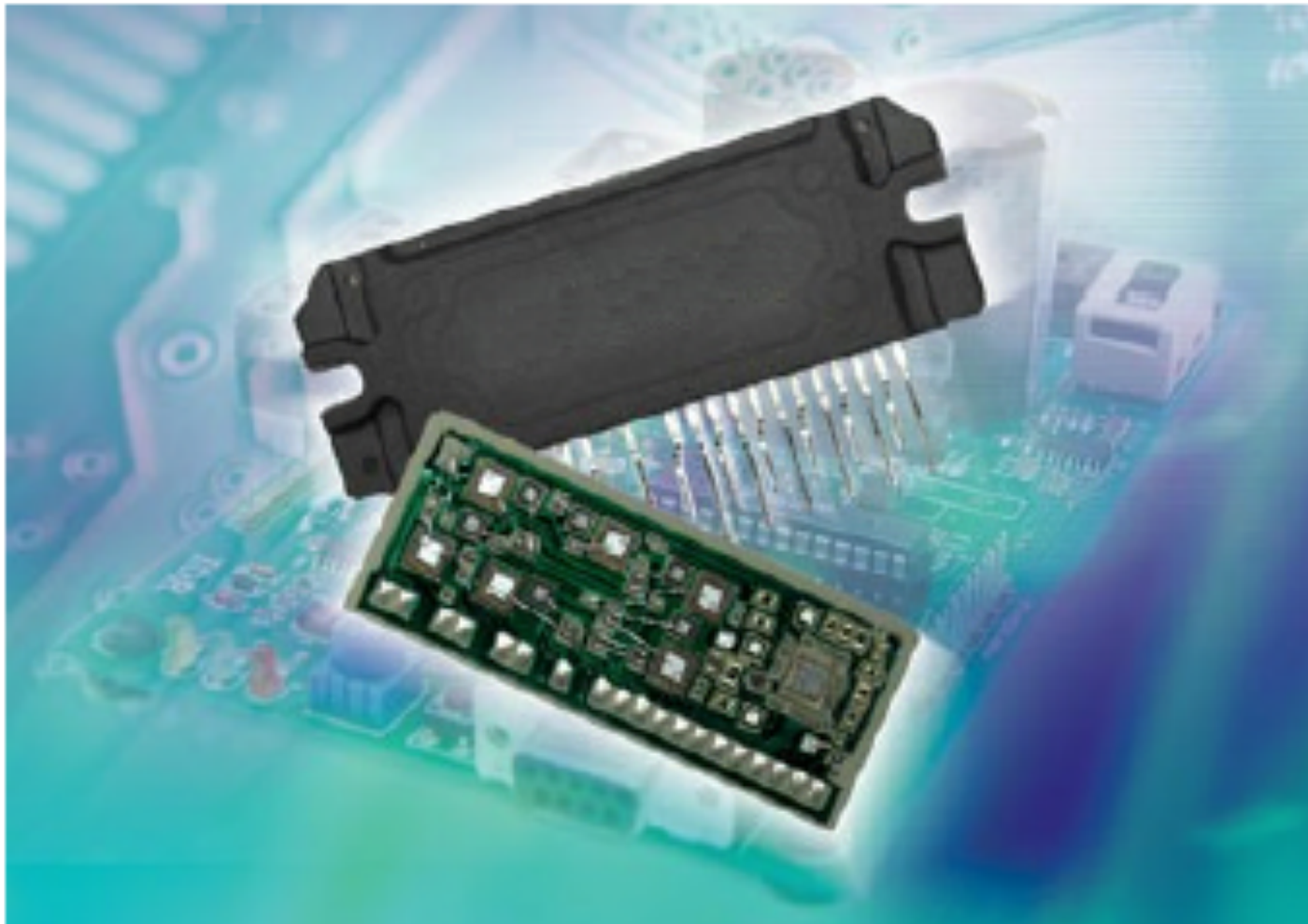



Each of the 3 arms of the bridge are realized as shown here, with an IC driver made with bootstrapping technique, that drives both the high side switch and the low side one

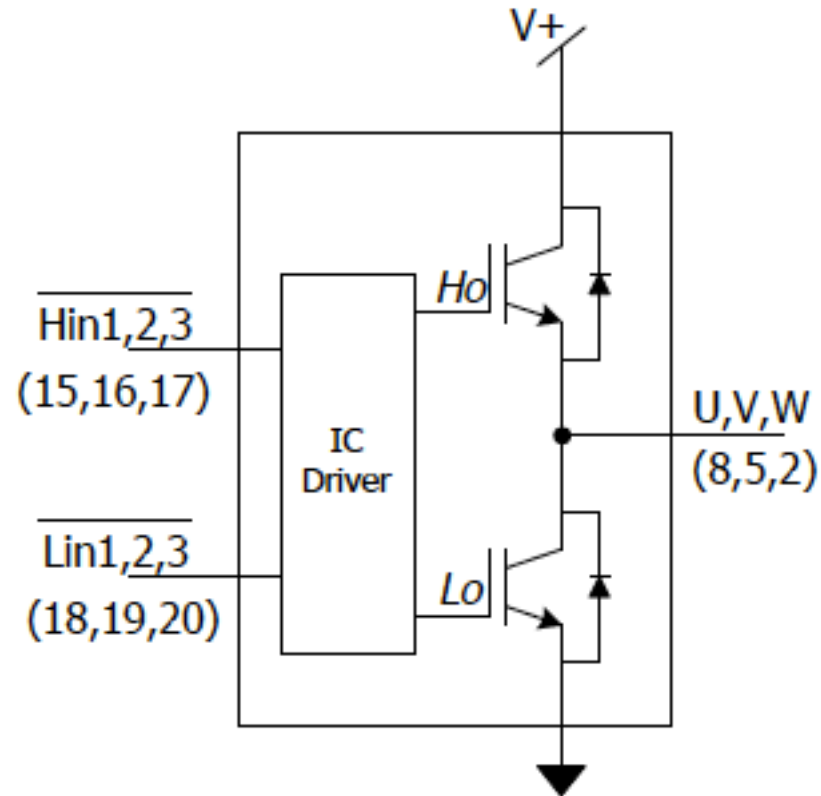

Example of an application of this inverter (contained in the blue dashed line box) as motor drive

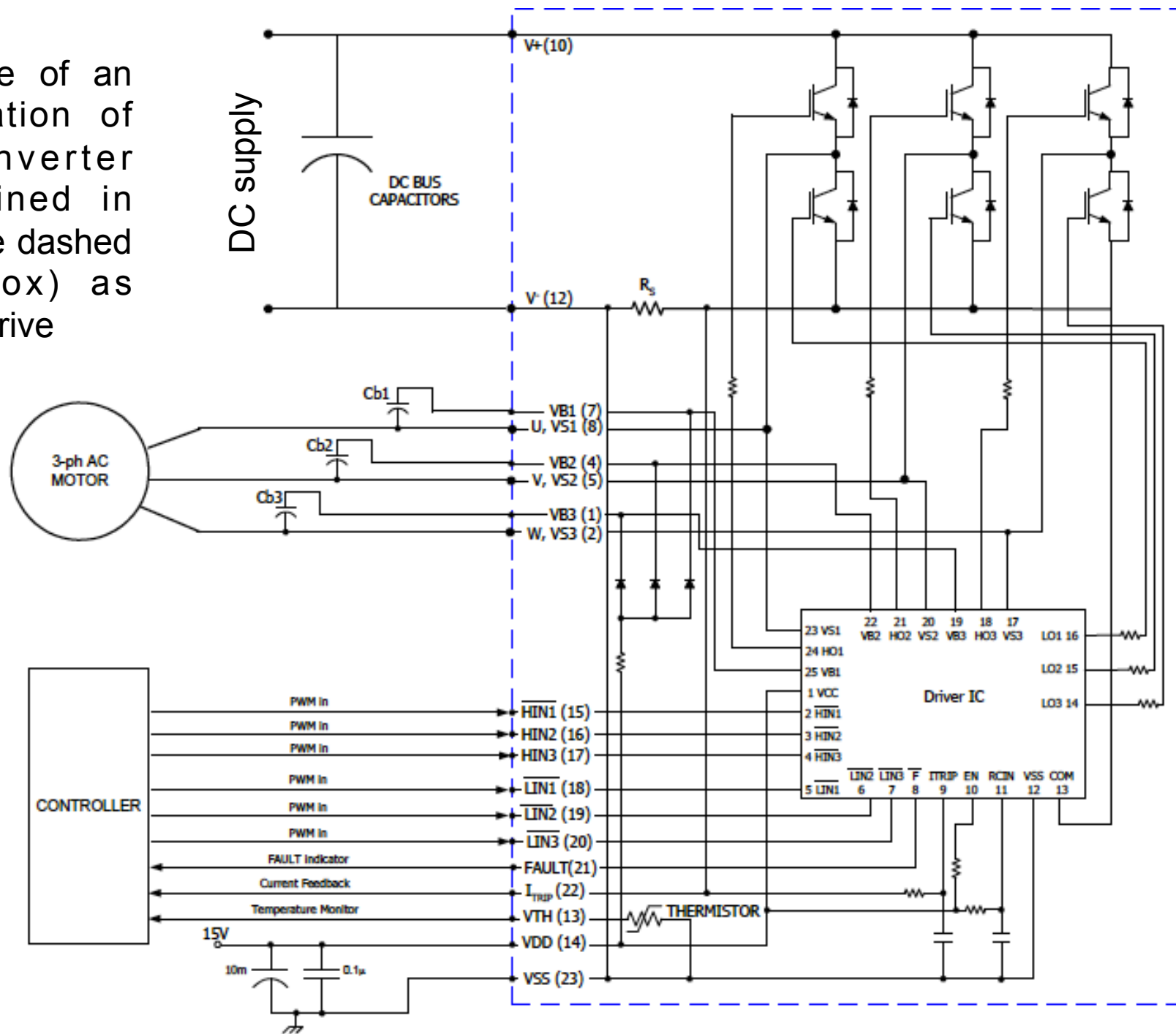

# SWCAD Example of mode of operation for bridge inverter

