

Chapter 5

Ferromagnetism

1. Mean field theory
2. Exchange interactions
3. Band magnetism
4. Beyond mean-field theory
5. Anisotropy
6. Ferromagnetic phenomena



Comments and corrections please: jcoey@tcd.ie

I. Mean field theory

The characteristic feature of ferromagnetic order is spontaneous magnetisation \mathbf{M}_s due to spontaneous alignment of atomic magnetic moments, which disappears on heating above a critical temperature known as the *Curie point*. The magnetization tends to lie along certain *easy directions* determined by crystal structure (magnetocrystalline anisotropy) or sample shape.

I.1 Molecular field theory

Weiss (1907) supposed that in addition to any externally applied field \mathbf{H} , there is an internal ‘molecular’ field in a ferromagnet proportional to its magnetization.

$$\mathbf{H}^i = n_W \mathbf{M}_s$$

\mathbf{H}^i must be immense in a ferromagnet like iron to be able to induce a significant fraction of saturation at room temperature; $n_W \approx 100$. The origin of these huge fields remained a mystery until Heisenberg introduced the idea of the exchange interaction in 1928.

Magnetization is given by the Brillouin function, $\langle m \rangle = m \mathcal{B}_J(x)$ where $x = \mu_0 m H^i / k_B T$.
 The spontaneous magnetization at nonzero temperature $M_s = N \langle m \rangle$ and $M_0 = N m$.

In zero external field, we have

$$M_s/M_0 = \mathcal{B}_J(x) \quad (1)$$

But also by eliminating H^i from the expressions for H^i and x ,

$$M_s/M_0 = (N k_B T / \mu_0 M_0^2 n_W) x$$

which can be rewritten in terms of the Curie constant $C = \mu_0 N g^2 \mu_B^2 J(J+1) / 3 k_B$.

$$M_s/M_0 = [T(J+1) / 3C] n_W x \quad (2)$$

The simultaneous solution of (1) and (2) is found *graphically*, or numerically.

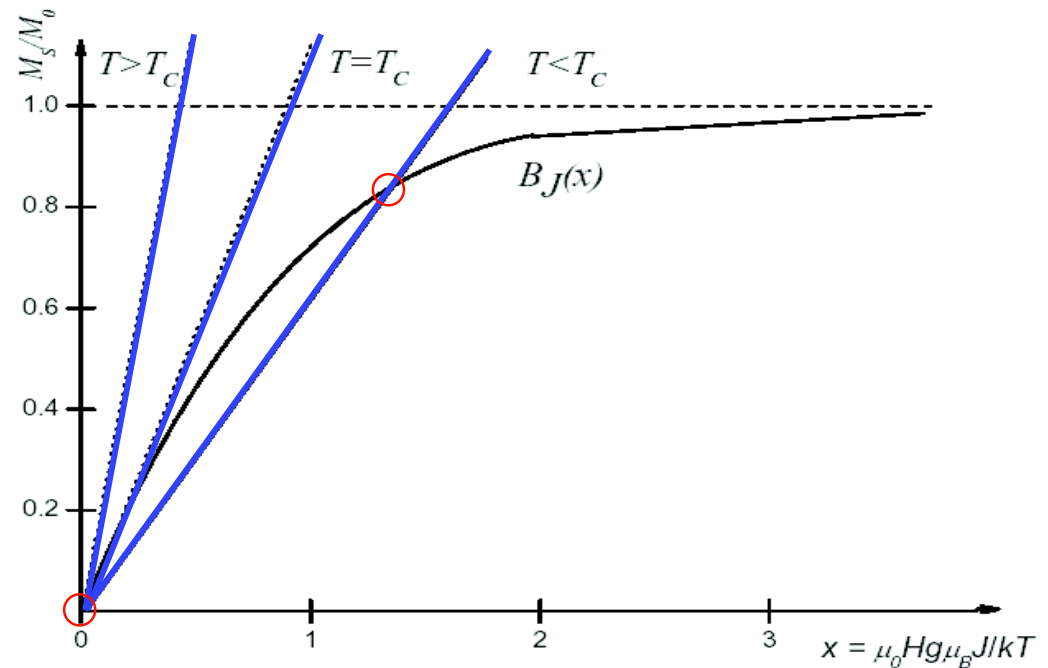

Graphical solution of (1) and (2) for $J = 1/2$ to find the spontaneous magnetization M_s when $T < T_C$.
 Eq. (2) is also plotted for $T = T_C$ and $T > T_C$.

At the Curie temperature, the slope of (2) is equal to the slope at the origin of the Brillouir function

For small x.

$$\mathcal{B}_J(x) \approx [(J+1)/3]x + \dots$$

hence

$$T_C = n_W C$$

where the Curie constant $C \approx I K$

A typical value of T_C is a few hundred Kelvin. In practice, T_C is used to determine n_W .

In the case of Gd, $T_C = 292$ K, $J = S = 7/2$;
 $g = 2$; $N = 3.0 \cdot 10^{28} \text{ m}^{-3}$; hence $C = 4.9$ K, $n_W = 59$;
 The value of $M_0 = Ng\mu_B J$ is 1.95 MA m^{-1} .
 Hence $\mu_0 H_i = 144$ T.

The spontaneous magnetization for nickel, together with the theoretical curve for $S = 1/2$ from the mean field theory. The theoretical curve is scaled to give correct values at either end.

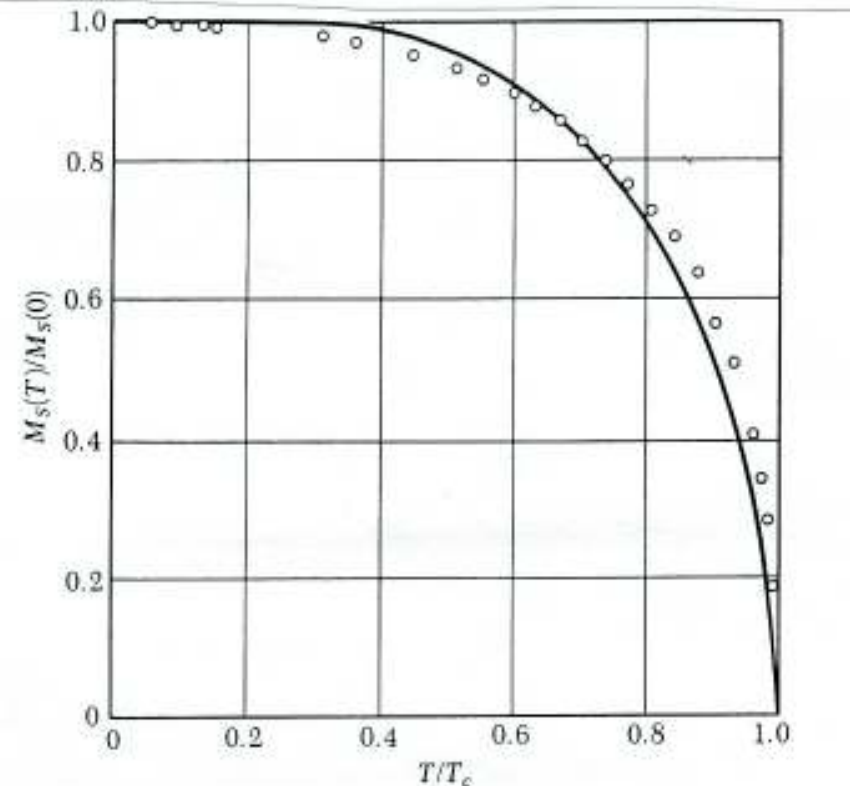

Temperature dependence

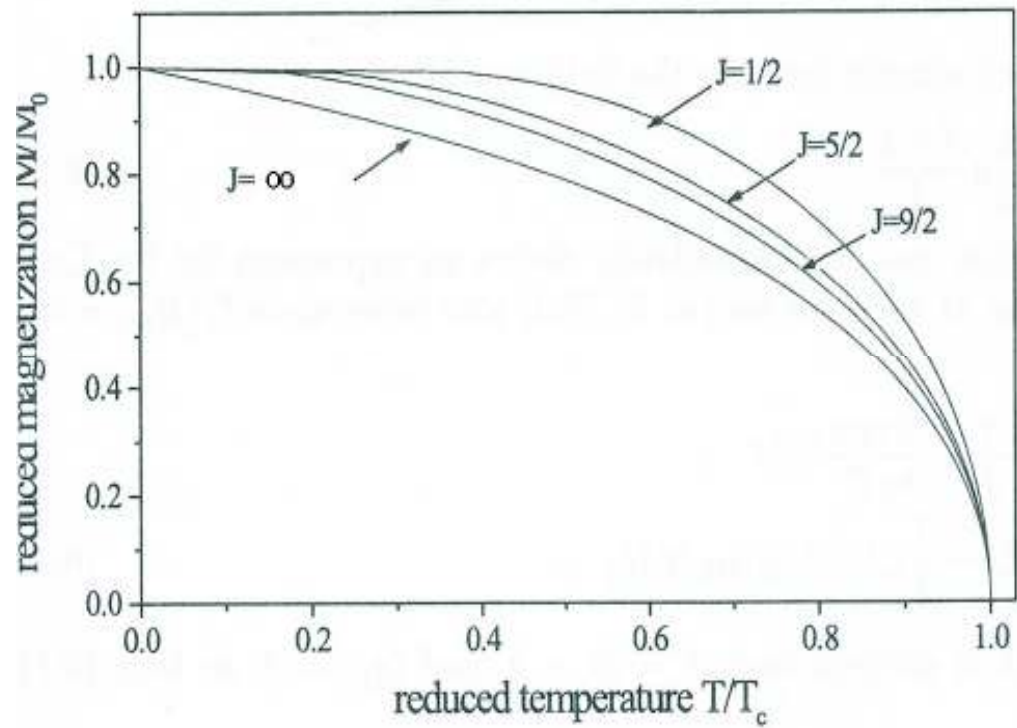

$T > T_C$

The paramagnetic susceptibility above T_C is obtained from the linear term $\mathcal{B}_j(x) \approx [(j+1)/3]x$ with $x = \mu_0 m(n_W M + H)/k_B T$. The result is the *Curie-Weiss law*

$$\chi = C/(T - \theta_p)$$

where $\theta_p = T_C = \mu_0 n_W N g^2 \mu_B^2 J(J+1)/3k_B = C n_W$

In this theory, the paramagnetic Curie temperature θ_p is equal to the Curie temperature T_C which is where the susceptibility *diverges*.

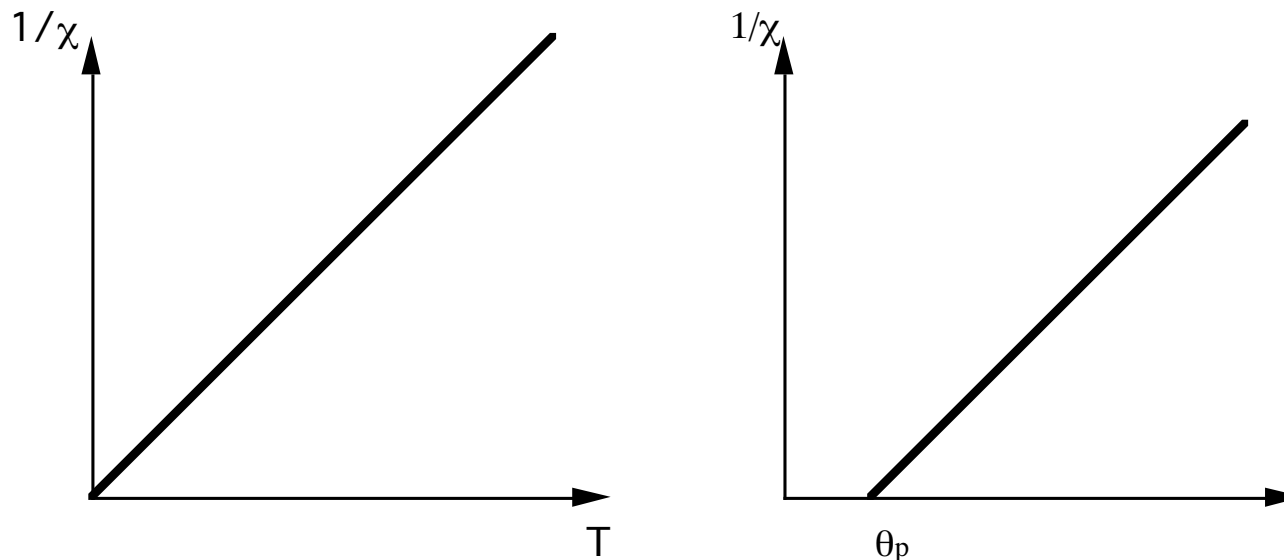

The Curie-law susceptibility of a paramagnet (left) compared with the Curie-Weiss susceptibility of a ferromagnet (right).

Critical behaviour

In the vicinity of the phase transition at T_c there are singularities in the behaviour of the physical properties – susceptibility, magnetization, specific heat etc. These vary as power laws of reduced temperature $\varepsilon = (T-T_c)/T_c$ or applied field.

Expanding the Brillouin function in the vicinity of T_c yields

$$H = cM(T-T_c) + aM^3 + \dots$$

Hence, at T_c $M \sim H^{1/\delta}$ with $\delta = 3$ (critical isotherm)

Below T_c $M \sim (T-T_c)^\beta$ with $\beta = 1/2$

Above T_c $M/H \sim (T-T_c)^\gamma$ with $\gamma = -1$ (Curie law)

At T_c the specific heat $d(-MH^i)/dT$ shows a discontinuity $C \sim (T-T_c)^\alpha$; $\alpha = 0$

The numbers $\alpha \beta \gamma \delta$ are *static critical exponents*.

Only two of these are independent, because there are only two independent thermodynamic variables H and T in the partition function.

Relations between them are $\alpha + 2\beta + \gamma = 2$; $\gamma = \beta(\delta - 1)$

1.2 Landau theory

A general approach to phase transitions is due to Landau. He writes an series expansion for the free energy close to T_C , where M is small

$$G_L = a_2 M^2 + a_4 M^4 + \dots - \mu_0 H M$$

When $T < T_C$ an energy minimum $M = \pm M_s$ means $a_2 < 0$; $a_4 > 0$

When $T > T_C$ an energy minimum $M = 0$ means $a_2 > 0$; $a_4 > 0$

Hence $a_2 = c (T - T_C)$. Minimizing G_L gives an expression for M

$$2a_2 M + 4a_4 M^3 + \dots = \mu_0 H.$$

Hence the same critical exponents are found as for molecular field theory.

Any mean-field theory gives the same results

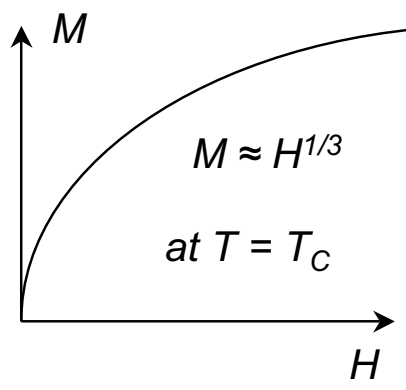
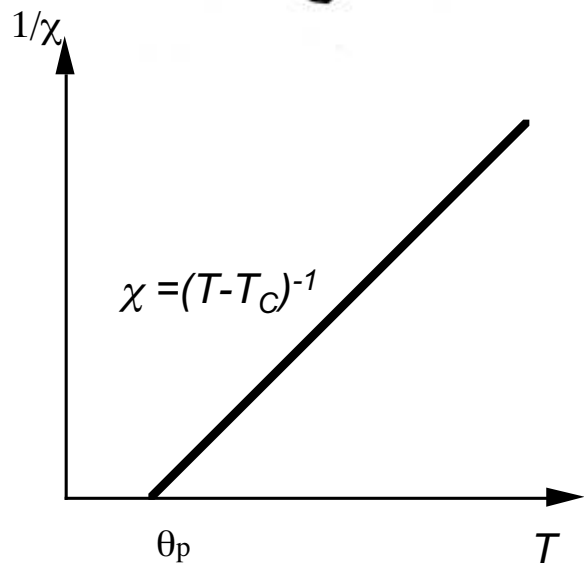
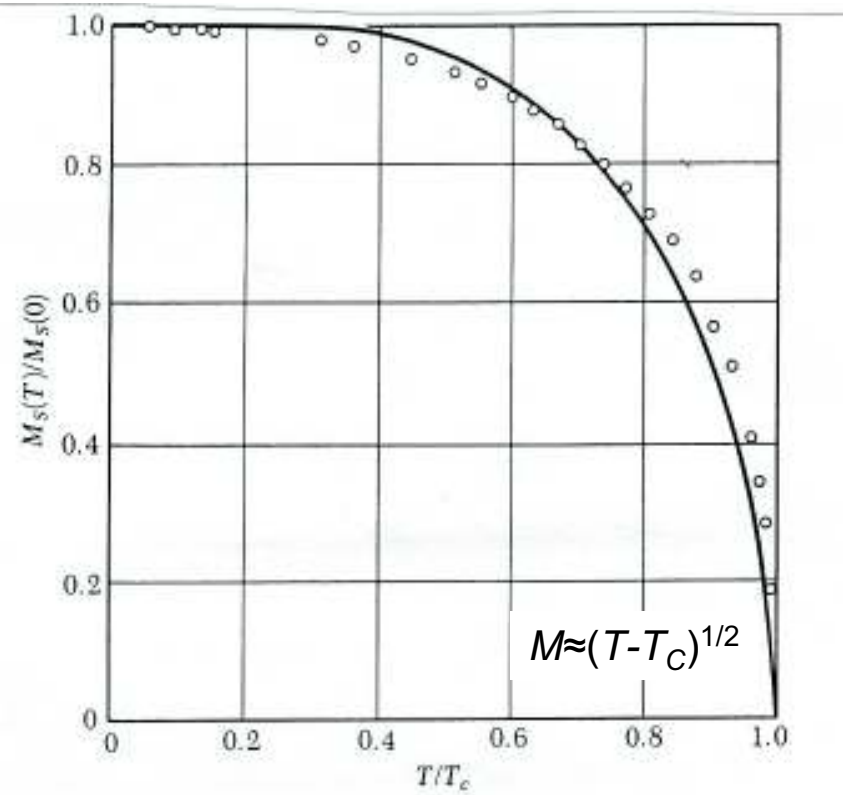
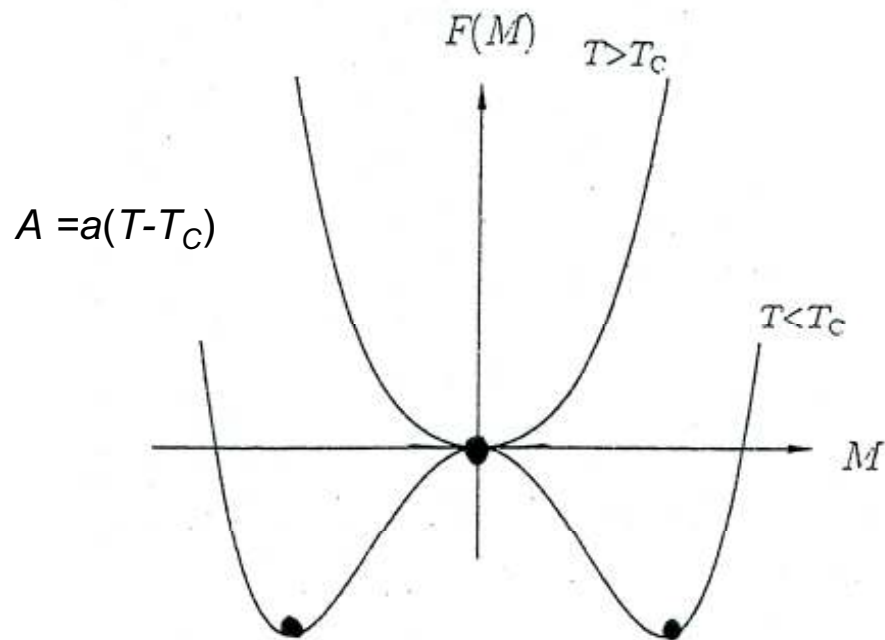

	α	β	γ	δ
Mean field	0	1/2	1	3
3d Heisenberg	-1.115	0.362	1.39	4.82
2d Ising	0	1/8	7/4	15

Experiment is close to this

$$G_L = AM^2 + BM^4 + \dots - \mu_0 H' M$$

minimizes G_L with respect to M ; $\partial G_L / \partial M = 0$

$$2AM + 4BM^3 = \mu_0 H' \tag{5.9}$$

Close to T_C , in zero field, $M_s^2 = -A/2B$, hence

$$M_s \approx \sqrt{a/2B}(T_C - T)^{\frac{1}{2}} \tag{5.10}$$

as shown in Fig 5.2. The Curie-Weiss susceptibility M/H' is given by (5.9) as $\mu_0/2a$

$$\chi \approx (\mu_0/2a)(T - T_C)^{-1} \tag{5.11}$$

When the system is at a temperature exactly equal to T_C , $A = 0$ and (5.9) gives the critical isotherm

$$M = (\mu_0/4B)H'^{1/3} \tag{5.12}$$

whereas in the vicinity of T_C ,

$$M^2 = (\mu_0/4B)H'/M + (a/2B)(T - T_C) \tag{5.13}$$

This last equation is the basis of *Arrott-Belov plots* used for precise determination of the Curie temperature of a ferromagnet. M^2 is plotted versus H'/M and the isotherm that extrapolates to zero is the one at T_C . (Fig 5.4).

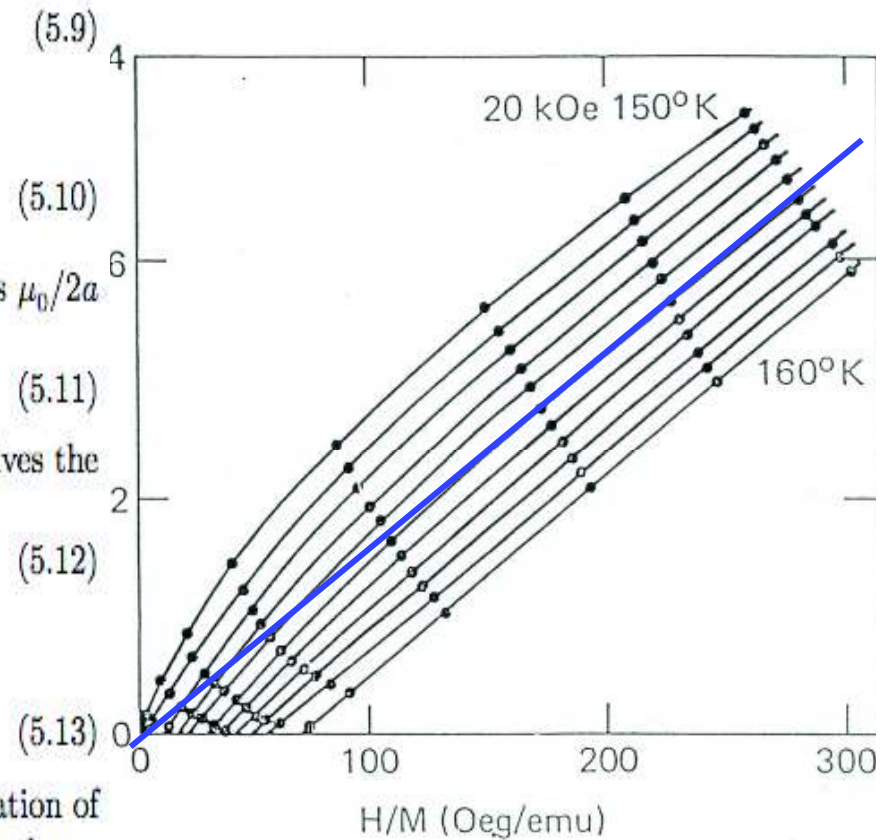

Arrott plots

1.3 Stoner criterion

Some metals have narrow bands and a large density of states at the Fermi level; This leads to a large Pauli susceptibility $\chi_{\text{Pauli}} \approx 2\mu_0 N(E_F)\mu_B^2$.

When χ_{Pauli} is large enough, it is possible for the band to split *spontaneously*, and ferromagnetism appears.

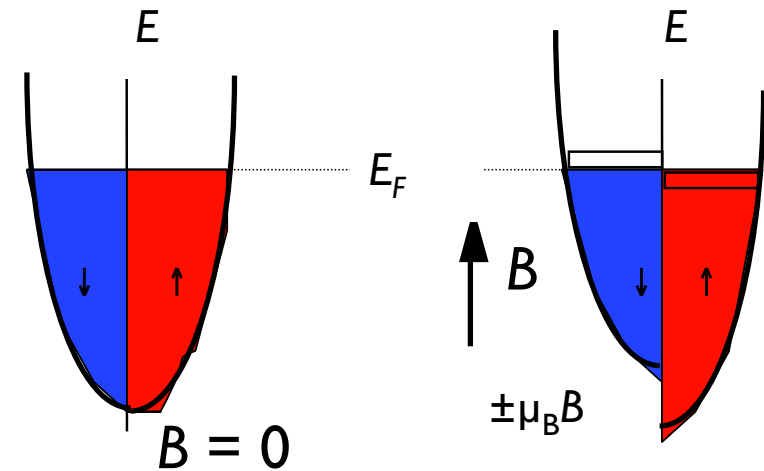
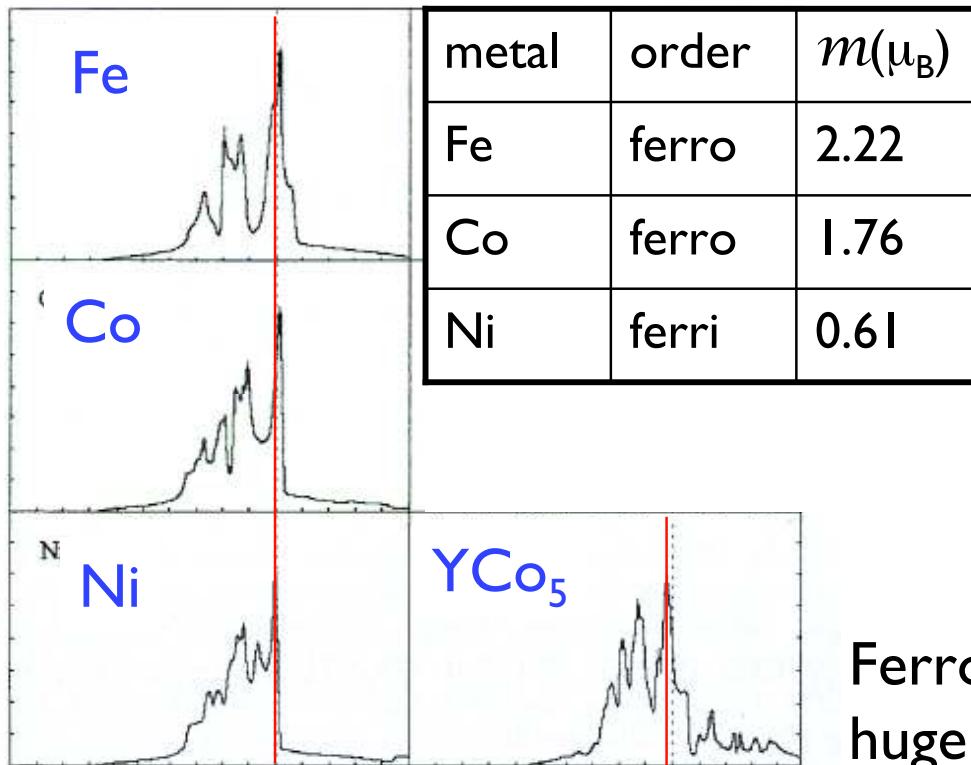

$$M = (N^\uparrow - N^\downarrow)\mu_B$$

$$N^{\uparrow,\downarrow} = \int_{E_F}^{\infty} N^{\uparrow,\downarrow}(E)dE$$

Ferromagnetic metals and alloys all have a huge peak in the density of states at E_F

Ferromagnetic exchange in metals does not always lead to spontaneous ferromagnetic order. The Pauli susceptibility must exceed a certain threshold. There must be an exceptionally large density of states at the Fermi level $N(E_F)$. Stoner applied Pierre Weiss's molecular field idea to the free electron model.

$$\mathbf{H}^i = n_s \mathbf{M}$$

Here n_s is the Weiss constant; The total internal field acting is $\mathbf{H} + n_s \mathbf{M}$. The Pauli susceptibility $\chi_p = M/(H + n_s M)$ is enhanced: The response to the applied field

$$\chi = M/H = \chi_p / (1 - n_s \chi_p)$$

Hence the susceptibility *diverges* when $n_s \chi_p > 1$. The \uparrow and \downarrow bands split spontaneously, The value of n_s is about 10,000 in 3d metals.

The Pauli susceptibility is proportional to the density of states $N(E_F)$. Only metals with a huge peak in $N(E)$ at E_F can order ferromagnetically.

Stoner expressed the criterion for ferromagnetism in terms of the density of states at the Fermi level $N(E_F)$ (proportional to χ_p) and an exchange parameter \mathcal{I} (proportional to n_W).

Writing the exchange energy per unit volume as $-(1/2)\mu_0 H_i M = -(1/2)\mu_0 n_W M^2$ and equating it to the Stoner expression

$$-(\mathcal{I}/4)(N^\uparrow - N^\downarrow)^2$$

Gives the result $\mathcal{I} = 2\mu_0 n_W \mu_B^2$. Hence the criterion $n_W \chi_p > 1$ can be written

$$\mathcal{I}_0 N(E_F) > 1$$

\mathcal{I} is about 0.6 eV for the early 3d elements and 1.0 eV for the late 3d elements

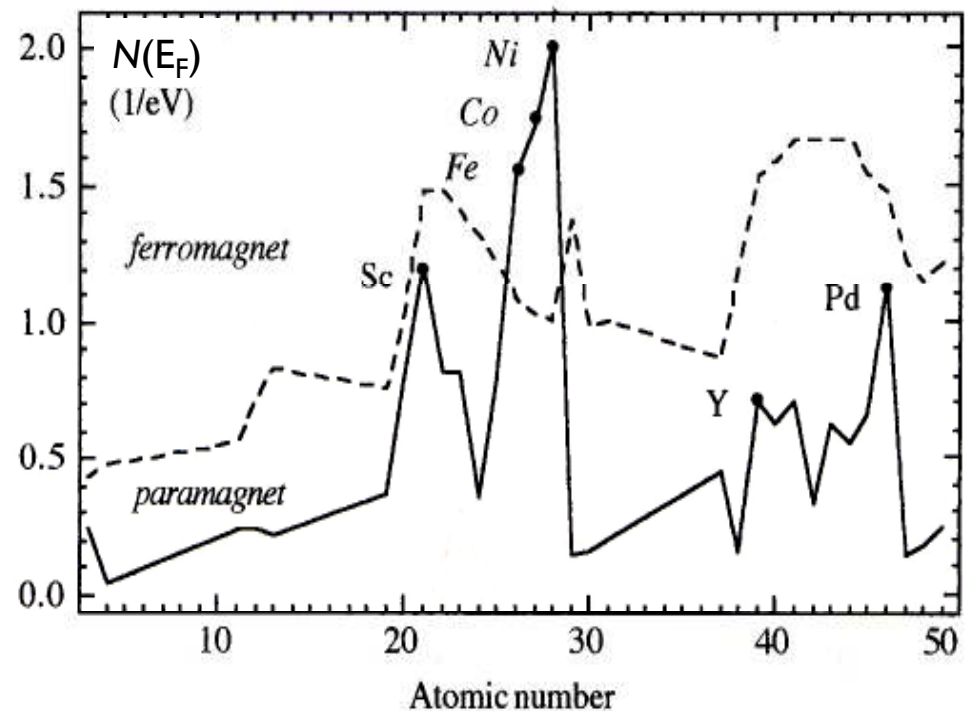

2. Exchange interactions

What is the origin of the effective magnetic fields of ~ 100 T which are responsible for ferromagnetism? They are *not* due to the atomic magnetic dipoles. The field at distance r due to a dipole \mathbf{m} is

$$\mathbf{B}_{\text{dip}} = (\mu_0 m / 4\pi r^3) [2\cos\theta \mathbf{e}_r + \sin\theta \mathbf{e}_\theta].$$

The order of magnitude of $B_{\text{dip}} = \mu_0 H_{\text{dip}}$ is $\mu_0 m / 4\pi r^3$; taking $m = 1\mu_B$ and $r = 0.1$ nm gives $B_{\text{dip}} = 4\pi \cdot 10^{-7} \times 9.27 \cdot 10^{-24} / 4\pi \cdot 10^{-30} \approx 1$ tesla. Summing all the contributions of the neighbours on a lattice does *not* change this order of magnitude; in fact the dipole sum for a cubic lattice is exactly zero!

The origin of the internal field \mathbf{H}^i is the exchange interaction, which reflects the electrostatic Coulomb repulsion of electrons on neighbouring atoms and the Pauli principle, which forbids two electrons from entering the same quantum state. There is an energy difference between the $\uparrow\downarrow$ and $\uparrow\uparrow$ configurations for the two electrons. Inter-atomic exchange is one or two orders of magnitude weaker than the intra-atomic exchange which leads to Hund's first rule.

The Pauli principle requires the total wave function of two electrons 1,2 to be *antisymmetric* on exchanging two electrons

$$\Phi(1,2) = -\Phi(2,1)$$

The total wavefunction is the product of functions of space and spin coordinates $\Psi(\mathbf{r}_1, \mathbf{r}_2)$ and $\chi(s_1, s_2)$, each of which must be either symmetric or antisymmetric. This follows because the electrons are indistinguishable particles, and the number in a small volume dV can be written as $\Psi^2(1,2)dV = \Psi^2(2,1)dV$, hence $\Psi(1,2) = \pm \Psi(2,1)$.

The simple example of the **hydrogen molecule** H_2 with two atoms a,b with two electrons 1,2 in hydrogenic 1s orbitals ψ_i gives the idea of the physics of exchange. There are two molecular orbits, one spatially symmetric Ψ_S , the other spatially antisymmetric Ψ_A .

$$\Psi_S(1,2) = (1/\sqrt{2})(\psi_{a1}\psi_{b2} + \psi_{a2}\psi_{b1}); \quad \Psi_A(1,2) = (1/\sqrt{2})(\psi_{a1}\psi_{b2} - \psi_{a2}\psi_{b1})$$

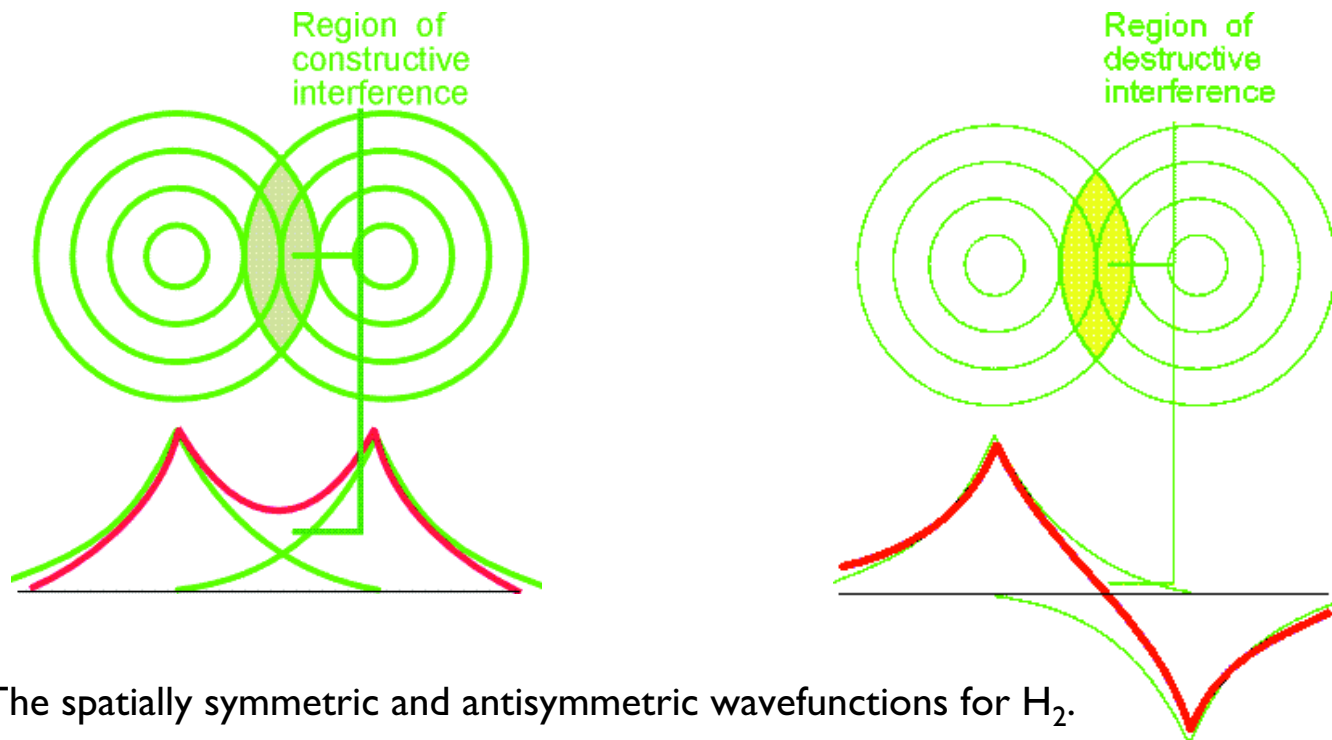

The spatially symmetric and antisymmetric wavefunctions for H_2 .

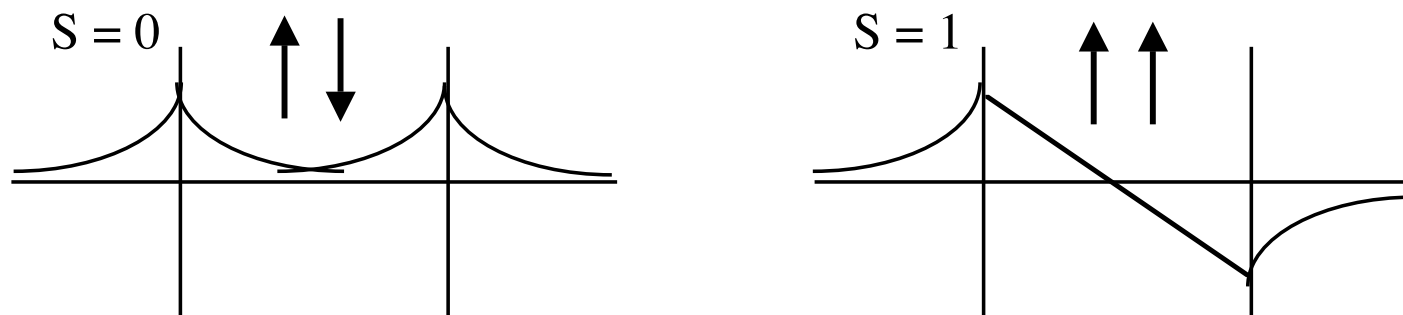

The symmetric and antisymmetric spin functions are the spin triplet and spin singlet states

$$\chi_S = |\uparrow_1, \uparrow_2\rangle; \quad (1/\sqrt{2})[|\uparrow_1, \downarrow_2\rangle + |\downarrow_1, \uparrow_2\rangle]; \quad |\downarrow_1, \downarrow_2\rangle. \quad S = 1; M_S = 1, 0, -1$$

$$\chi_A = (1/\sqrt{2})[|\uparrow_1, \downarrow_2\rangle - |\downarrow_1, \uparrow_2\rangle] \quad S = 0; M_S = 0$$

According to Pauli, the symmetric space function must multiply the antisymmetric spin function, and vice versa. Hence the total wavefunctions are

$$\Phi_I = \Psi_S(1,2)\chi_A(1,2); \quad \Phi_{II} = \Psi_A(1,2)\chi_S(1,2)$$

The energy levels can be evaluated from the Hamiltonian $H(\mathbf{r}_1, \mathbf{r}_2)$

$$E_{I,II} = \int \Psi_{S,A}^*(\mathbf{r}_1, \mathbf{r}_2) \mathcal{H}(\mathbf{r}_1, \mathbf{r}_2) \Psi_{S,A}(\mathbf{r}_1, \mathbf{r}_2) d\mathbf{r}_1 d\mathbf{r}_2$$

With no interaction of the electrons on atoms a and b, $H(\mathbf{r}_1, \mathbf{r}_2)$ is just $\mathcal{H}_0 = (-\hbar^2/2m)\{\nabla_1^2 + \nabla_2^2\} + V_1 + V_2$.

The two energy levels E_I , E_{II} are degenerate, with energy E_0 . However, if the electrons interact via a term $\mathcal{H} = e^2/4\pi\epsilon_0 r_{12}^{-2}$, we find that the perturbed energy levels are $E_I = E_0 + 2J$, $E_{II} = E_0 - 2J$. The exchange integral is

$$J = \int \psi_{a1}^* \psi_{b2}^*(\mathbf{r}) \mathcal{H}(r_{12}) \psi_{a2} \psi_{b1}(\mathbf{r}) d\mathbf{r}_1 d\mathbf{r}_2$$

and the separation ($E_{II} - E_I$) is $4J$. For the H_2 molecule, E_I lies lower than E_{II} , the *bonding* orbital singlet state lies below the *antibonding* orbital triplet state J is negative. The tendency for electrons to pair off in bonds with opposite spin is everywhere evident in chemistry; these are the covalent interactions. We write the spin-dependent energy in the form

$$E = -2(J'/\hbar^2) \mathbf{s}_1 \cdot \mathbf{s}_2$$

The operator $\mathbf{s}_1 \cdot \mathbf{s}_2$ is $1/2[(\mathbf{s}_1 + \mathbf{s}_2)^2 - \mathbf{s}_1^2 - \mathbf{s}_2^2]$. According to whether $S = s_1 + s_2$ is 0 or 1, the eigenvalues are $-(3/4)\hbar^2$ or $-(1/4)\hbar^2$. The splitting between the $\uparrow\downarrow$ singlet state (I) and the $\uparrow\uparrow$ triplet state (II) is then J' .

Energy splitting between the singlet and triplet states for hydrogen.

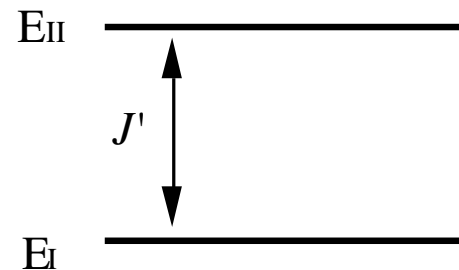

Heisenberg generalized this to many-electron atomic spins S_1 and S_2 , writing his famous Hamiltonian, where \hbar is absorbed into the J .

$$\mathcal{H} = -2J\mathbf{S}_1 \cdot \mathbf{S}_2$$

$J > 0$ indicates a ferromagnetic interaction (favouring $\uparrow\uparrow$ alignment).

$J < 0$ indicates an antiferromagnetic interaction (favouring $\uparrow\downarrow$ alignment).

When there is a lattice, the Hamiltonian is generalized to a sum over all pairs i,j , $-2\sum_{i>j} J_{ij}\mathbf{S}_i \cdot \mathbf{S}_j$. This is simplified to a sum with a single exchange constant J if only nearest-neighbour interactions count.

The Heisenberg exchange constant J can be related to the Weiss constant n_W in the molecular field theory. Suppose the moment $g\mu_B S_i$ interacts with an effective field $H^i = n_W M = n_W N g \mu_B S$ and that in the Heisenberg model only the nearest neighbours of S_i have an appreciable interaction with it. Then the site Hamiltonian is

$$\mathcal{H}_i = -2(\sum_j J \mathbf{S}_j) \cdot \mathbf{S}_i \approx -H^i g \mu_B S_i$$

The molecular field approximation amounts to neglecting the local correlations between \mathbf{S} and \mathbf{S}_j . If Z is the number of nearest neighbours in the sum, then $J = n_W N g^2 \mu_B^2 / 2Z$. Hence from the expression for T_C in terms of the Weiss constant n_W

$$T_C = 2ZJ(J+1)/3k_B$$

Taking the example of Gd again, where $T_C = 292$ K, $J = 7/2$, $Z = 12$, we find $J/k_B = 2.3$ K.

The exchange interaction couples the *spins*. What happens for the rare earths, where J is the good quantum number ?

e.g. Eu^{3+} $L = 3, S = 3, J = 0$.

Since $\mathbf{L} + 2\mathbf{S} = g\mathbf{J}$, $\mathbf{S} = (g-1)\mathbf{J}$.

Hence $T_C = 2(g-1)^2 J(J+1) \{ZJ\} / 3k$

The quantity $G = (g-1)^2 J(J+1)$ is known as the de Gennes factor. T_C for an isostructural series of rare earth compounds is proportional to G .

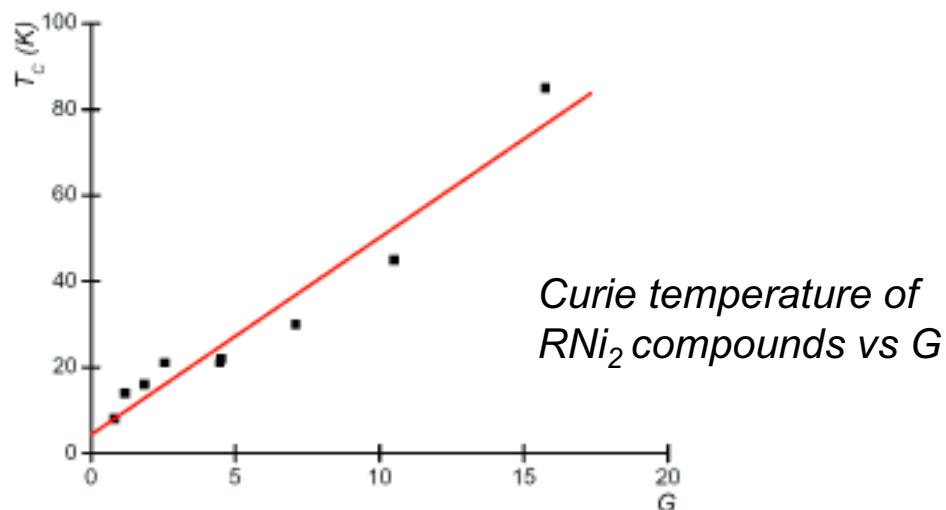

	S	L	J	g(Lande)	G(de Gennes)
La	0	0	0		0
Ce	0.5	3	2.5	0.8571	0.18
Pr	1	5	4	0.8	0.80
Nd	1.5	6	4.5	0.7273	1.84
Pm	2	6	4	0.6	3.20
Sm	2.5	5	2.5	0.2857	4.46
Eu	3	4	0		0
Gd	3.5	0	3.5	2	15.75
Tb	3	3	6	1.5	10.50
Dy	2.5	5	7.5	1.3333	7.08
Ho	2	6	8	1.25	4.50
Er	1.5	6	7.5	1.2	2.55
Tm	1	5	6	1.1667	1.17
Yb	0.5	3	3.5	1.1429	0.32
Lu	0	0	0		0

Exchange in models.

Mott - Hubbard insulator.

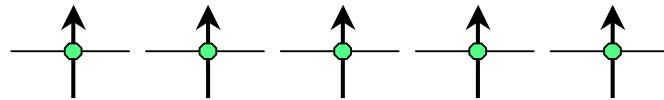

No transfer is possible

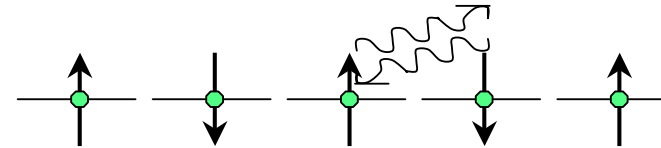

Virtual transfer: $\Delta E = -2t^2/U$

$t \approx 0.2 \text{ eV}$, $U \approx 4 \text{ eV}$, $\Delta E \approx 0.005 \text{ eV}$

$1 \text{ eV} \equiv 11606 \text{ K}$ $\Delta E \approx 60 \text{ K}$

Compare with $-2J \mathbf{S}_i \cdot \mathbf{S}_j$

$\uparrow\uparrow - (1/2)J$

$\uparrow\downarrow + (1/2)J$

$J = -2t^2/U$

Charge-transfer insulator.

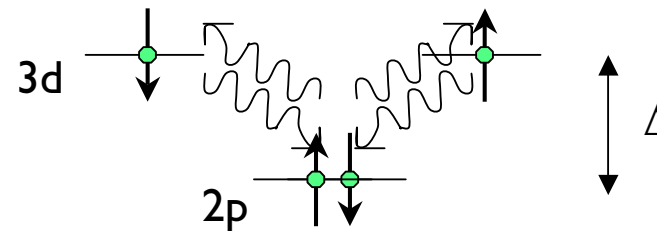

$$J = 2t_{pd}^4 / (\Delta^2(2\Delta + U_{pp}))$$

Superexchange

Superexchange is an indirect interaction between two magnetic cations, via an intervening anion, often $O^{2-} (2p^6)$

$$J = -2t^2/U$$

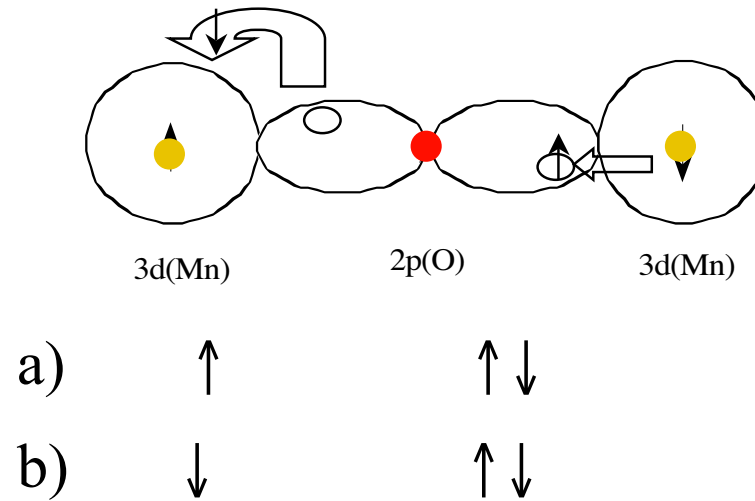



Goodenough-Kanamori rules.

Originally a complex set of semiempirical rules to describe the superexchange interactions in magnetic insulators with different cations M, M' and bond angles θ , covering both kinetic (1-e transfer) and correlation (2-e, 2-centre) interactions....

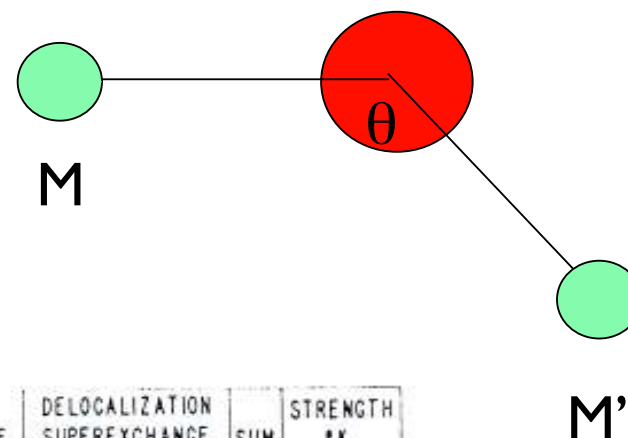

CASE	OUTER-ELECTRON CONFIGURATION	CORRELATION SUPEREXCHANGE		DELOCALIZATION SUPEREXCHANGE		SUM	STRENGTH *K (OXIDES)
		p σ	p π	p σ	p π		
#1		STRONG ↑↑	WEAK ↑↑	STRONG ↑↑	WEAK ↑↑	↑↑	~750
#2		WEAK TO MODERATE ↑↑	WEAK ↑↑	—	WEAK ↑↑	↑↑	≈300
#3		MODERATE ↑↑	WEAK ↑↑	MODERATE ↑↑	WEAK ↑↑	↑↑	~400

A table from 'Magnetism and the Chemical Bond' by J.B. Goodenough

the rules were subsequently simplified by Anderson.

case 1. 180° bonds between half-filled orbitals.

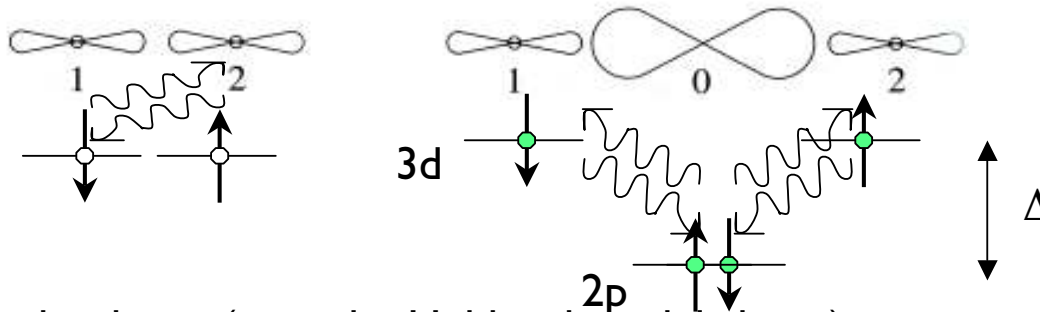

The overlap can be direct (as in the Hubbard model above) or via an intermediate oxygen. In either case the 180° exchange between half-filled orbitals is strong and antiferromagnetic.

case 2. 90° bonds between half-filled orbitals.

Here the transfer is from different p-orbitals. The two p-holes are coupled parallel, according to Hund's first rule. Hence 90° exchange between half-filled orbitals is ferromagnetic and rather weak

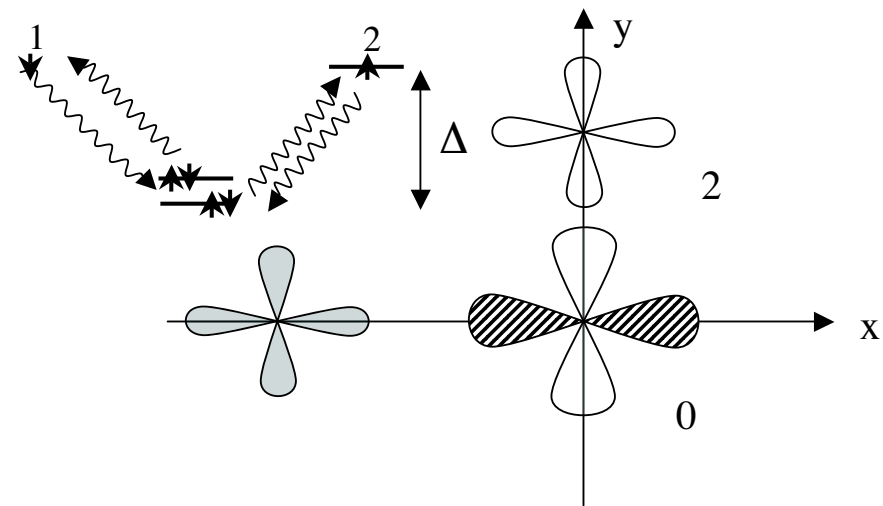

$$J \approx [t_{pd}^4 / (\Delta^2(2\Delta + U_{pp}))][J_{\text{Hund-2p}} / (2\Delta + U_{pp})]$$

Examples of d-orbitals with zero overlap integral (left) and nonzero overlap integral (right). The wave function is positive in the shaded areas and negative in the white areas.

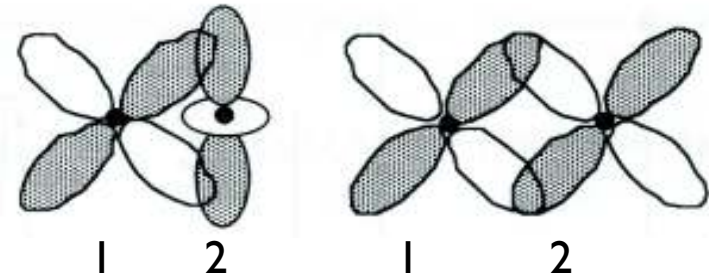

case 3. bonds between half-filled and empty orbitals

Consider a case with orbital order, where there is no overlap between occupied orbitals, as shown on the left above. Now consider electron transfer between the occupied orbital on site 1 and the orbital on site 2, as shown on the right, which is assumed to be unoccupied. The transfer may proceed via an intermediate oxygen. Transfer is possible, and Hund's rule assures a lower energy when the two electrons in different orbitals on site 2 have parallel spins.

Exchange due to overlap between a half-filled and an empty orbital of different symmetry is ferromagnetic and relatively weak.

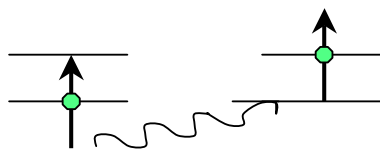

$$\Delta E = -2t^2/(U - J_{\text{hund-3d}})$$

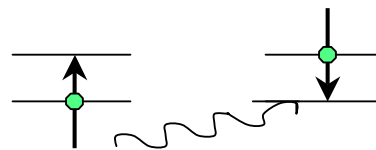

$$\Delta E = -2t^2/U$$

$$J = -(t^2/U)(J_{\text{hund-3d}}/U)$$

Other exchange mechanisms: half-filled orbitals.

– Dzialoshinsky-Moria exchange (Antisymmetric exchange)

This can occur whenever the site symmetry of the interacting ions is uniaxial (or lower). A vector exchange constant \mathbf{D} is defined. (Typically $|\mathbf{D}| \ll |J|$) The D-M interaction is represented by the expression $E_{DM} = -\mathbf{D} \cdot \mathbf{S}_1 \wedge \mathbf{S}_2$. The interaction tends to align the spins perpendicular to each other and to \mathbf{D} which lies along the symmetry axis. Since $|\mathbf{D}| \ll |J|$ and J is usually antiferromagnetic, the D-M interaction tends to produce canted antiferromagnetic structures.

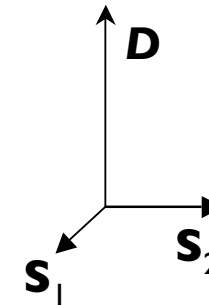

– Biquadratic exchange

This is another weak interaction, represented by

$$E_{bq} = -J_{bq}(\mathbf{S}_1 \cdot \mathbf{S}_2)^2$$

Exchange mechanisms: partially-filled orbitals.

Partially-filled d-orbitals can be obtained when an oxide is doped to make it 'mixed valence' e.g. $(\text{La}_{1-x}\text{Sr}_x)\text{MnO}_3$ or when the d-band overlaps with another band at the Fermi energy. Such materials are usually metals.

– Direct exchange

This is the main interaction in metals

Electron delocalization in bands that are half-full, nearly empty or nearly full.

Exchange depends critically on band filling.

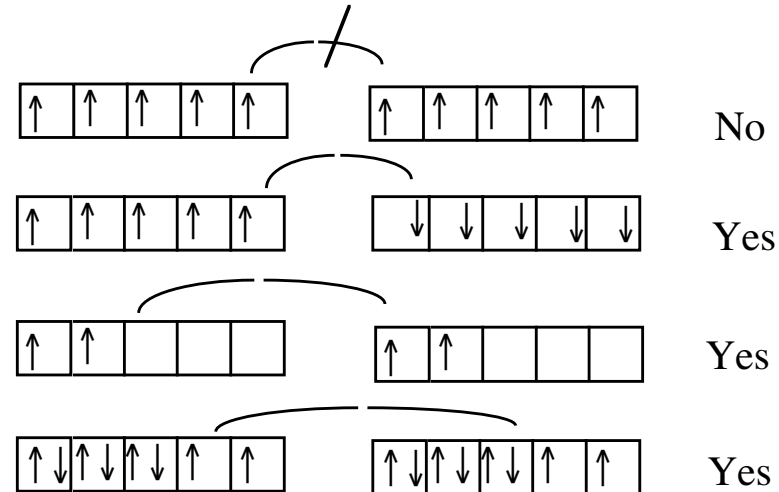

$$\mathcal{H}_{\text{ferro}} = \begin{bmatrix} \pm V & t \\ t & \pm V \end{bmatrix}$$

$$\mathcal{H}_{\text{AF}} = \begin{bmatrix} \pm V & t \\ t & -\pm V \end{bmatrix}$$

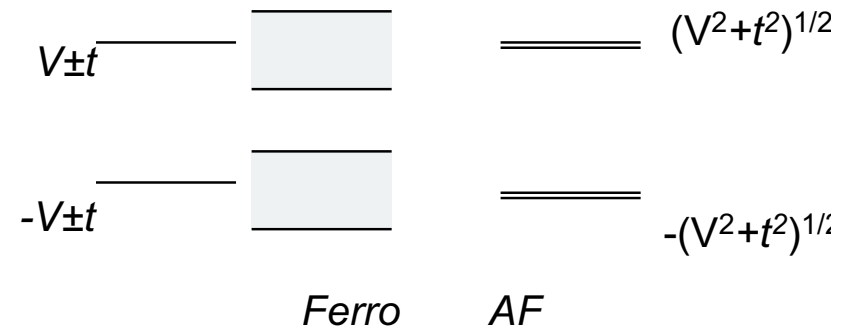

V is the local exchange potential, t is the transfer integral

– Double exchange

Electron transfer from one site to the next in partially (not half) filled orbitals is inhibited by noncollinearity of the core spins. The effective transfer integral for the extra electron is t_{eff} obtained by projecting the wavefunction onto the new z-axis.

$$t_{\text{eff}} = t \cos(\theta/2)$$

Double exchange in an antiferromagnetically ordered lattice can lead to spin canting.

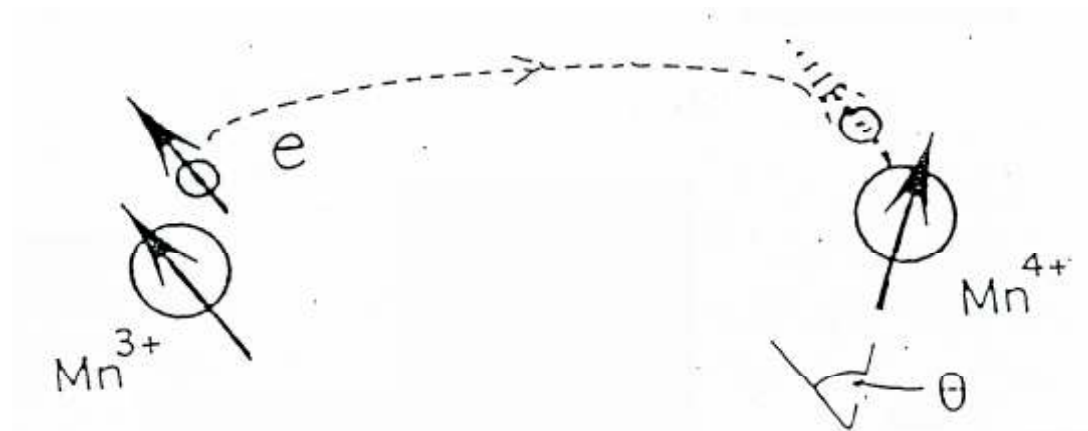
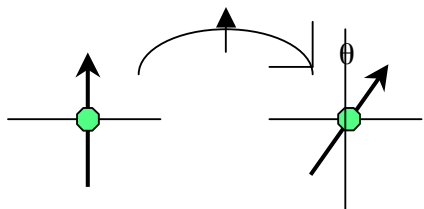

Double exchange between Mn^{3+} ($3d^4$) and Mn^{4+} ($3d^3$)

– Exchange via a spin-polarized valence or conduction band. **RKKY Interaction**

As in double exchange, there are localized core d-spins \mathbf{S} which interact via a delocalized electron \mathbf{s} in a partly-filled band. These electrons are now in a spin-polarized conduction band (s electrons)

$$\mathcal{H} = -\mathcal{J}_{sd}\Omega |\psi|^2 \mathbf{S} \cdot \mathbf{s}$$

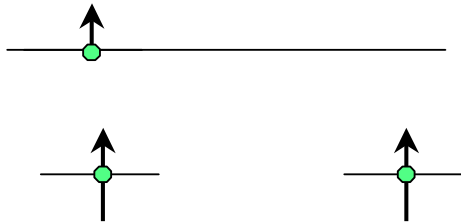

RKKY interaction In 4f metals, the localized moments in the 4f shell interact via electrons in the 5d/6s conduction band. The on-site interaction between a core spin S and a conduction electron spin s is $-\mathcal{J}_{sf}\mathbf{S} \cdot \mathbf{s}$, as in the $s-d$ model, where $\mathcal{J}_{sf} \approx 0.2$ eV. A single magnetic impurity creates an oscillating spin polarization in the conduction band which falls off as r^{-3} . For free electrons, this polarization varies as

$$F(\xi) = (\sin\xi - \xi\cos\xi)/\xi^4$$

where $\xi = 2k_F r$, k_F being the Fermi wave vector (Fig 5.12). This oscillating spin polarization results from the different potential seen by the \uparrow and \downarrow conduction electrons at the local moment. The first zero of $F(\xi)$ is at $\xi = 4.5$. The effective coupling between two localized spins is

$$\mathcal{J}_{eff} \approx -\frac{\mathcal{J}_{sf}^2 m^* k_F^2 V F(\xi)}{64\hbar^2} \quad (5.25)$$

where m^* is the effective mass of the conduction electrons and V is the unit cell volume. Since the Fermi wavevector is of order 0.1 nm, the sign of \mathcal{J}_{eff} fluctuates on a scale of nanometers. When only ferromagnetic nearest-neighbour coupling is important, the Curie temperature can be deduced from (5.18).

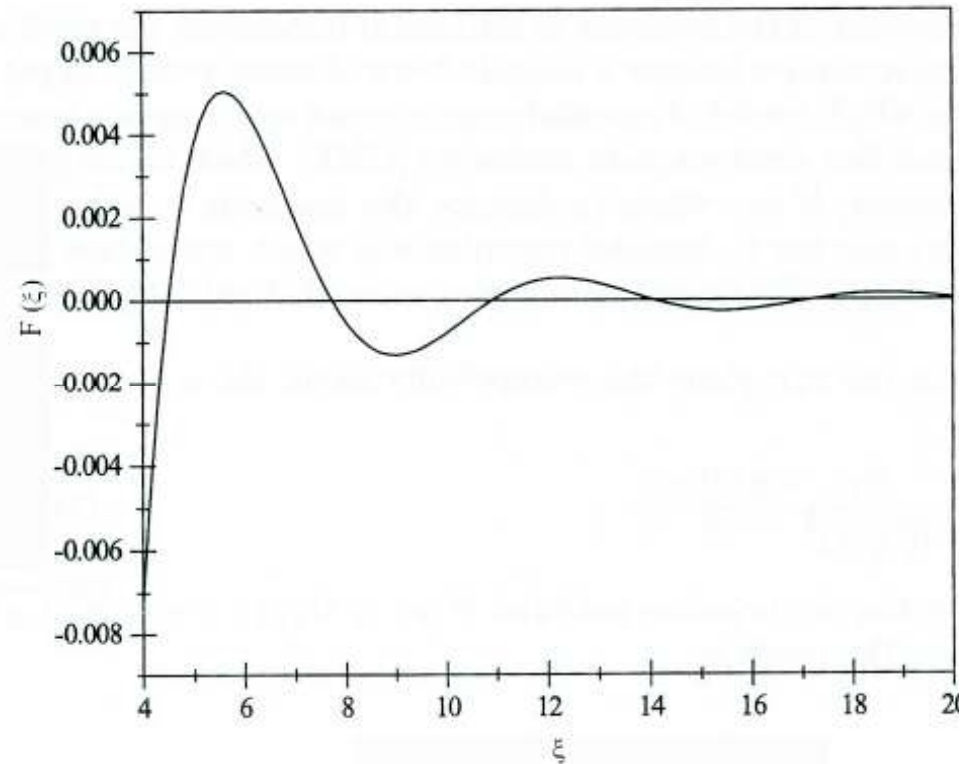

3. Band Magnetism

First consider whether a single magnetic impurity can keep its moment when dilute in a metal; e.g. Co in Cu

Anderson Model: A single impurity with a singly occupied orbital.

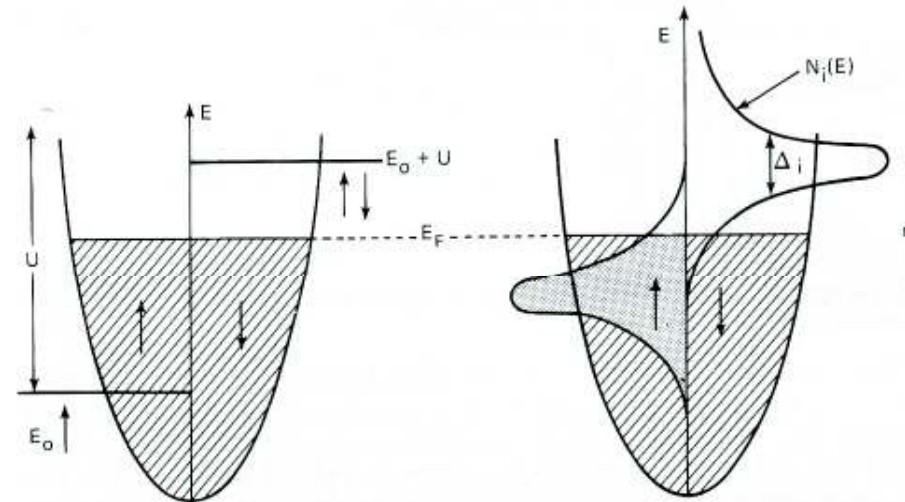

No hybridization

Hybridization

The number of unpaired impurity electrons $N = N^\uparrow - N^\downarrow$ is

$$N = \nu(E_F + \frac{1}{2}NU) - \nu(E_F - \frac{1}{2}NU)$$

where $\nu(E)$ is the integral of the impurity density of states $(E) = \int_0^E \mathcal{D}_i(E')dE'$. Expanding expression as a power series for small N , we find $N = NU\mathcal{D}_i(E_F) + (\frac{1}{24})(NU)^3\mathcal{D}_i''(E_F)$ where the second derivative $\mathcal{D}_i''(E) = d^2\mathcal{D}_i(E)/dE^2$ is negative. Hence $N^2 = [-24(1 - U\mathcal{D}_i(E_F)/\mathcal{D}_i''(E_F)U^3)]$. A moment will form spontaneously at the impurity provided

$1 - U\mathcal{D}_i(E_F) > 0$; since $\Delta_i \mathcal{D}_i(E_F) = 1$ we have the Anderson condition $U > \Delta_i$ for a magnetic impurity

Jaccarino-Walker model.

The existence presence or absence of a magnetic moment depends on the nearest neighbourhood.

e.g. $\text{Mo}_x\text{Nb}_{1-x}$ alloys.

Fe carries a moment in Mo and but no moment in Nb.

Fe in $\text{Mo}_x\text{Nb}_{1-x}$ alloys has a moment when there are seven or more Mo neighbours.

There is a distribution of nearest-neighbour environments. When $x \approx 0.6$, magnetic and nonmagnetic iron impurities coexist.

The s-d model.

$$\mathcal{H} = \sum_{i,j} t_{ij} c_i^\dagger c_j - \sum_{k,l} \mathcal{J}_{sd} \mathbf{S}_k \cdot \mathbf{s}_l$$

Conduction band

s - d exchange

$$W = 2Zt$$

When $J > 0$ (ferromagnetic exchange) a giant moment may form
e.g. Co in Pd, $m_{\text{Co}} \approx 20 \mu_B$

When $J < 0$ (antiferromagnetic exchange) a *Kondo* singlet may form

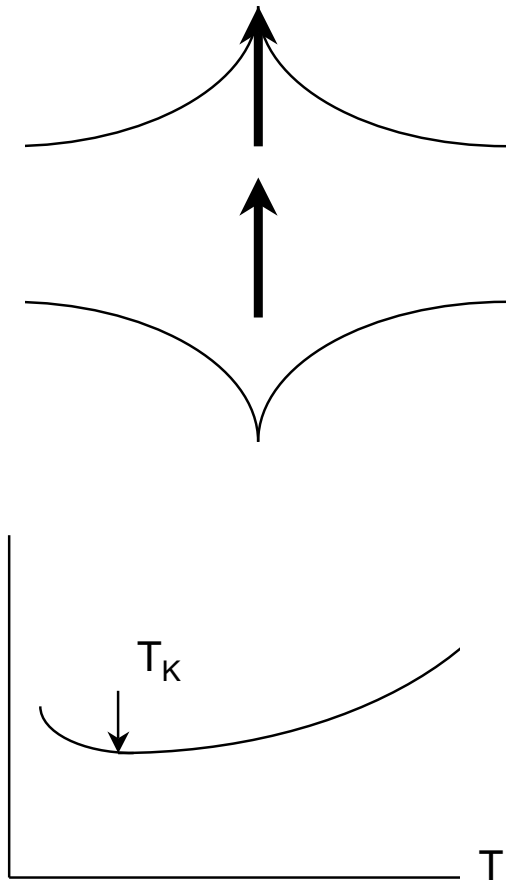
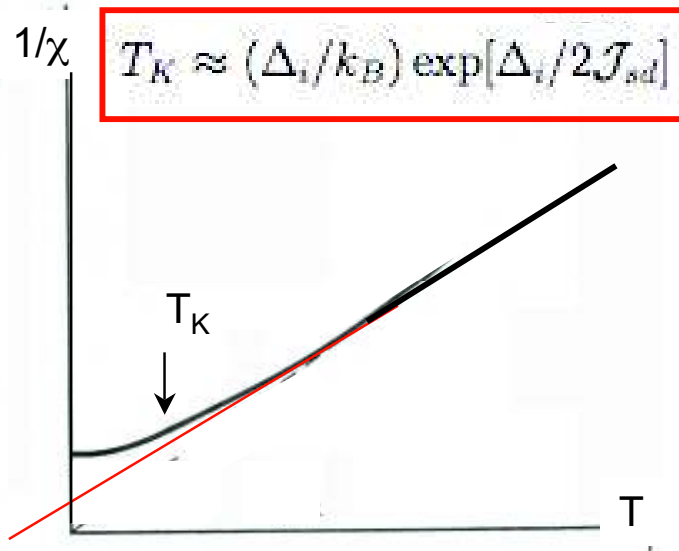
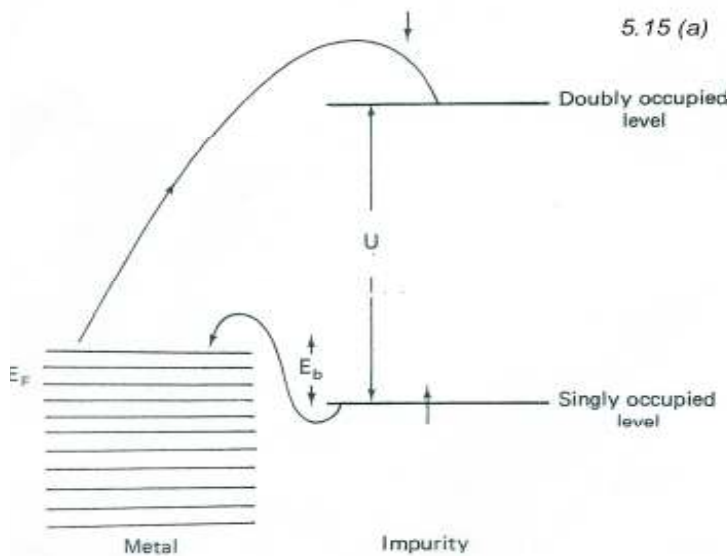

3.2 Ferromagnetic metals

Strong and weak ferromagnets

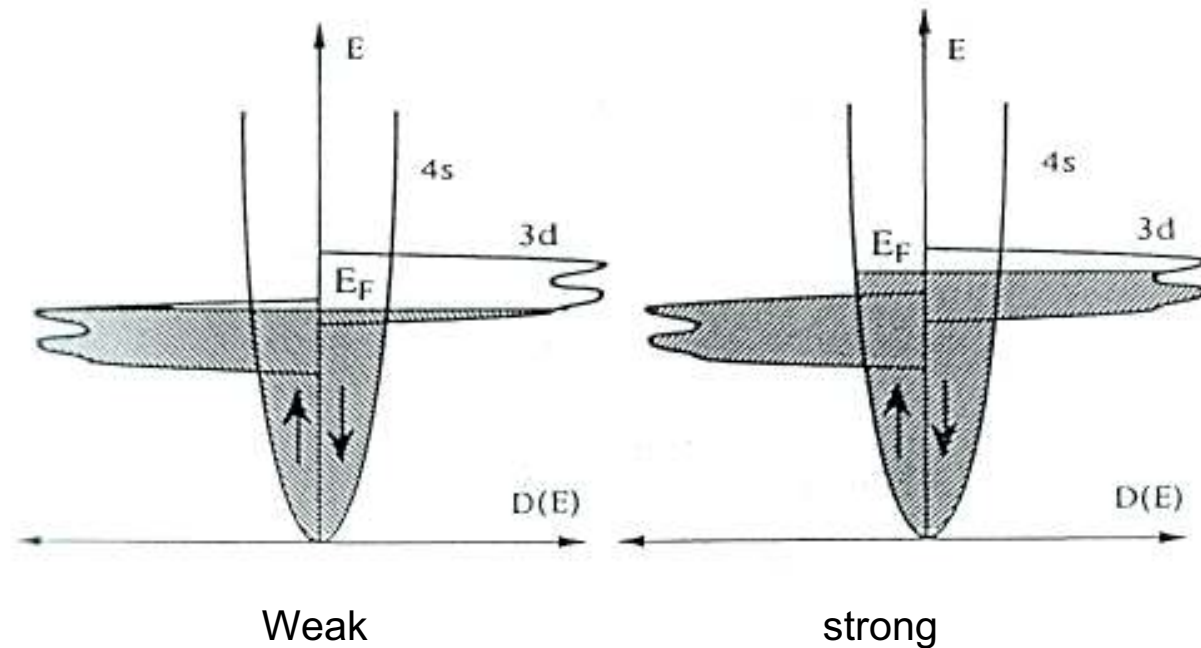

Strong ferromagnets like Co or Ni have all the states in the d -band filled (5 per atom).

Weak ferromagnets like Fe have both \uparrow and \downarrow d -electrons at the E_F .

Some metals have narrow bands and a large density of states at the Fermi level; This leads to a large Pauli susceptibility $\chi_{\text{Pauli}} \approx 2\mu_0 N(E_F)\mu_B^2$.

When χ_{Pauli} is large enough, it is possible for the band to split *spontaneously*, and ferromagnetism appears.

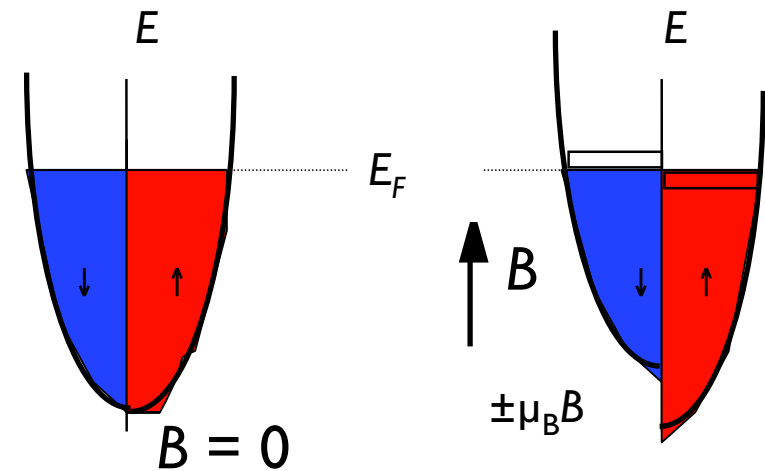
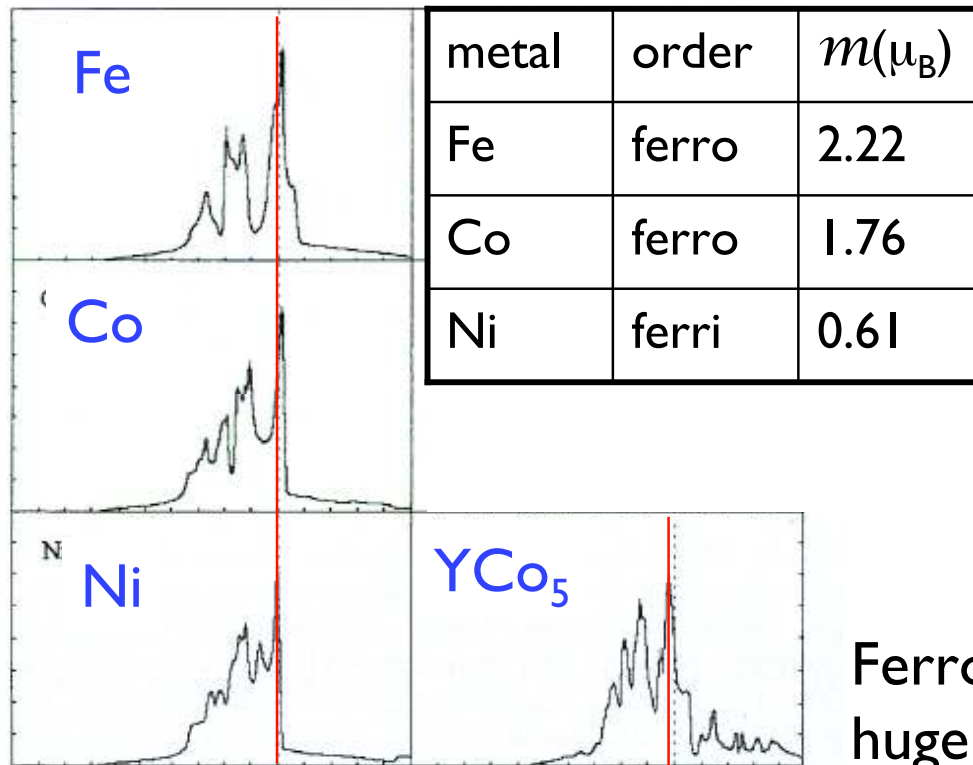

$$M = (N^\uparrow - N^\downarrow)\mu_B$$

$$N^{\uparrow,\downarrow} = \int_{E_0}^{E_F} N^{\uparrow,\downarrow}(E)dE$$

Ferromagnetic metals and alloys all have a huge peak in the density of states at E_F

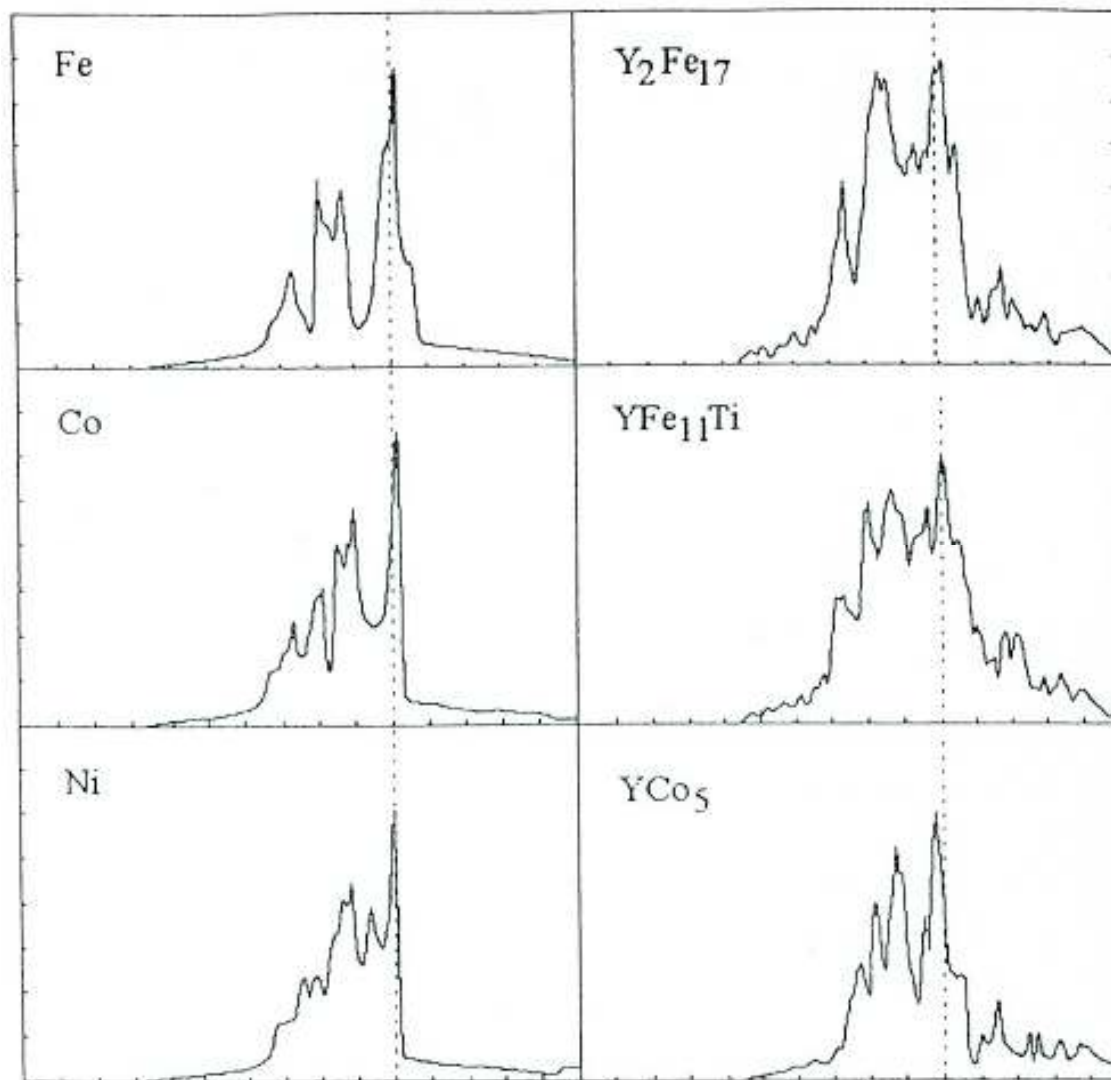

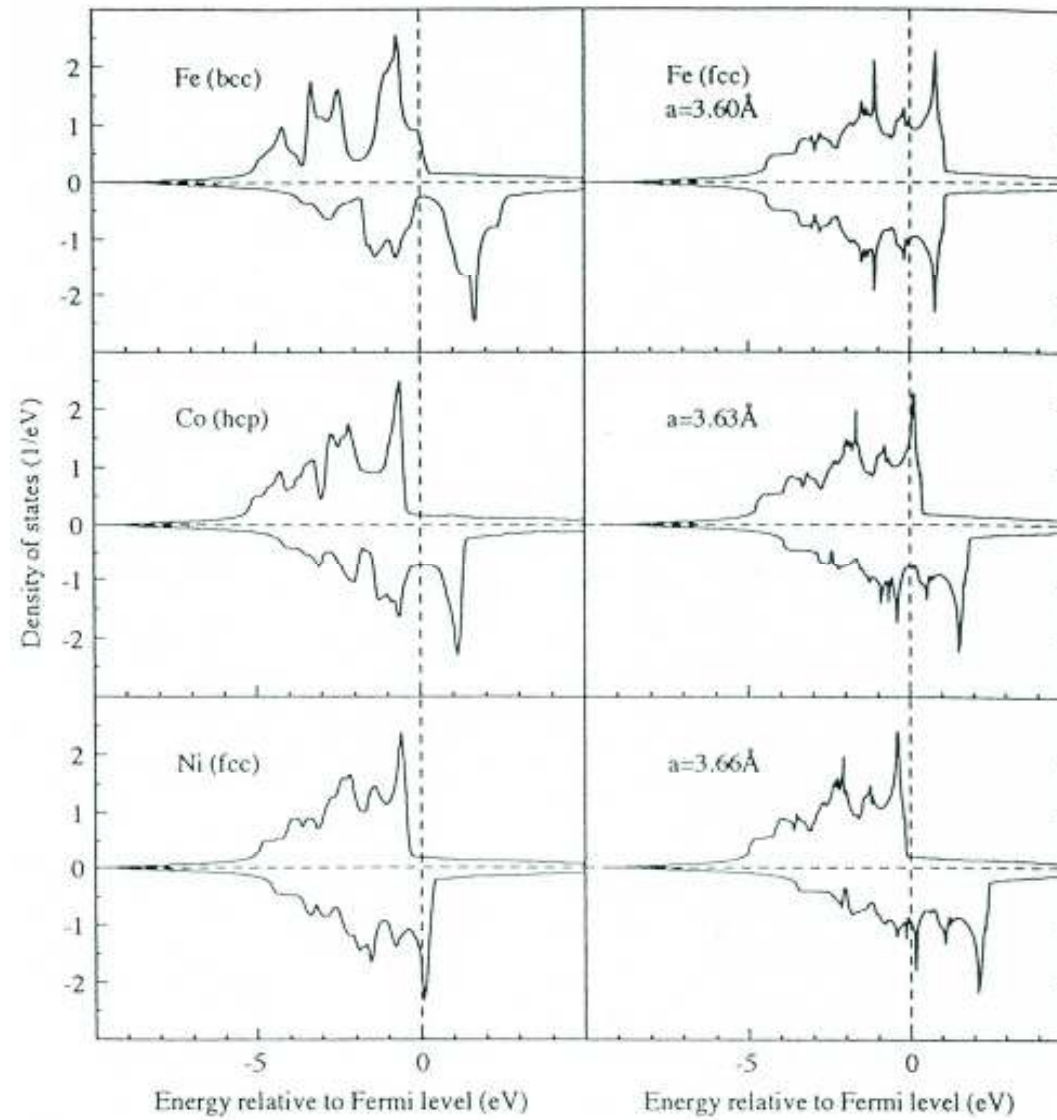

The Stoner model predicts an unrealistically high Curie temperature. The Stoner criterion is unsatisfied if

$$n_V \chi_p < 1$$

$$\text{But } \chi_p = [3n\mu_0\mu_B^2/2k_B T_F][1 - \pi^2 T^2/12T_F^2]$$

Hence the Curie temperature should be of order the Fermi temperature, $\approx 10,000$ K ! and there should be no moment above T_C .

In fact, T_C in metals is much lower, and the moment persists above T_C , in a disordered form.

Only very weak itinerant ferromagnets resemble the Stoner model.

The effective paramagnetic moment $\gg m_0$.

	m_{eff}	m_0
Ni	1.0	0.6
ZrZn ₂	1.8	0.2
CrO ₂	2.4	2.0

The *rigid band model* envisages a fixed, spin-split density of states for the ferromagnetic 3d elements and their alloys.

Electrons are poured in.

Ignoring the spin polarization of the 4s band,

$$n_{3d} = n_{3d}^{\uparrow} + n_{3d}^{\downarrow}$$

$$m = (n_{3d}^{\uparrow} - n_{3d}^{\downarrow})\mu_B$$

For strong ferromagnets $n_{3d}^{\uparrow} = 5$.

hence $m = (10 - n_{3d}) \mu_B$

e.g. Ni $3d^{9.4}4s^{0.6}$ has a moment of $0.6 \mu_B$

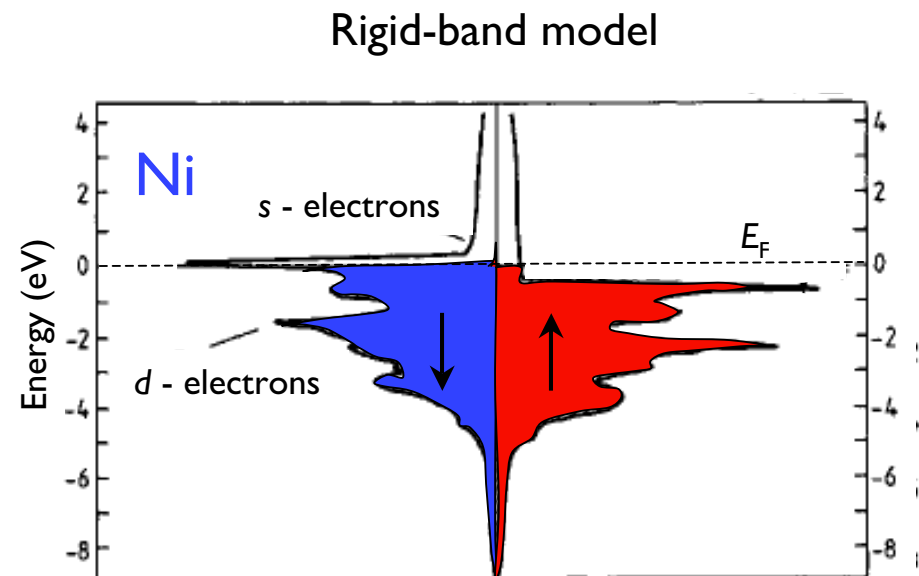

Intrinsic properties of the ferromagnetic 3d elements.

	T_C	ρ	σ_s	M_s	$J_s(RT)$	m	$Ds(E_F)$	I	K_1	g
	K	kg m ⁻³	A m ² kg ⁻¹	kA m ⁻¹	T	μ_B	1/eV	eV	J m ⁻³	
Fe	1044	7874	217	1710	2.16	2.22	1.54	0.93	48	2.09
Co	1390	8836	162	1431	1.76	1.75	1.72	0.99	410	2.17
Ni	628	8902	55.5	494	0.61	0.62	2.02	1.01	-5	2.19

3.3 Slater Pauling Curve

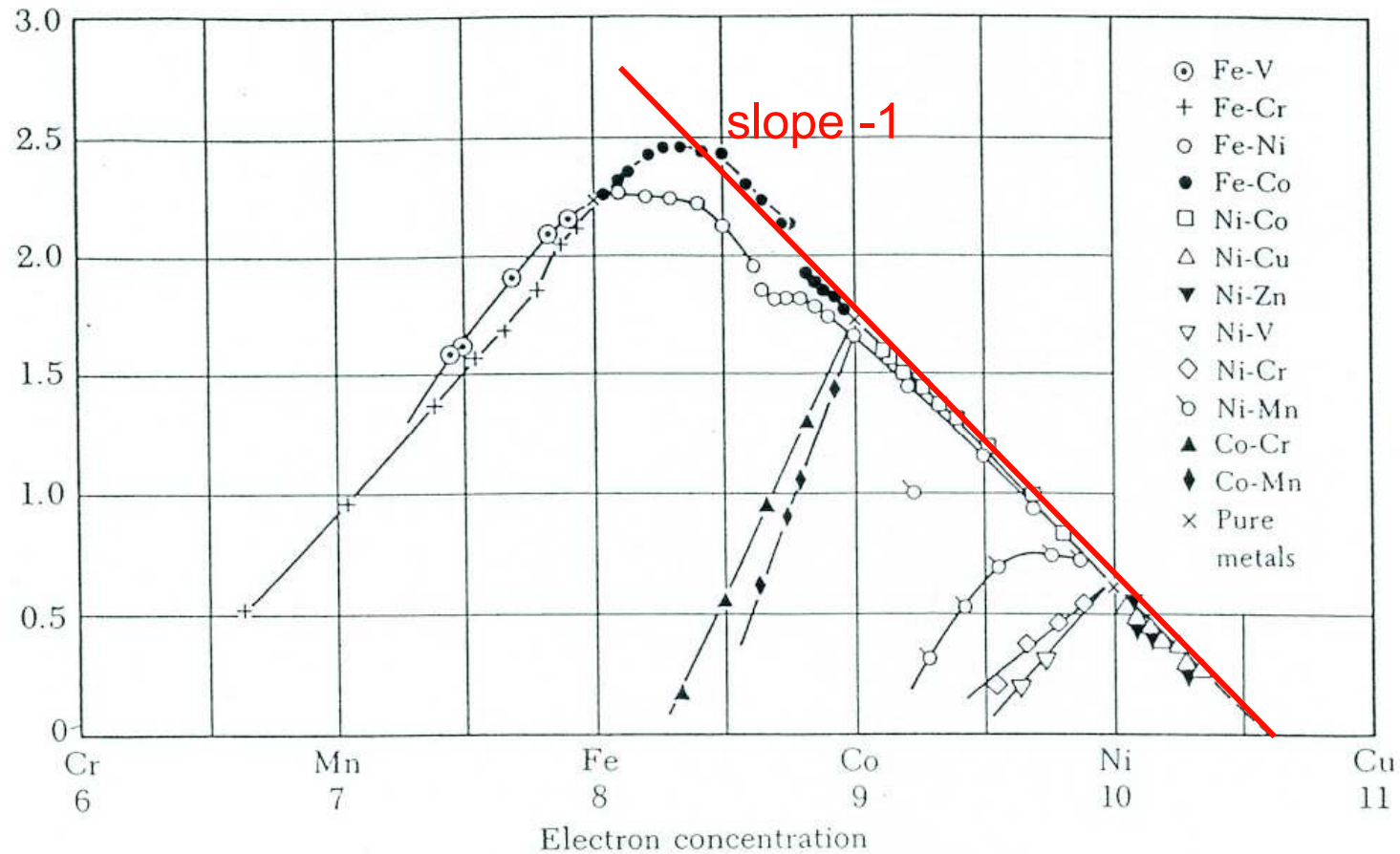

Moments of strong ferromagnets lie on the red line;

Moments of weak ferromagnets lie below it

3.4 Impurities in ferromagnets.

$$\Delta_i = \pi D(E_F) V_{kd}^2$$

A light 3d impurity in a ferromagnetic host
e.g. Ti in Co forms a *virtual bound state*.
The width $\Delta_i \approx 1$ eV.

The Ti ($3d^3 4s^1$) pours its 3d electrons into
the Co $3d\downarrow$ band.

Moment reduction per Ti is $3 + 1.6$.

Hybridization between impurity and host
leads to a small reverse moment on Ti,
i.e. antiferromagnetic coupling.

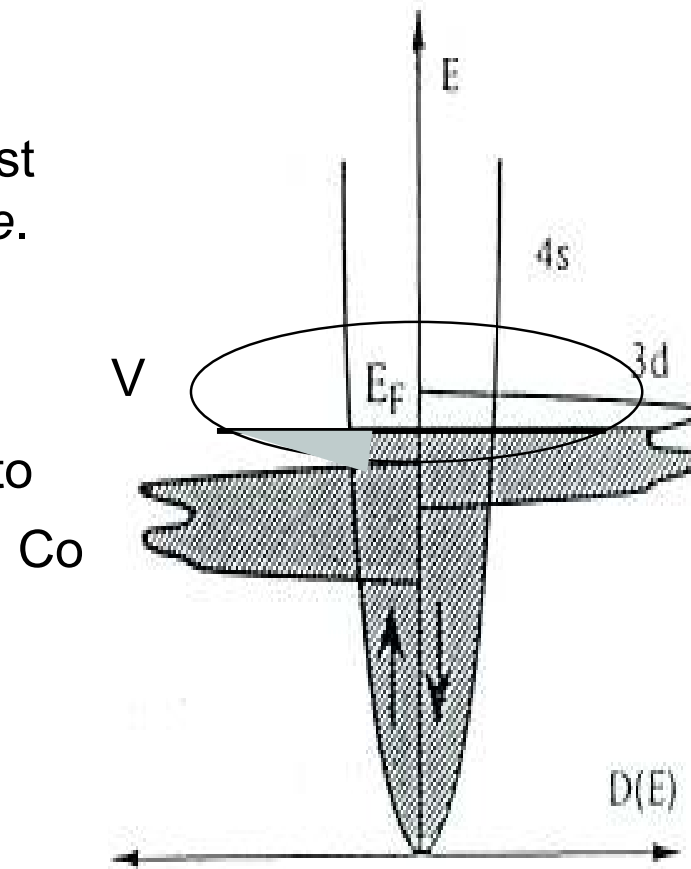

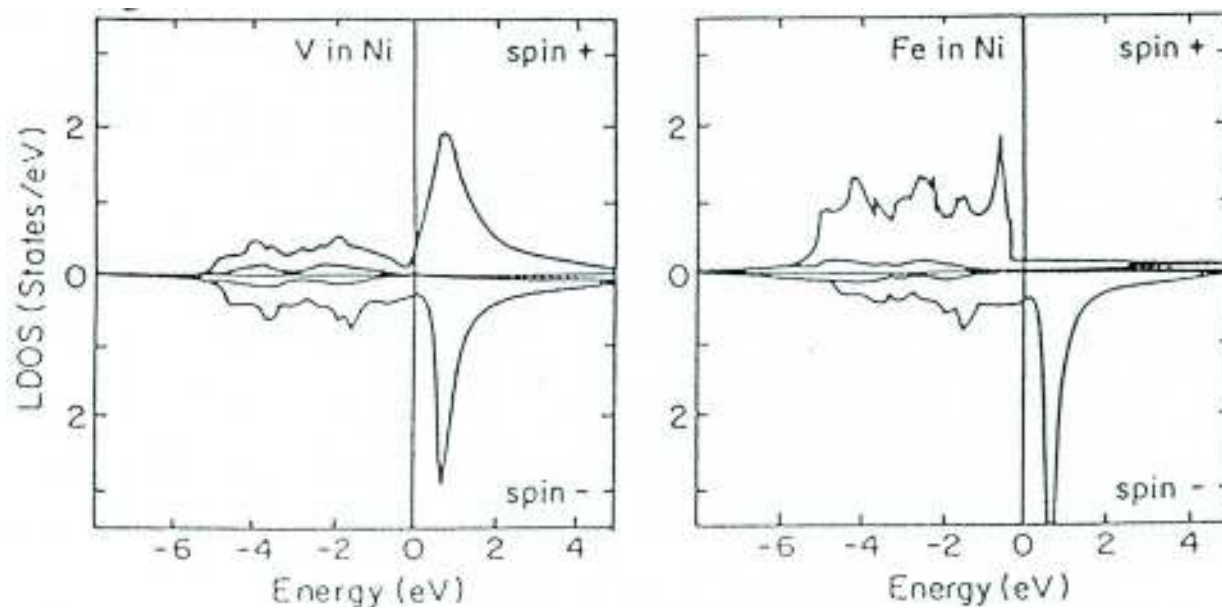

3.5 Half-metals.

- A magnetically-ordered metal with a fully spin-polarised conduction band
- $$P = (N_{\uparrow} - N_{\downarrow}) / (N_{\uparrow} + N_{\downarrow})$$
- Metallic for \uparrow electrons but semiconducting for \downarrow electrons. Spin gap Δ_{\uparrow} or Δ_{\downarrow}
- Integral spin moment $n \mu_B$
- Mostly oxides, Heusler alloys, some semiconductors

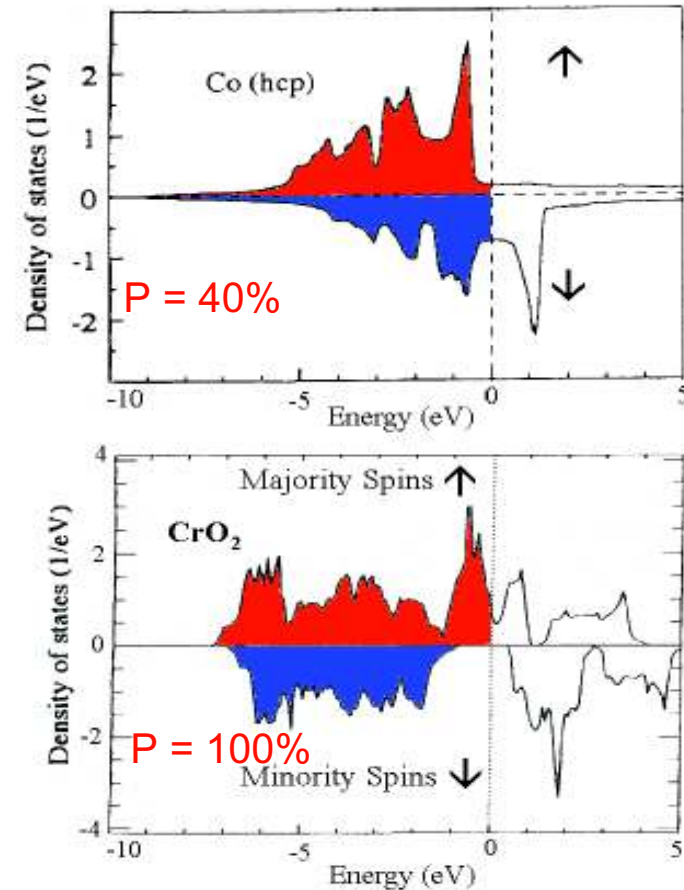

3.6 The two-electron model

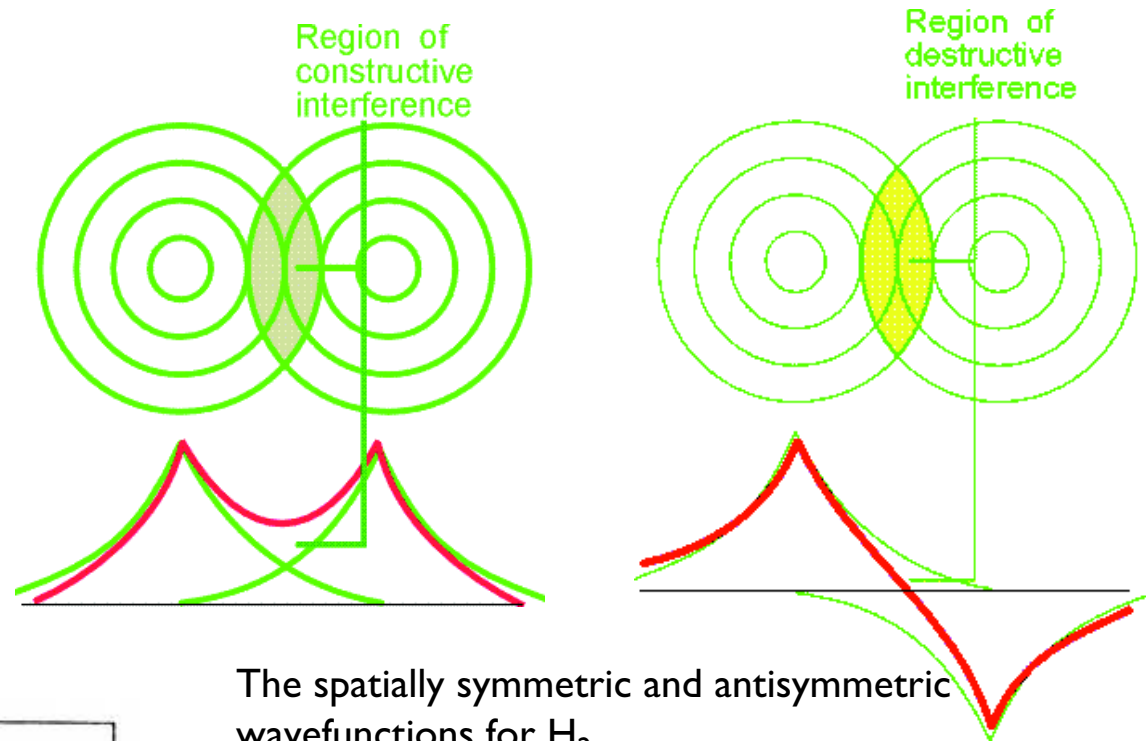

The spatially symmetric and antisymmetric wavefunctions for H₂.

$$\phi_s = (1/\sqrt{2})(\psi_1 + \psi_2); \quad \phi_a = (1/\sqrt{2})(\psi_1 - \psi_2)$$

Bloch-like functions

$$\phi_l = (1/\sqrt{2})(\phi_s + \phi_a); \quad \phi_r = (1/\sqrt{2})(\phi_s - \phi_a)$$

Wannier-like functions

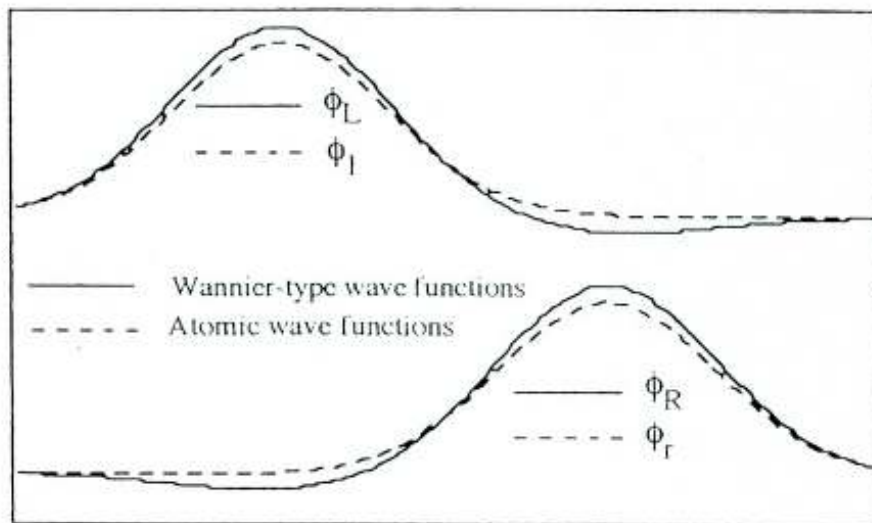

$$\Psi_1 = \phi_l(r)\phi_l(r'); \Psi_2 = \phi_l(r)\phi_r(r'); \Psi_3 = \phi_r(r)\phi_l(r'); \Psi_4 = \phi_r(r)\phi_r(r')$$

The functions Ψ_1 and Ψ_4 represent doubly-occupied states, The interaction matrix is

$$\begin{pmatrix} U & t & t & \mathcal{J}_d \\ t & 0 & \mathcal{J}_d & t \\ t & \mathcal{J}_d & 0 & t \\ \mathcal{J}_d & t & t & U \end{pmatrix} \quad (5.37)$$

The Coulomb interaction U is the energy penalty when two electrons are put into the same orbit. It is several electron volts

$$U = \int \phi_l^*(r)\phi_l^*(r')\mathcal{H}(r,r')\phi_l(r)\phi_l(r')drdr'$$

The transfer or hopping integral t is also positive, and is $\lesssim 1$ eV. It represents the bandwidth. More generally, in the tight-binding approximation, the bandwidth is $2Z_n t$, where Z_n is the number of nearest-neighbours.

$$t \approx \int \phi_l^*(r)\phi_l^*(r')\mathcal{H}(r,r')\phi_l(r)\phi_r(r')drdr'$$

The direct exchange between doubly-occupied sites is smaller, and of order 0.1eV

$$\mathcal{J}_d = \int \phi_l^*(r)\phi_l^*(r')\mathcal{H}(r,r')\phi_r(r)\phi_r(r')drdr'$$

The interaction matrix (5.34) can be diagonalized directly. Two eigenvalues are of order U , and are therefore irrelevant. The other states are a delocalised ferromagnetic state (the spatial part of the wavefunction is antisymmetric) with eigenvalue $E_{FM} = \mathcal{J}_d$

$$\Psi_{FM} = (1/\sqrt{2})[\phi_l(r)\phi_r(r') - \phi_r(r)\phi_l(r')]$$

and an antiferromagnetic state (the spatial part of the wave function is symmetric)

$$\Psi_{AF} = (\sin \chi/\sqrt{2})[\phi_l(r)\phi_l(r') + \phi_r(r)\phi_r(r')] + (\cos \chi/\sqrt{2})[\phi_l(r)\phi_r(r') + \phi_r(r)\phi_l(r')]$$

where $\tan \chi = 4t/U$. The associated energy is $E_{AF} = U/2 + J_d - (4t^2 + U^2/4)^{1/2}$.

The effective exchange is $\mathcal{J}_{eff} = \frac{1}{2}(E_{AF} - E_{FM})$

$$\mathcal{J}_{eff} = J_d + U/4 - \sqrt{(t^2 + U^2/16)} \quad (5.38)$$

$\mathcal{J}_{eff} > 0$ indicates ferromagnetism. The direct exchange favours ferromagnetism, but strong interatomic hopping t favours antiferromagnetism. When $U \gg t$, and $\mathcal{J}_d = 0$, the kinetic exchange is antiferromagnetic:

$$\mathcal{J}_{eff} = -2t^2/U \quad (5.39)$$

Hubbard model

A famous Hamiltonian for an array of $1s^1$ atoms is

Rotate Image Right

$$\mathcal{H} = \sum_{i,j} t c_i^\dagger c_j + U \sum_i J_{sd} n_{i\uparrow} n_{i\downarrow}$$

The first term is the transfer term that creates the band of width $W = 2Z_n t$, the second is the Coulomb energy penalty involved in placing two electrons on the same atom.

Electrons are localised when $U/2Z_n t > 1$. When this condition is satisfied we have a *Mott-Hubbard insulator*.

The first term can be written

$$U[(n^\uparrow + n^\downarrow)^2/4 - (n^\uparrow - n^\downarrow)^2/4]$$

The Stoner interaction $-(I/4)(n^\uparrow - n^\downarrow)^2$ is identified as the spin-dependent part of the on-site Coulomb interaction, hence $I = U/4$.

3.6 Electronic structure calculations

4. Collective excitations

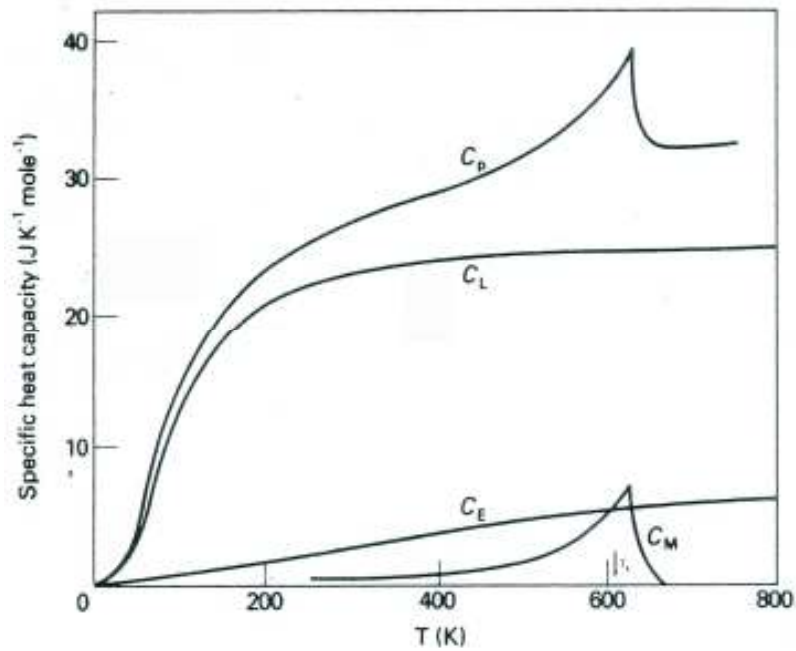

Heat capacity of Ni

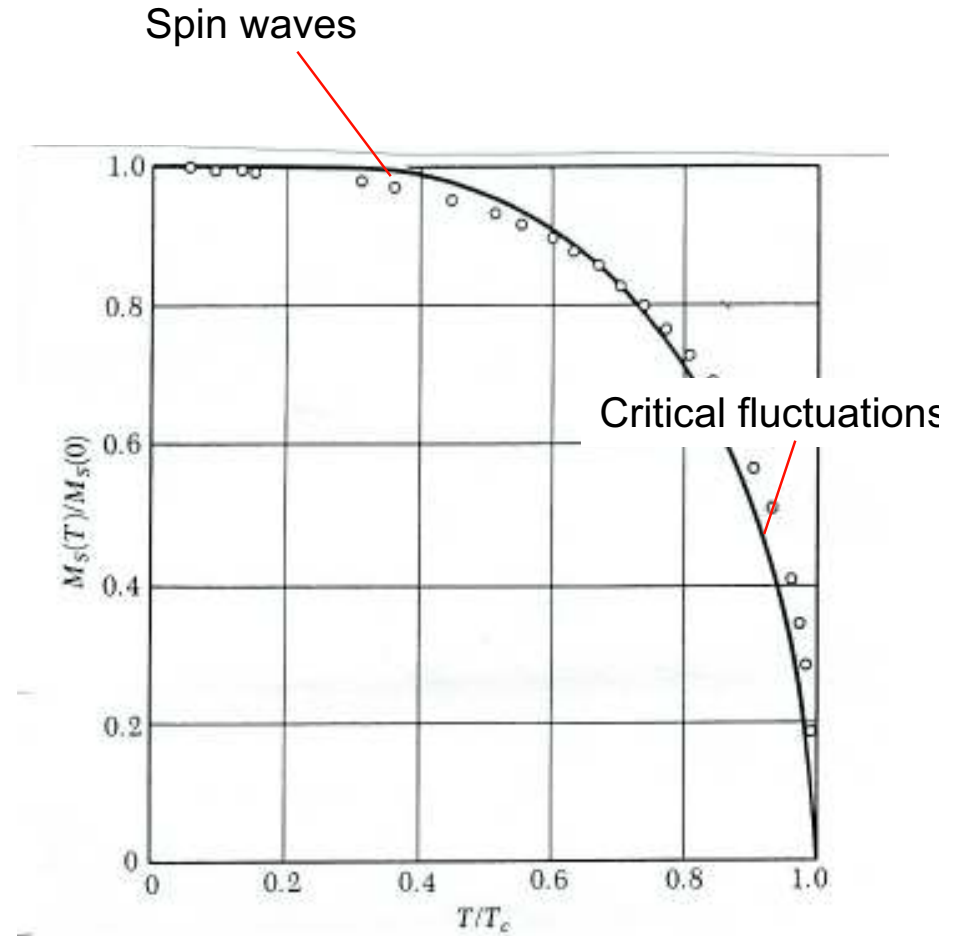

Reduced magnetization of Ni

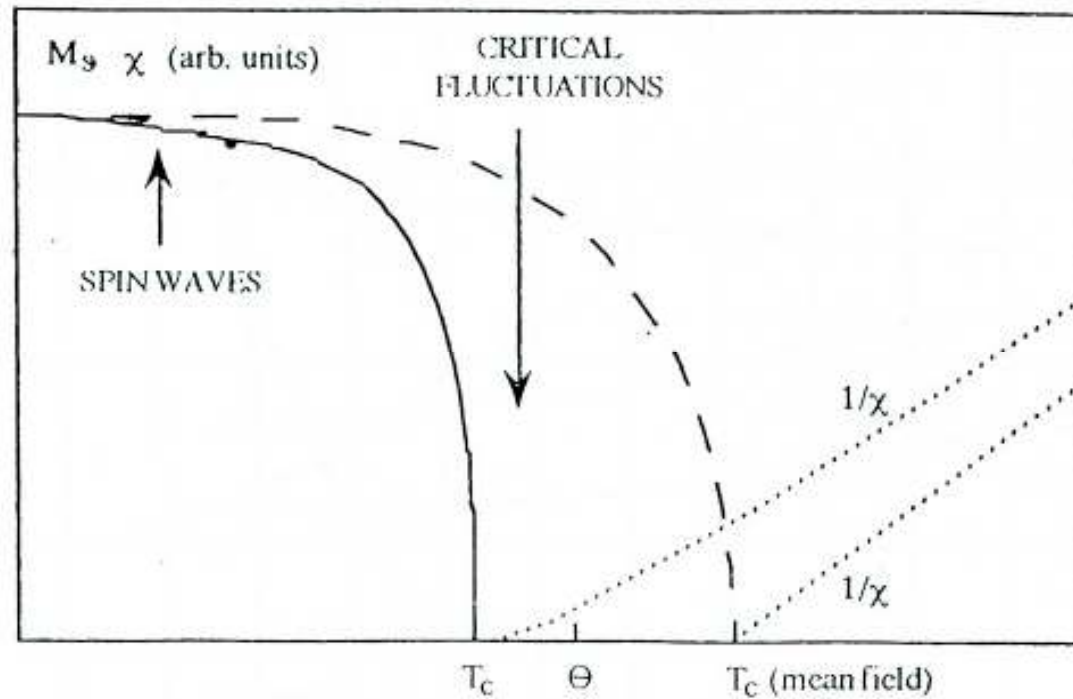

The Curie point can be calculated from the exchange constants derived from spin-wave dispersion relations. It is about 40% greater than the measured value.

Also, above T_c $\chi \approx (T - T_c)^{-1.3}$.

5.4 Spin waves

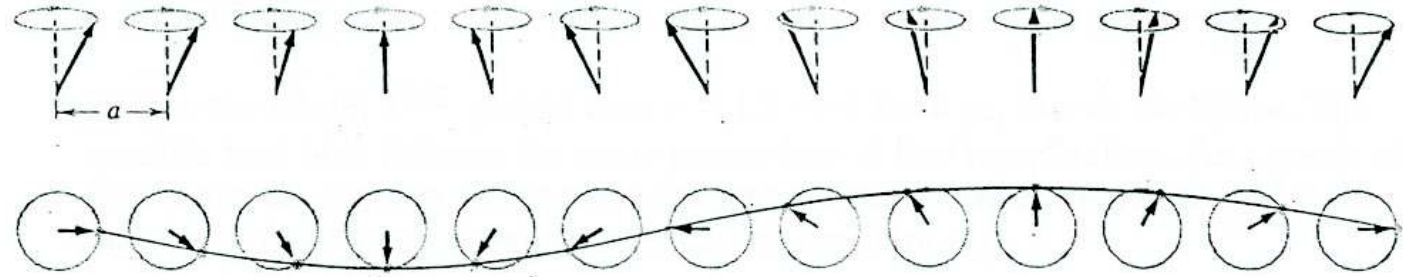

$$q = 2\pi/\lambda$$

$$E = \hbar\omega_q / 2\pi$$

$$\hbar \frac{d\mathbf{S}_i}{dt} = \mu_0 g \mu_B \mathbf{S}_i \times \mathbf{H}^i$$

\mathbf{H}^i is the molecular field at site i due to the neighbours at sites $i \pm 1$. From (5.25), $\mathbf{H}^i = 2\mathcal{J}(\mathbf{S}_{i-1} + \mathbf{S}_{i+1})/\mu_0 g \mu_B$, hence $\hbar d\mathbf{S}_i/dt = 2\mathcal{J}\mathbf{S}_i \times (\mathbf{S}_{i-1} + \mathbf{S}_{i+1})$. This can be written in cartesian coordinates:

$$\hbar \frac{dS_i^x}{dt} = 2\mathcal{J} [S_i^y (S_{i-1}^z + S_{i+1}^z) - S_i^z (S_{i-1}^y + S_{i+1}^y)]$$

and cyclic permutations. For small deviations, we can approximate $S_i^z = S$, and neglect terms like $S_i^x S_j^y$. Hence

$$\begin{aligned} \hbar \frac{dS_i^x}{dt} &= 2\mathcal{J}S [2S_i^y - S_{i-1}^y - S_{i+1}^y] \\ \hbar \frac{dS_i^y}{dt} &= 2\mathcal{J}S [2S_i^x - S_{i-1}^x - S_{i+1}^x] \\ \hbar \frac{dS_i^z}{dt} &= 0 \end{aligned} \tag{5.41}$$

Solutions are of the form $S_i^x = u \exp i(pqa - \omega t)$, $S_i^y = vS \exp i(pqa - \omega t)$, where p is an integer and a is the interatomic spacing. Substituting these back into (5.41) gives $-i\hbar\omega u = 4\mathcal{J}S(1 - \cos qa)v$, $-i\hbar\omega v = 4\mathcal{J}S(1 - \cos qa)u$. Hence the result for a one-dimensional chain of isotropic spins, plotted in Fig 5.15,

$$\hbar\omega_q = 4\mathcal{J}S(1 - \cos qa) \quad (5.42)$$

In the limit of small wave vectors, the spin wave dispersion relation becomes

$$\mathcal{E}_q \approx D_{sw}q^2 \quad (5.43)$$

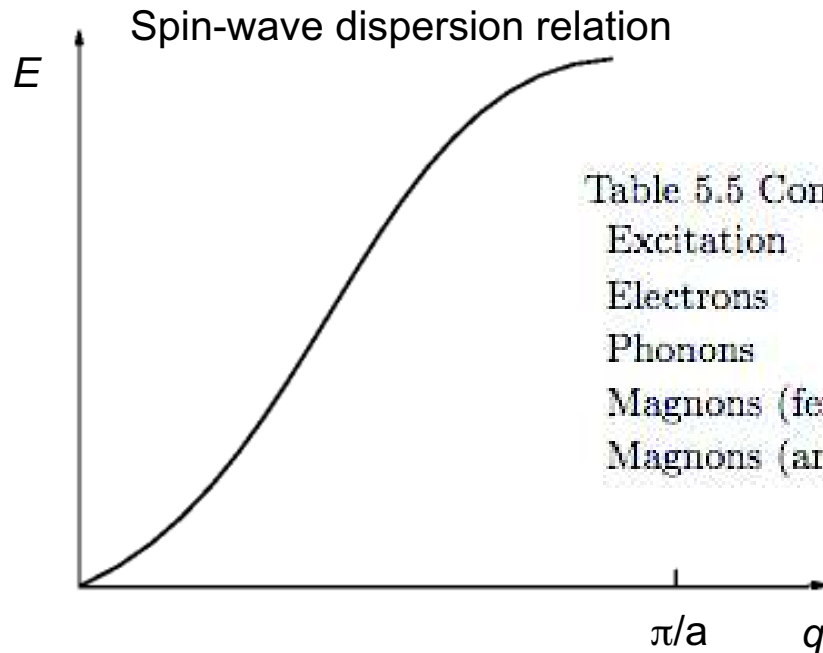

Table 5.5 Comparison of excitations in solids.

Excitation		Dispersion	Specific Heat
Electrons	fermions	$E_k \approx (\hbar/2m)k^2$	γT
Phonons	bosons	$E_q \approx c_0 q$	T^3
Magnons (ferromagnetic)	bosons	$E_q \approx D_{sw}q^2$	$T^{3/2}$
Magnons (antiferromagnetic)	bosons	$E_q \approx D_{af}q$	T^3

Equation (5.421) can be derived quantum mechanically from the Heisenberg hamiltonian (5.24) where the sum is over nearest-neighbour pairs i, j . The hamiltonian

$$\mathbf{S}_i \cdot \mathbf{S}_j = S_i^z S_j^z + S_i^+ S_j^- + S_i^- S_j^+ \quad (5.44)$$

can be written in terms of the raising and lowering operators.

The ground-state of the system $|\Phi\rangle$ has all the spins aligned in the z -direction, so that $\mathcal{H}|\Phi\rangle = NS^2|\Phi\rangle$. Flipping a spin $\frac{1}{2}$ at site i using S_i^- reduces M_S^z from S to $S-1$. $|i\rangle = S_i^-|\Phi\rangle$ lowers the total spin of the system by $2S$. However, $|i\rangle$ is not an eigenstate of the Hamiltonian of the chain of spins with nearest-neighbour interactions

$$\mathcal{H} = -2\mathcal{J} \sum_i \left[S_i^z S_{i+1}^z + \frac{1}{2}(S_i^+ S_{i+1}^- + S_i^- S_{i+1}^+) \right]$$

because $\mathcal{H}|i\rangle = 2\mathcal{J}[-NS^2 + 2S|i\rangle - S|i+1\rangle - S|i-1\rangle]$. It is necessary to form linear combinations like

$$|q\rangle = \frac{1}{\sqrt{N}} \sum_i e^{iq \cdot r_i} |i\rangle \quad (5.46)$$

This state is a magnon, a spin flip delocalised on the chain, with wave-vector q . Then

$$\begin{aligned} \mathcal{H} |q\rangle &= \frac{2\mathcal{J}}{\sqrt{N}} \sum_i e^{iq \cdot r_i} [-NS^2 + 2S|i\rangle - S|i+1\rangle - S|i-1\rangle] \\ &= [-2\mathcal{J}NS^2 + 4\mathcal{J}S(1 - \cos qa)] |q\rangle \end{aligned} \quad (5.47)$$

Dropping the first, constant term, we have $E(q) = 4\mathcal{J}S(1 - \cos qa)$, as before (5.42).

Bloch $T^{3/2}$ law

The average number of quantized spin waves in a mode q is given by the Bose distribution $\langle n_q \rangle = 1/[\exp(\hbar\omega_q/k_B T) - 1]$ because magnons behave like bosons; each magnon corresponds to the reversal of one spin $\frac{1}{2}$ over the whole sample, or a change $\Delta M_S = 1$ for the whole system. However, the magnon density of states $N(\omega) \propto \omega^{\frac{1}{2}}$, just as for electrons which have a similar dispersion relation $\mathcal{E}_k = \hbar^2 k^2/2m$. It follows that

$$\Delta M/M(0) = (0.0587/S\nu)(k_B T/2S\mathcal{J})^{3/2} \quad (5.48)$$

This is the *Bloch $T^{3/2}$ power law*. The integer $\nu = 1, 2$ or 4 for a simple cubic, body-centred cubic or face-centred cubic lattice. Specific heat follows the same power law

Anisotropy introduces a spin-wave gap at $q = 0$. It is K_1/n

e.g. Cobalt: $n = 9 \cdot 10^{28} \text{ m}^{-3}$, $K_1 = 500 \text{ kJ m}^{-3}$, $D_{\text{sw}} = 8 \text{ J m}^{-2}$, $\Delta_{\text{sw}} = 0.4 \text{ K}$

4.2 Stoner excitations

Electrons at the Fermi level are excited from a state k into a state $k-q$

$$\hbar\omega_q = E_k - E_{k-q} + \Delta_{ex}$$

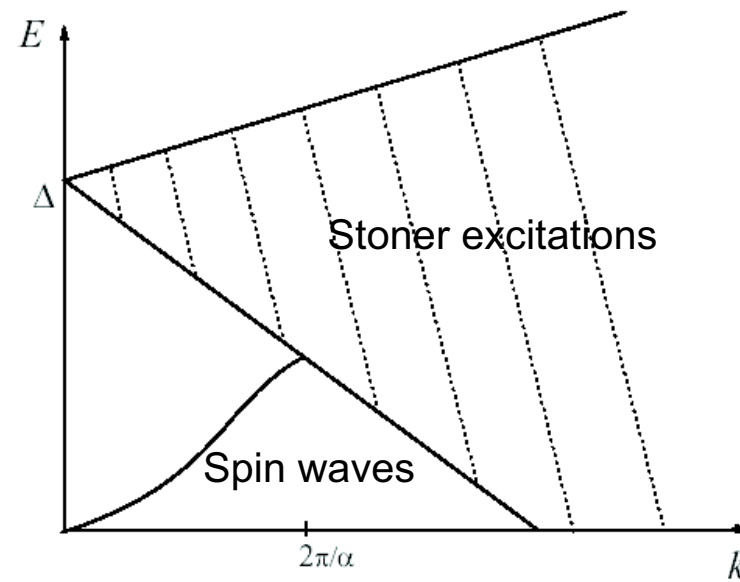
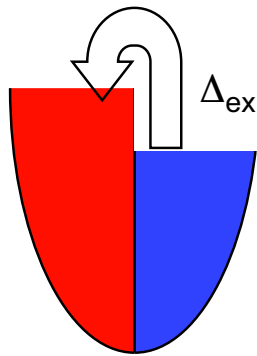

4.3 Mermin-Wagner theorem

Ferromagnetic order is impossible in one or two dimensions !

The number of magnons excited is:

$$n_m = \int_0^{\infty} \frac{N(\omega) d\omega}{e^{\hbar\omega/kT} - 1}$$

Where $N(\omega)$ is the density of states:

Set $x = \hbar\omega/kT$

In 3D $(k_B T / \hbar)^{3/2} \int_0^{\infty} x^{1/2} dx / (e^x - 1)$

3D: $N(\omega) \approx \omega^{1/2}$

2D: $N(\omega) \approx \text{cst}$

1D: $N(\omega) \approx \omega^{-1/2}$

This is the Bloch $T^{3/2}$ law

But in 2D and 1D, the integral diverges because the lower limit is zero!

Magnetic order is possible in the 3D Heisenberg model, but not in lower dimensions. This divergence can be overcome if there is some anisotropy which creates a gap in the spin-wave spectrum at $q = 0$. Two-dimensional ferromagnetic layers do exist

4.4 Critical behaviour

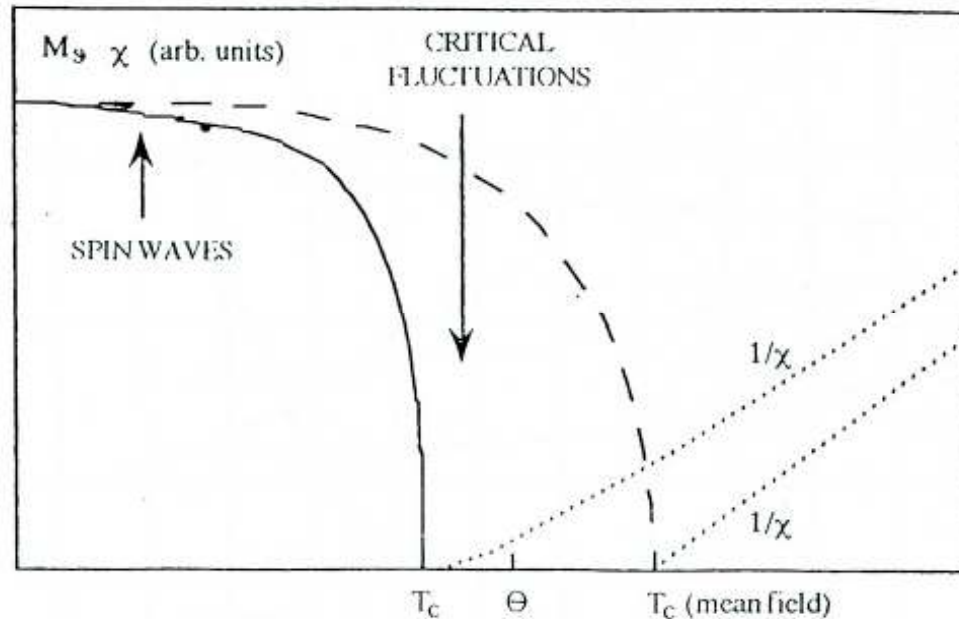

There is a large discrepancy between T_C calculated from the exchange constants J , deduced from spin-wave dispersion relations and the measured value.

$$G(r_{ij}) = \langle \mathbf{S}_i \cdot \mathbf{S}_j \rangle - \langle \mathbf{S}_i \rangle \cdot \langle \mathbf{S}_j \rangle$$

$$G(r) \sim \exp(-r/\xi)$$

ξ Is the correlation length

Table 5. 6 More critical exponents for a mean-field ferromagnet

Correlation length $\xi \approx |T - T_C|^{-\nu}$ $\nu = \frac{1}{2}$

Correlations at T_C $G(r) \approx |r|^{-(1+\eta)}$ $\eta = 0$



5. Anisotropy

Leading term:

$$E_a = K_u \sin^2 \theta$$

Three sources:

- Shape anisotropy, due to H_d
- Magnetocrystalline anisotropy
- Induced anisotropy, due to stress or field annealing

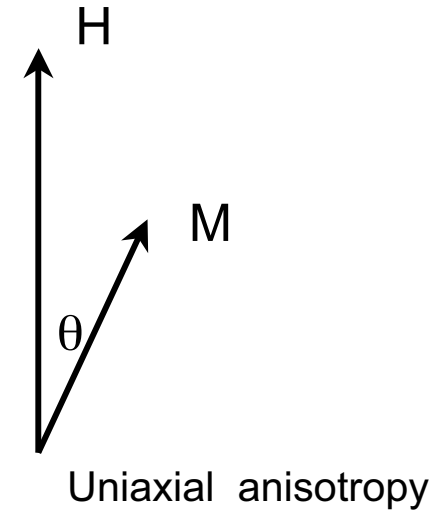

5.1. Shape anisotropy

Demag. factor

$$U_m = (1/2)NV\mu_0M^2$$

Difference in energy between easy and hard axes is ΔU .

$$N + 2N' = 1$$

$$\Delta U = (1/2)V\mu_0M^2[N - (1/2)(1-N)]$$

$$K_s = \frac{1}{4}\mu_0M_s^2(1 - 3N)$$

Anisotropy is zero for a sphere, as expected.

Shape anisotropy is effective in small, single-domain particles.

Order of magnitude of the anisotropy for $\mu_0M_s = 1 \text{ T}$ is 200 kJ m^{-3}

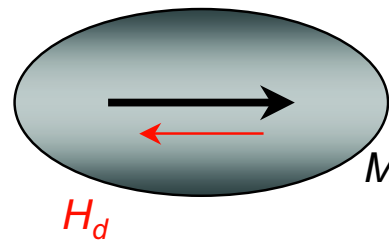
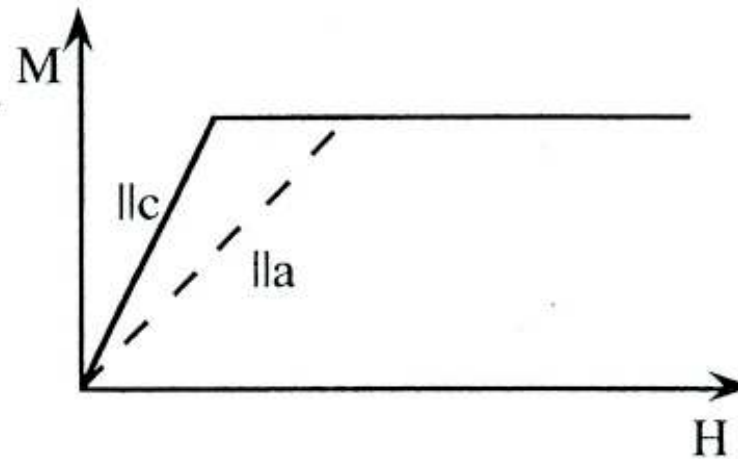

5.2. Magnetocrystalline anisotropy

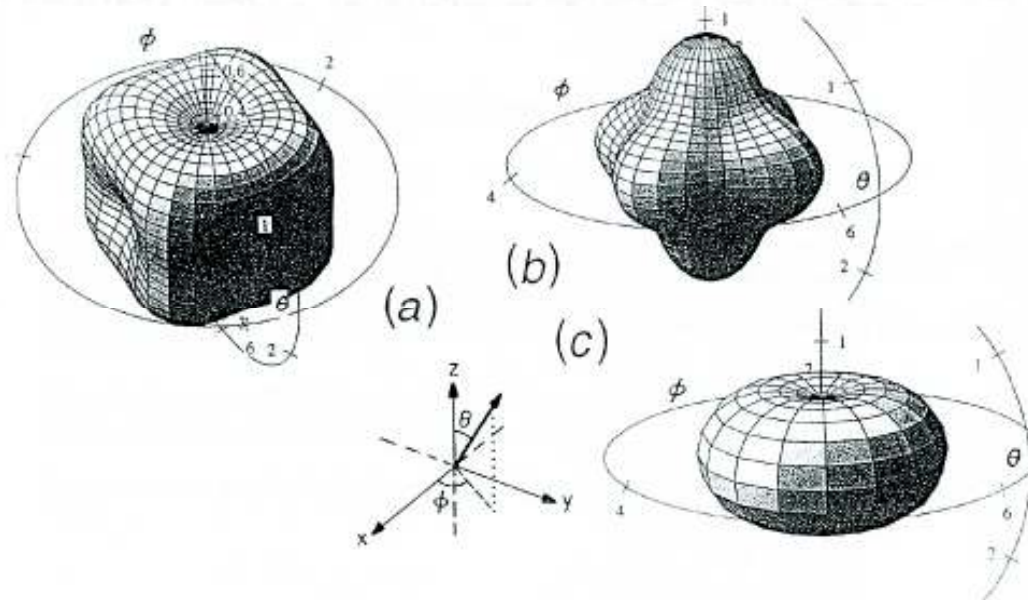
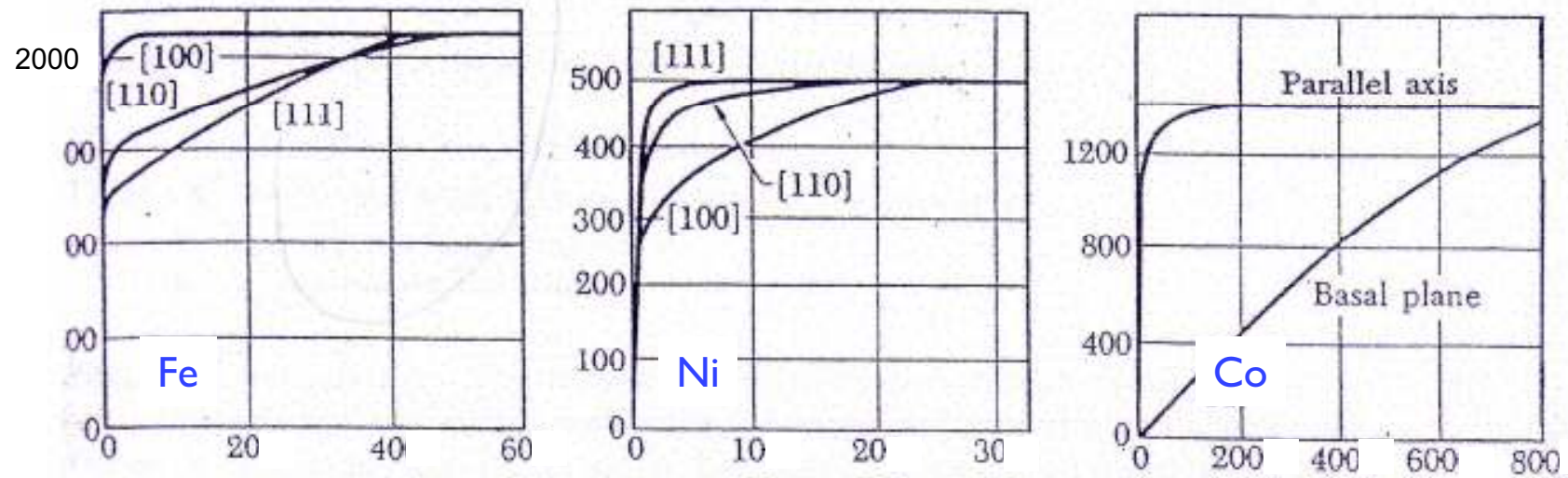

The conventional expressions for anisotropy in different symmetry are

$$\text{Hexagonal: } E_a = K_1 \sin^2 \theta + K_2 \sin^4 \theta + K_3 \sin^6 \theta + K_3' \sin^6 \theta \sin 6\phi$$

$$\text{Tetragonal: } E_a = K_1 \sin^2 \theta + K_2 \sin^4 \theta + K_2' \sin^4 \theta \cos 4\phi + K_3 \sin^6 \theta + K_3' \sin^6 \theta \sin 4\phi$$

$$\text{Cubic: } E_a = K_{1c}(\alpha_1^2 \alpha_2^2 + \alpha_2^2 \alpha_3^2 + \alpha_3^2 \alpha_1^2) + K_{2c}(\alpha_1^2 \alpha_2^2 \alpha_3^2)$$

where α_i are the direction cosines of the magnetization direction.

Cubic term is $K_{1c}(\sin^4 \theta \cos^2 \phi \sin^2 \phi + \cos^2 \theta \sin^2 \theta) \approx K_{1c} \sin^2 \theta$ when $\theta \approx 0$

An alternative way of writing the anisotropy expressions is in terms of a set of orthonormal Legendre polynomials and the anisotropy coefficients κ_n^m .

$$E_a = \sum_{l=2,4,6} \kappa_l^m A_l^m Y_l^m(\theta, \phi)$$

so

$$E_a^{hex} = \kappa_0 + \kappa_2^0(a^2 - 1/3) + \kappa_4^0(a^4 - (6/7)a^2 + 3/35) + .. \quad \text{with } \alpha = \cos \theta.$$

$$E_a^{cubic} = \kappa_0 + \kappa_4^4(\alpha_1^2 \alpha_2^2 + \alpha_2^2 \alpha_3^2 + \alpha_3^2 \alpha_1^2 - 1/5) + \kappa_6^4(\alpha_1^2 \alpha_2^2 \alpha_3^2 - (1/11)(\alpha_1^2 \alpha_2^2 + \alpha_2^2 \alpha_3^2 + \alpha_3^2 \alpha_1^2 - 1/5) - 1/105)$$

This shows clearly that K_{1c} relates to fourth-order anisotropy, whereas K_1 in uniaxial structures relates to second-order anisotropy.

Phase diagram for

$$E_a = K_1 \sin^2 \theta + K_2 \sin^4 \theta$$

Minimize energy wrt θ

$$0 = 2K_1 + 4K_2 \sin^2 \theta$$

Easy cone when $K_1 < 0, K_2 > -K_1/2$

To deduce K_1 and K_2 , plot H/M vs M^2 for $H \perp$ easy axis.

$$\text{Minimize } E = E_a - M_s H \sin \theta$$

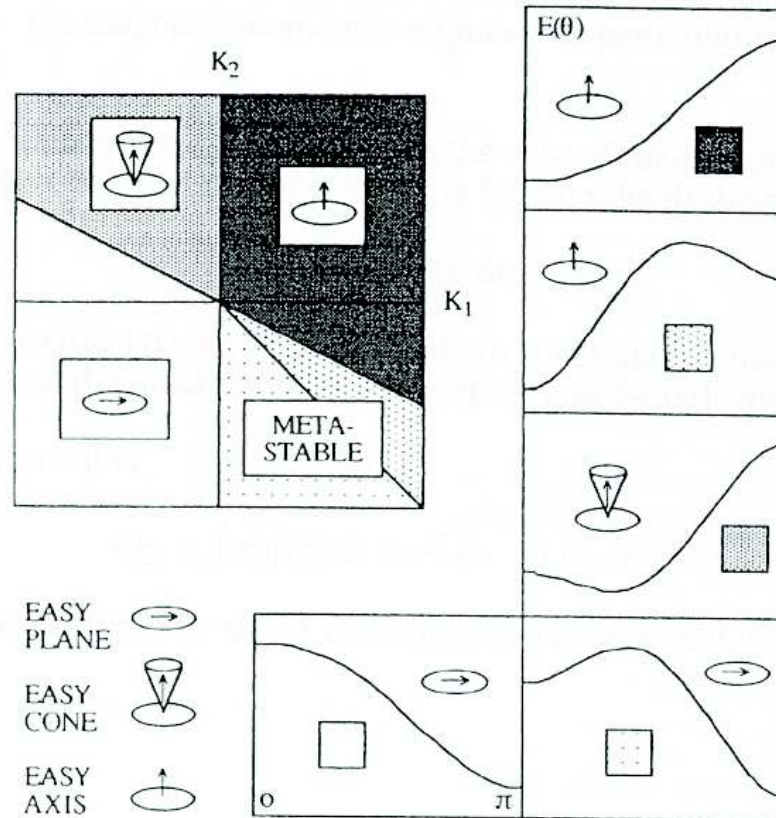

5.3. Origin of magnetocrystalline anisotropy

- Single-ion contributions (crystal field interaction) Must sum individual single-ion terms.

$$0 < K_U < 10 \text{ MJ m}^{-3}$$

- Two-ion contributions (magnetic dipole interactions)

$$0 < K_U < 100 \text{ kJ m}^{-3} \quad \uparrow \uparrow \quad \rightarrow \rightarrow$$

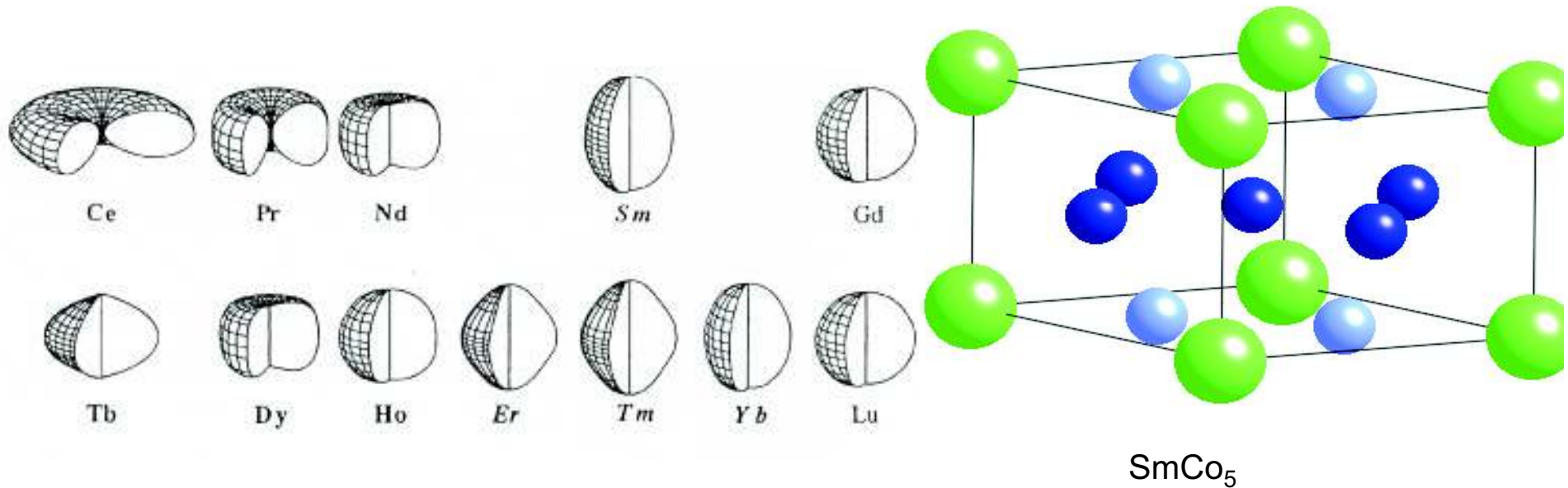

5.3. Induced anisotropy

- Stress: $K_{u \text{ stress}} = (3/2)\sigma\lambda_s$
- Magnetic field anneal: Pairwise texture in binary alloys such as Fe-Ni. →→

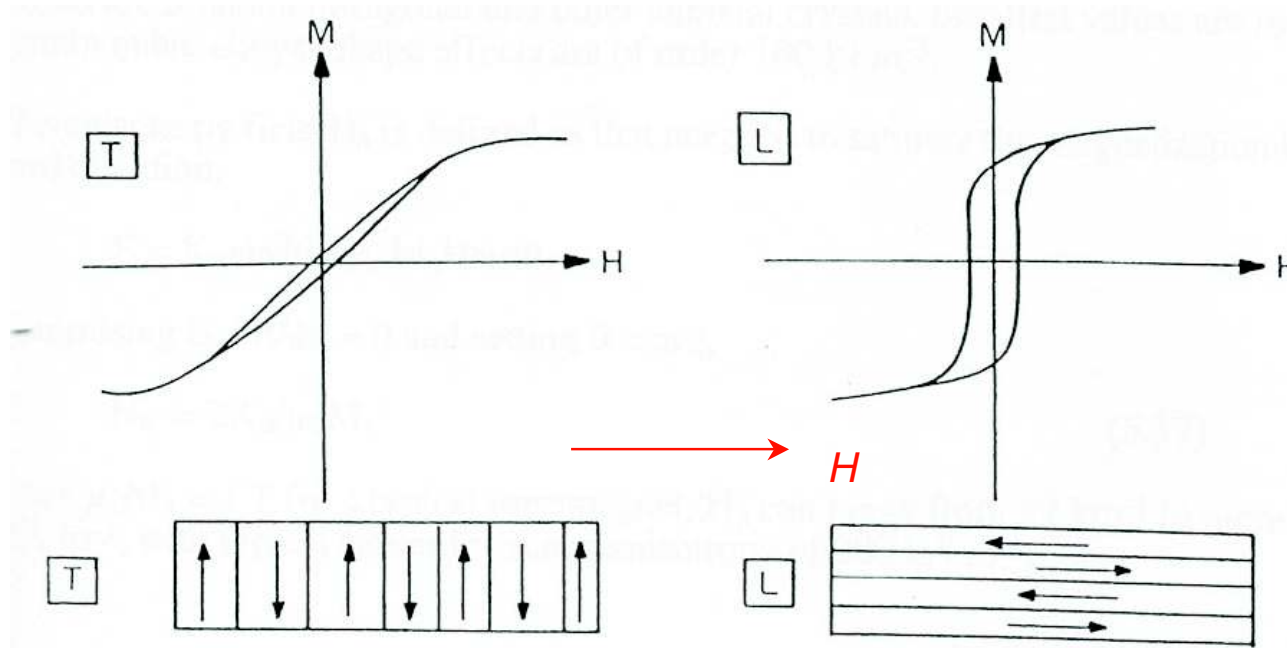

Anisotropy field.

The *anisotropy field* H_a is defined as the field needed to saturate the magnetization in a hard direction.

$$E = K_u \sin^2 \theta - \mu_0 M_s H \cos(\pi/2 - \theta)$$

Minimising E , $\partial E/\partial \theta = 0$ and setting $\theta = \pi/2$,

$$H_a = 2K_u/\mu_0 M_s \quad (7.52)$$

Since $\mu_0 M_s \approx 1$ T for a typical ferromagnet, H_a can range from < 2 kAm⁻¹ to more than 20 MA m⁻¹, with typical values for shape anisotropy of 200 kA m⁻¹. An equivalent definition of anisotropy field is the applied field along the easy axis which reproduces the change in energy due to a small deviation of the magnetization from this axis. Hence $K_u \sin^2 \delta\theta = H_a M_s (1 - \cos \delta\theta)$, which gives the same result

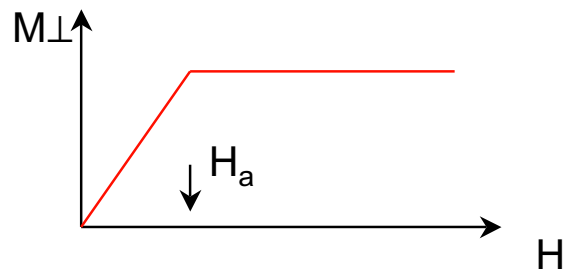

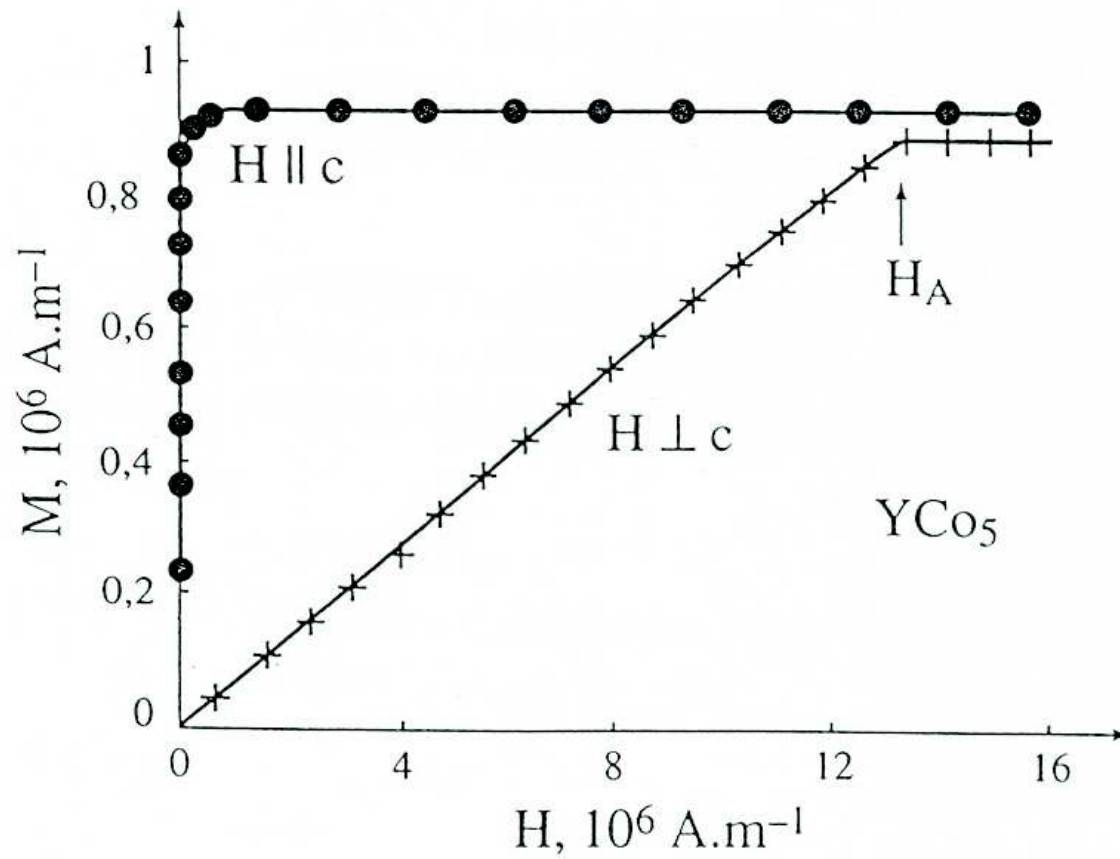

Summary of anisotropy

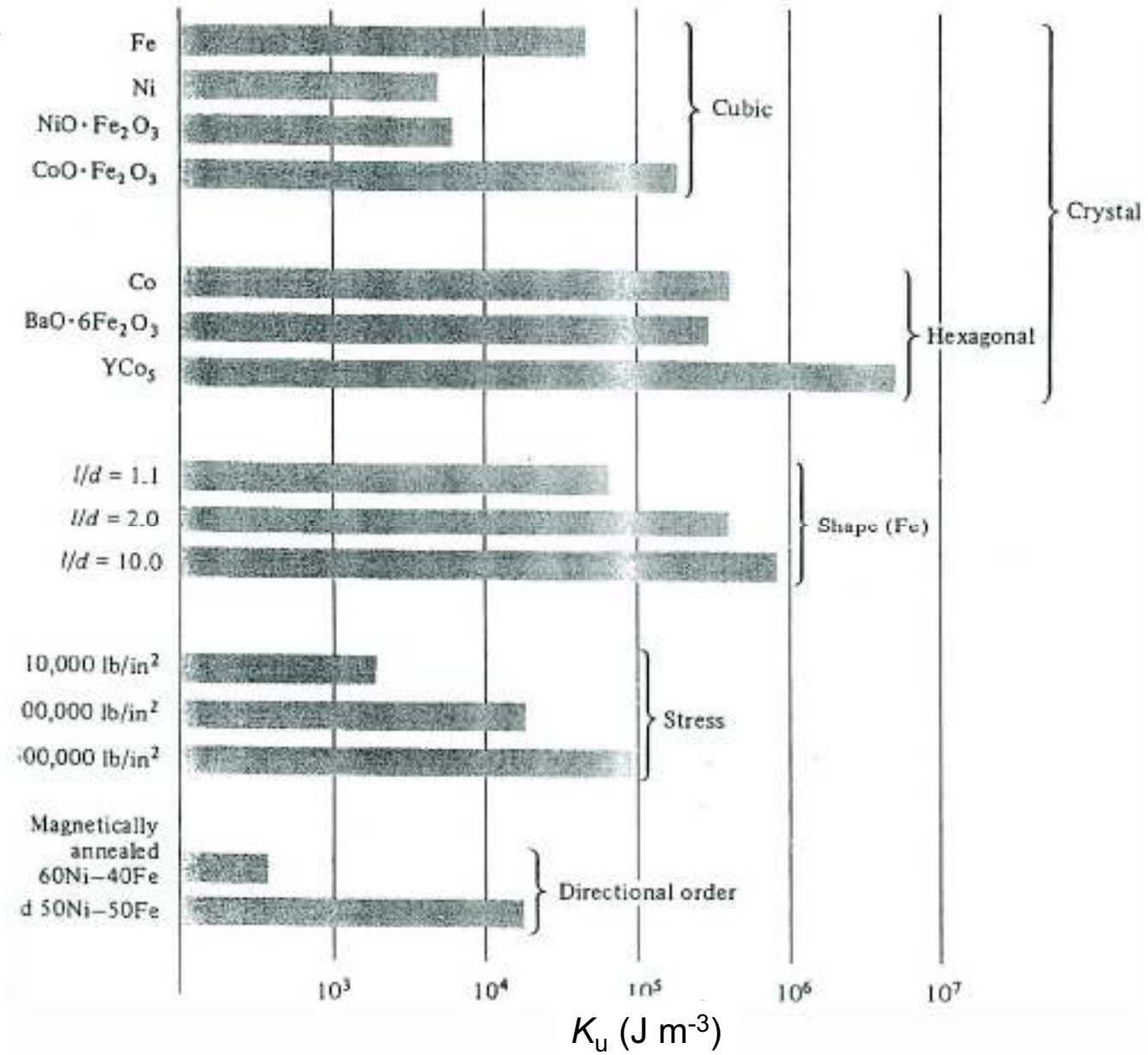

5.5. Temperature dependence

Magnetocrystalline anisotropy of single-ion origin of order l ($l = 2,4,6$) varies as $M^{i(l+1)/2}$

This gives 3, 10 and 21 power laws for the temperature dependence at low temperature. Close to T_C the law is 2,4 or 6.

Magnetocrystalline anisotropy of two-ion (dipole field) origin varies as M^2 .

6. Ferromagnetic phenomema

6.1 Magnetoelastic effects

Magnetoelastic effects		
	Isotropic	Anisotropic
Atomic spacing	Spontaneous and forced volume magnetostriction	Spontaneous linear magnetostriction and magnetostrictive strain
Elastic moduli	Anomalous thermal expansion Anomalous elastic moduli	Morphic effect ΔE effect

Invar effect $Fe_{30}Ni_{70}$

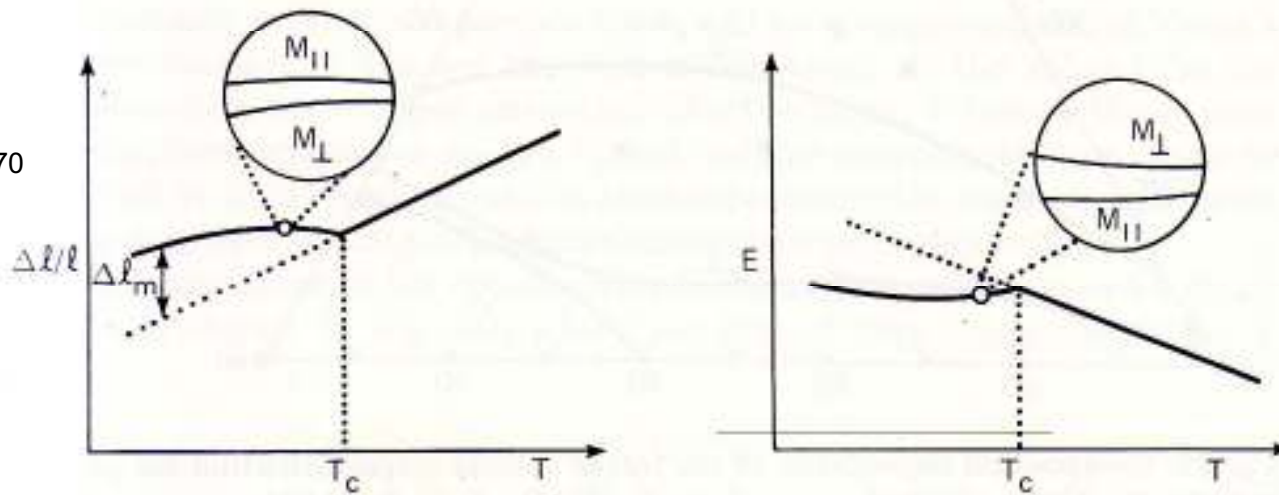

7.2 Magnetostriction

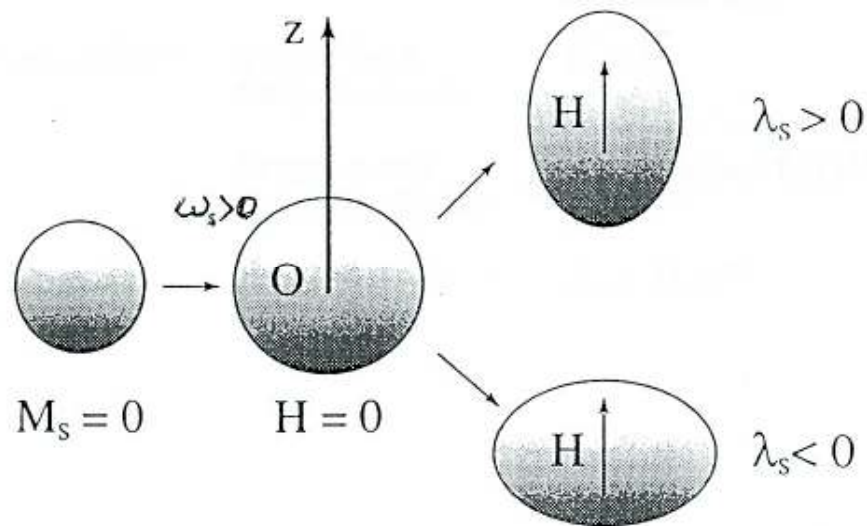

Volume ~ 1%

Linear ~ $10 \cdot 10^{-6}$

$$\epsilon_{ij} = \lambda_{ijk} M_k$$

Magnetostriction is a third rank tensor

$$\lambda_s = (2/5)\lambda_{100} + (3/5)\lambda_{111}$$

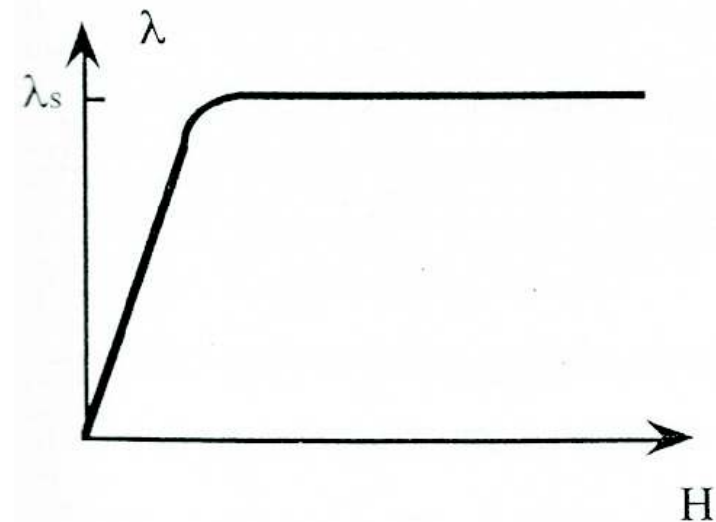

Transformer hum

Uniaxial stress → anisotropy, modifies permeability.

Helical field or current → torque; Torque → emf

7.3 Magnetocaloric effect

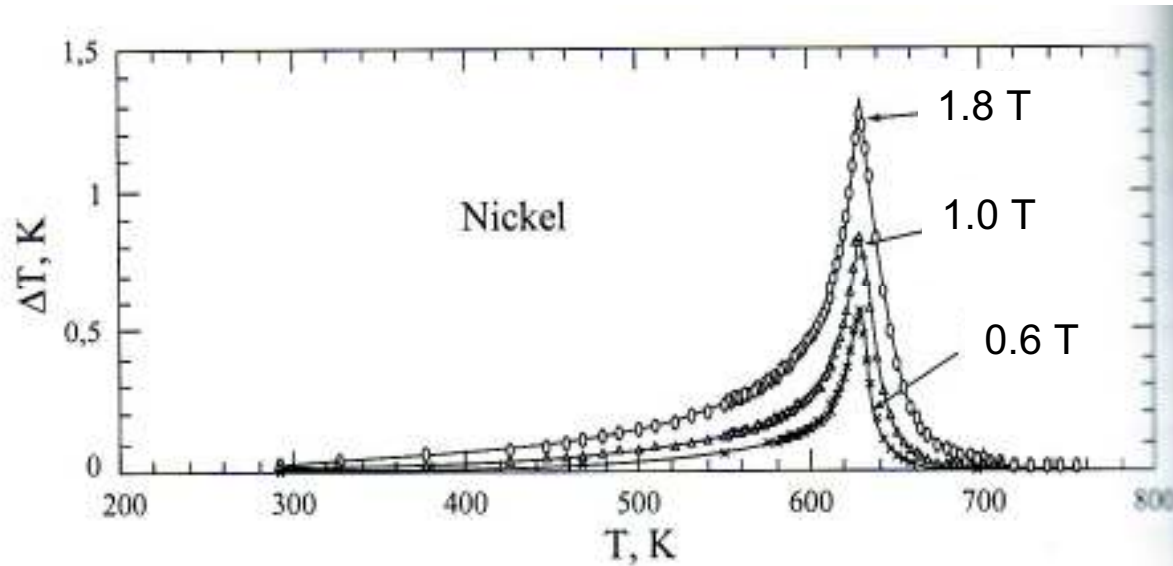

Magnetic refrigeration: Around T_C

Adiabatic demagnetization: $S = S(B/T)$;

$$B_1/T_1 = B_2/T_2$$

You cannot reach absolute zero!

6.5 Magnetoresistance

Anisotropic Magnetoresistance (AMR)

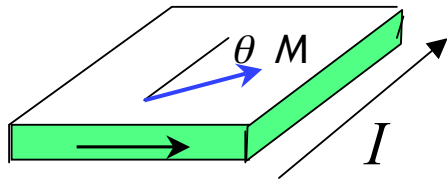

thin film

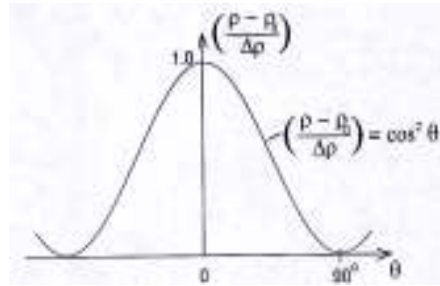

Discovered by W. Thompson in 1857

$$\rho = \rho_0 + \Delta\rho \cos^2 \theta$$

Magnitude of the effect $\Delta\rho/\rho < 3\%$ The effect is usually positive; $\rho_{||} > \rho_{\perp}$

Maximum sensitivity $d\rho/d\theta$ occurs when $\theta = 45^\circ$. Hence the 'barber-pole' configuration used for devices.

AMR is due to spin-orbit s - d scattering

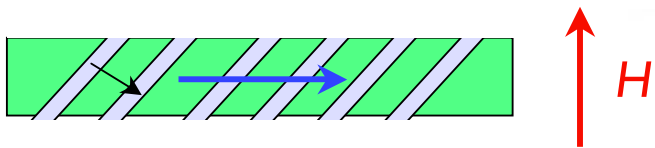
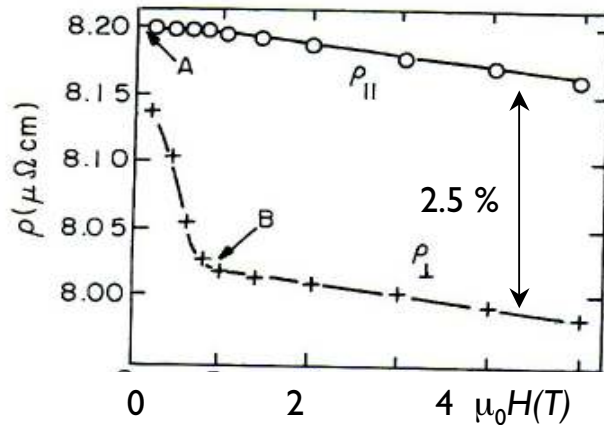

Resistivity tensor for isotropic material in a magnetic field:

ρ_{xx}	$-\epsilon_{xy}$	0
ρ_{xy}	ϵ_{xx}	0
0	0	ρ_{zz}

ρ_{xy} is the Hall resistivity.

$$\rho_{xy} = \mu_0 (R_0 H + R_m M)$$

Normal Hall effect

Anomalous Hall effect

6.6 Magneto-optics

Faraday effect: (transmission)

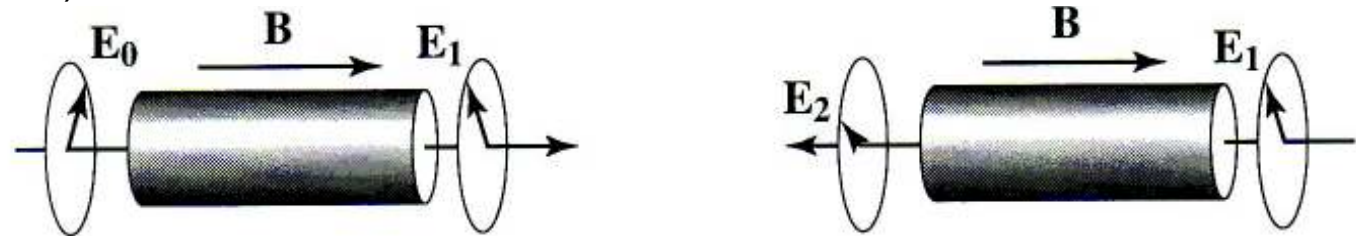

Kerr effect: (reflection)

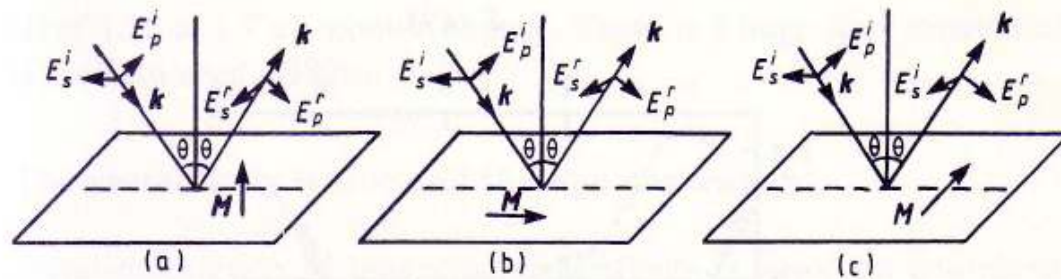

Dichroism and birefringence

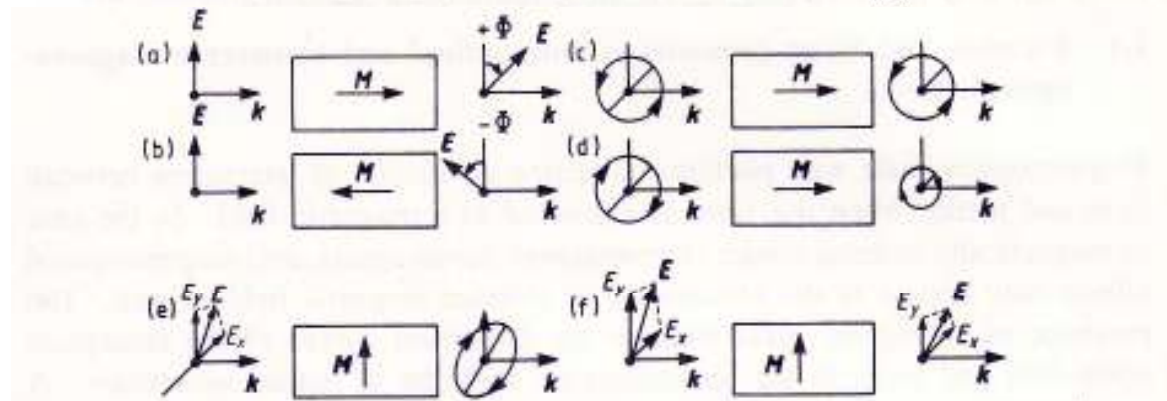

Magneto-optical effects resulting from the interaction of optical radiation with the medium: magnetic circular birefringence ((a), (b)), magnetic circular dichroism ((c), (d)), magnetic linear birefringence (e), and magnetic linear dichroism (f).

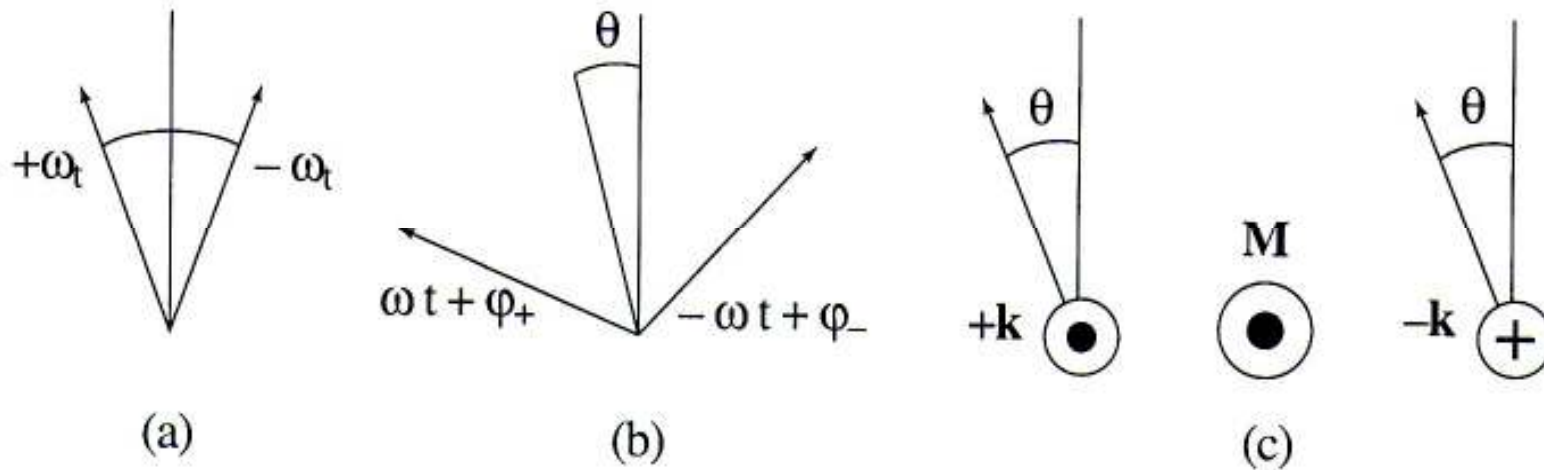

A plane-polarised wave is decomposed into the sum of two, counter-rotating circularly-polarized waves (a) which become dephased because they propagate at different velocities (b) through the magnetized solid. The Faraday rotation θ is non-reciprocal - independent of direction of propagation.

Magneto optic tensor for isotropic material in a magnetic field:

ϵ_{xx}	$-\epsilon_{xy}$	0
ϵ_{xy}	ϵ_{xx}	0
0	0	ϵ_{zz}

ϵ_{xy} is the dielectric constant

