

SUPERHETERODYNE SPECTRUM ANALYZER

TOPICS

- **Superheterodyne spectrum analyzer**
 - **Basic architecture**
 - **Frequency resolution**
 - **Sweep time**
 - **Video section**

BASIC ARCHITECTURE

Superheterodyne Technique

Mixer: real case

$$\text{Output frequencies} = \left| m \cdot f_{lo} \pm n \cdot f_{sig} \right|$$

m and n integer, zero included



f_{sig} , f_{lo} are present in output



For reliable measurements :

Input signal must not contain f_{IF} !

Operating choices along the frequency axis

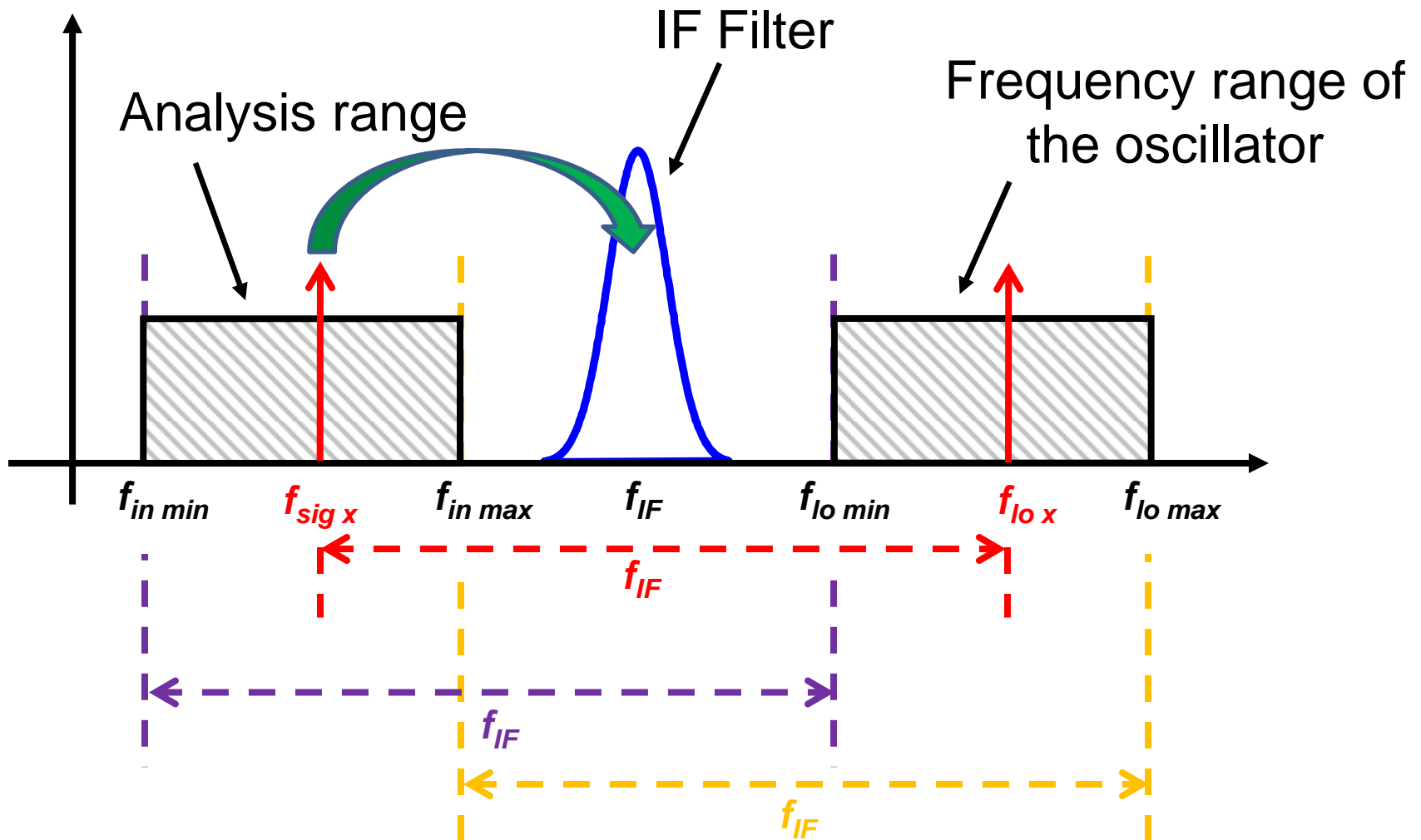

Operating choices along the frequency axis

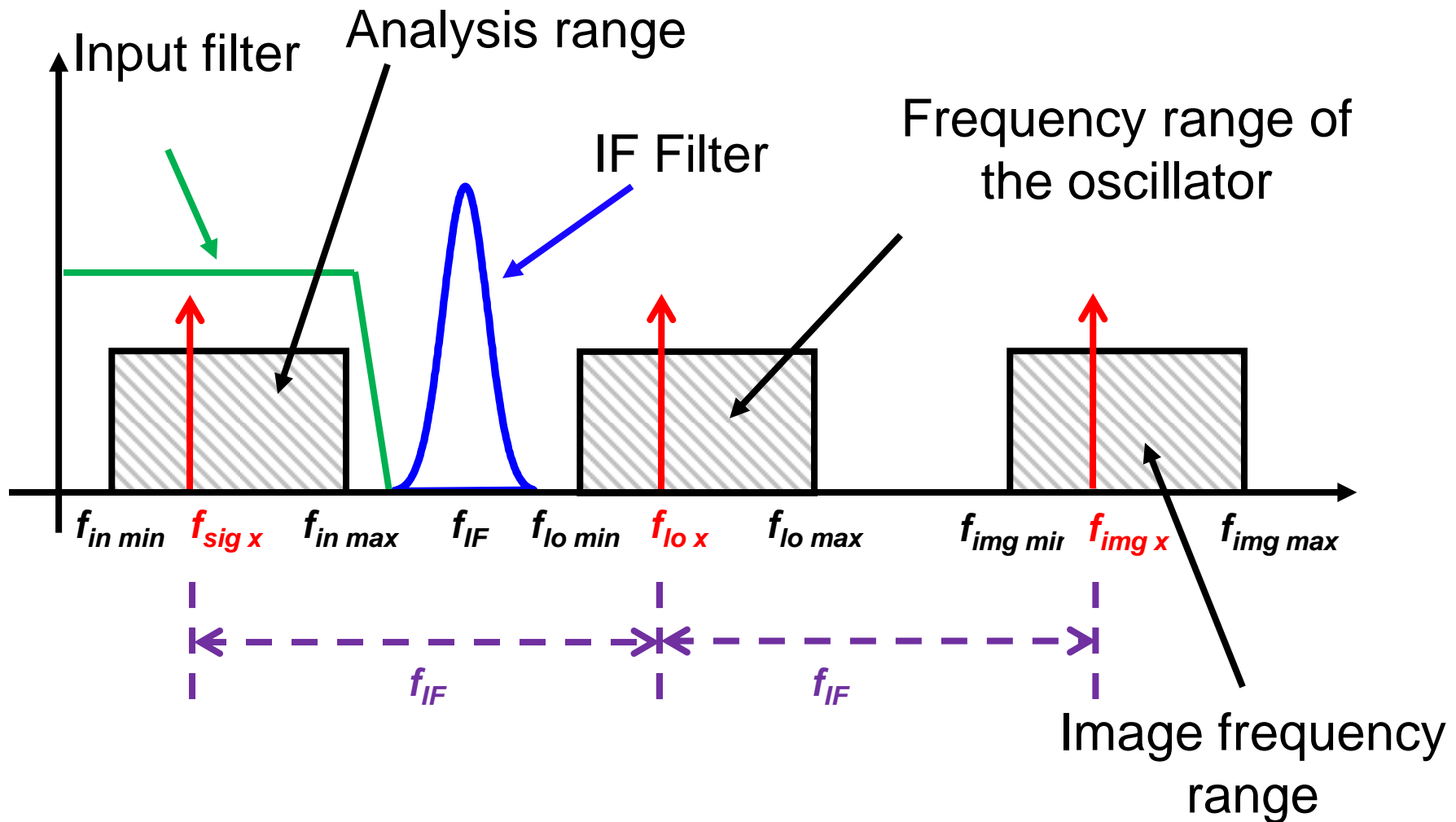

Basic architecture

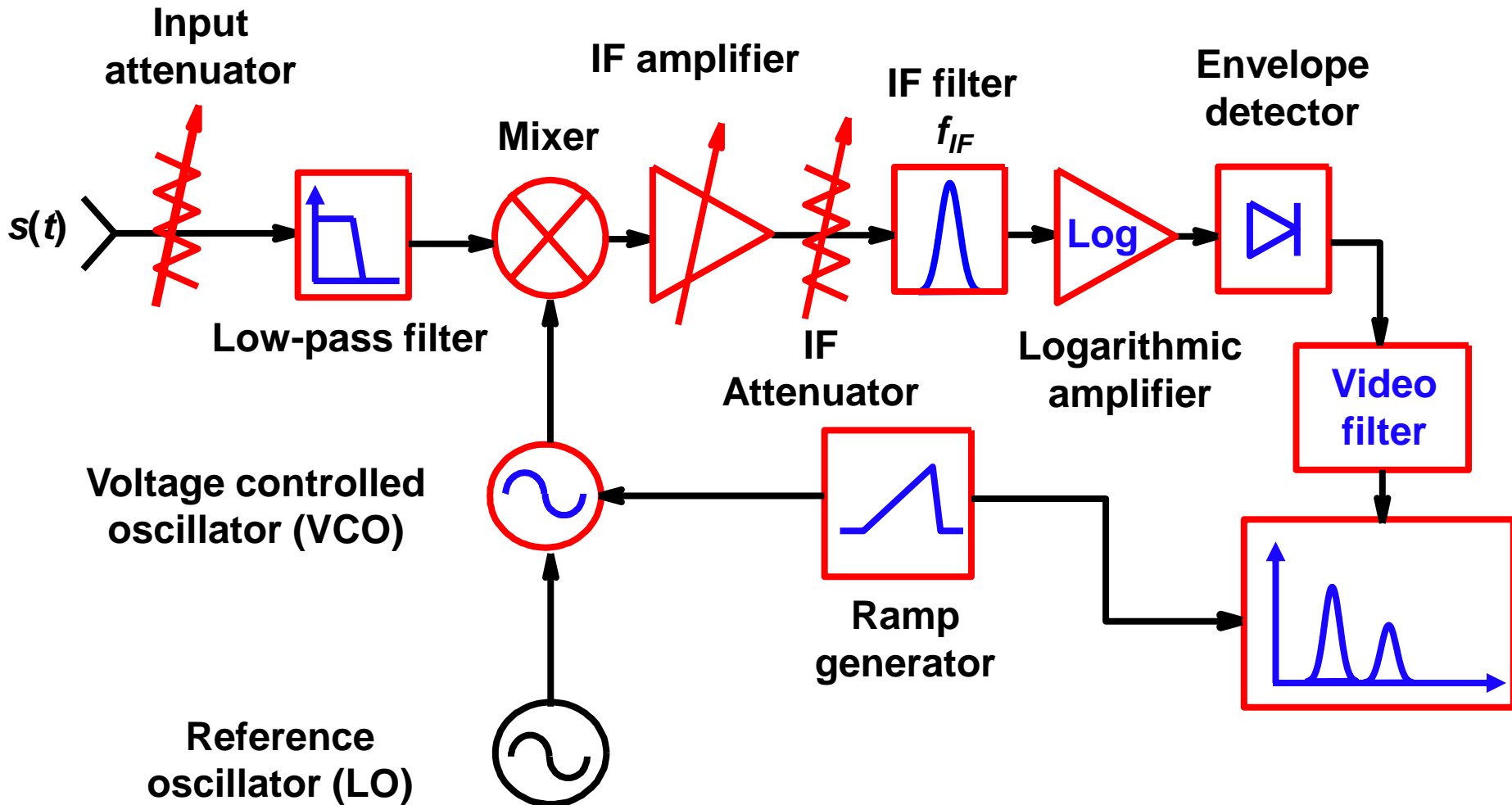

Example of measured spectrum

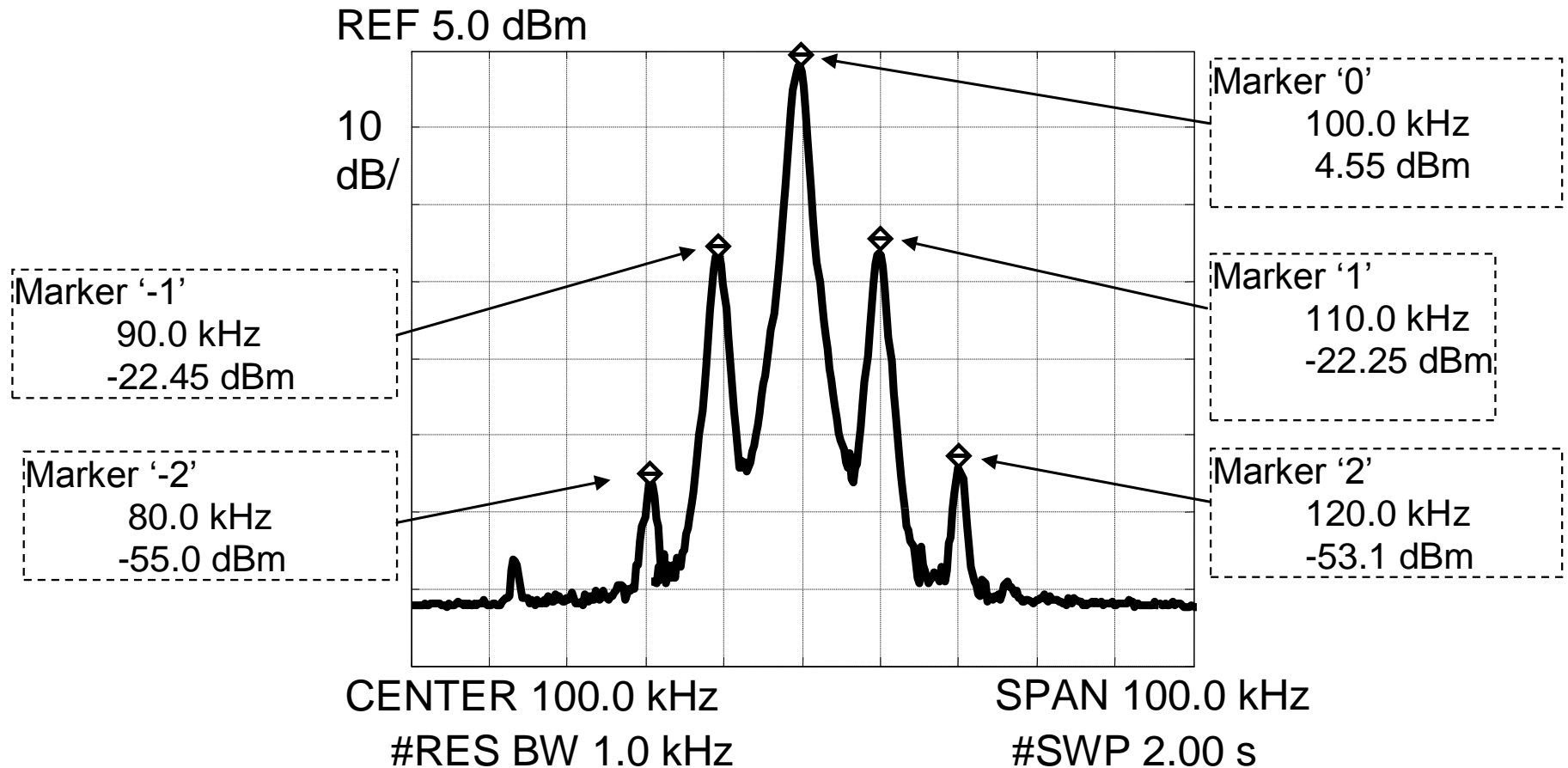

FREQUENCY RESOLUTION

Frequency resolution

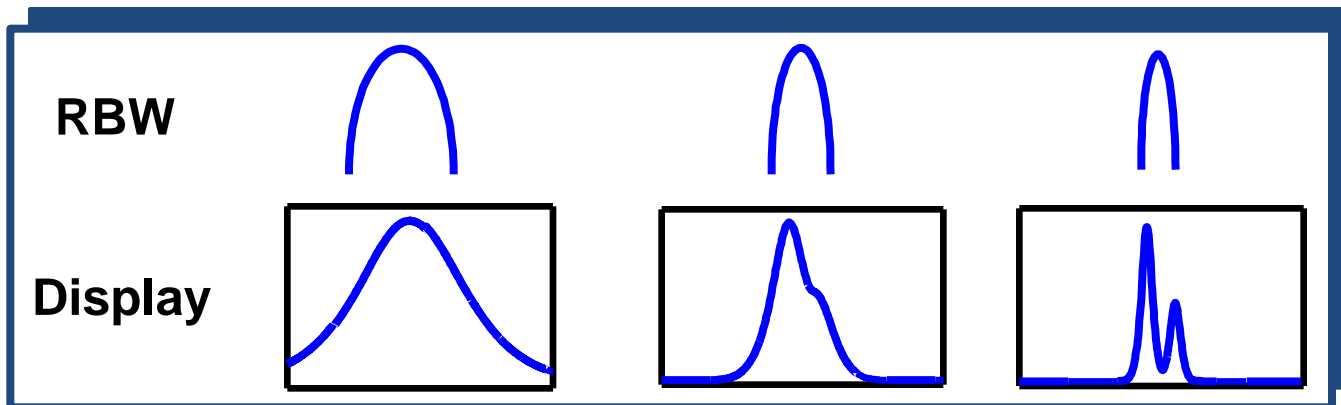
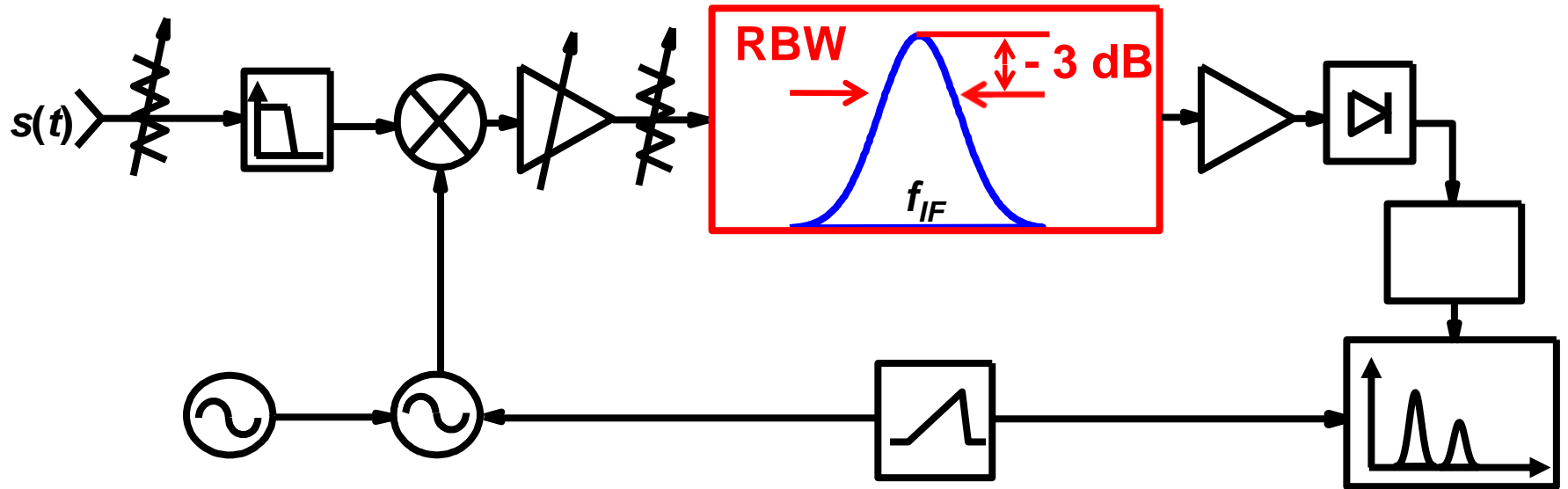

Frequency resolution

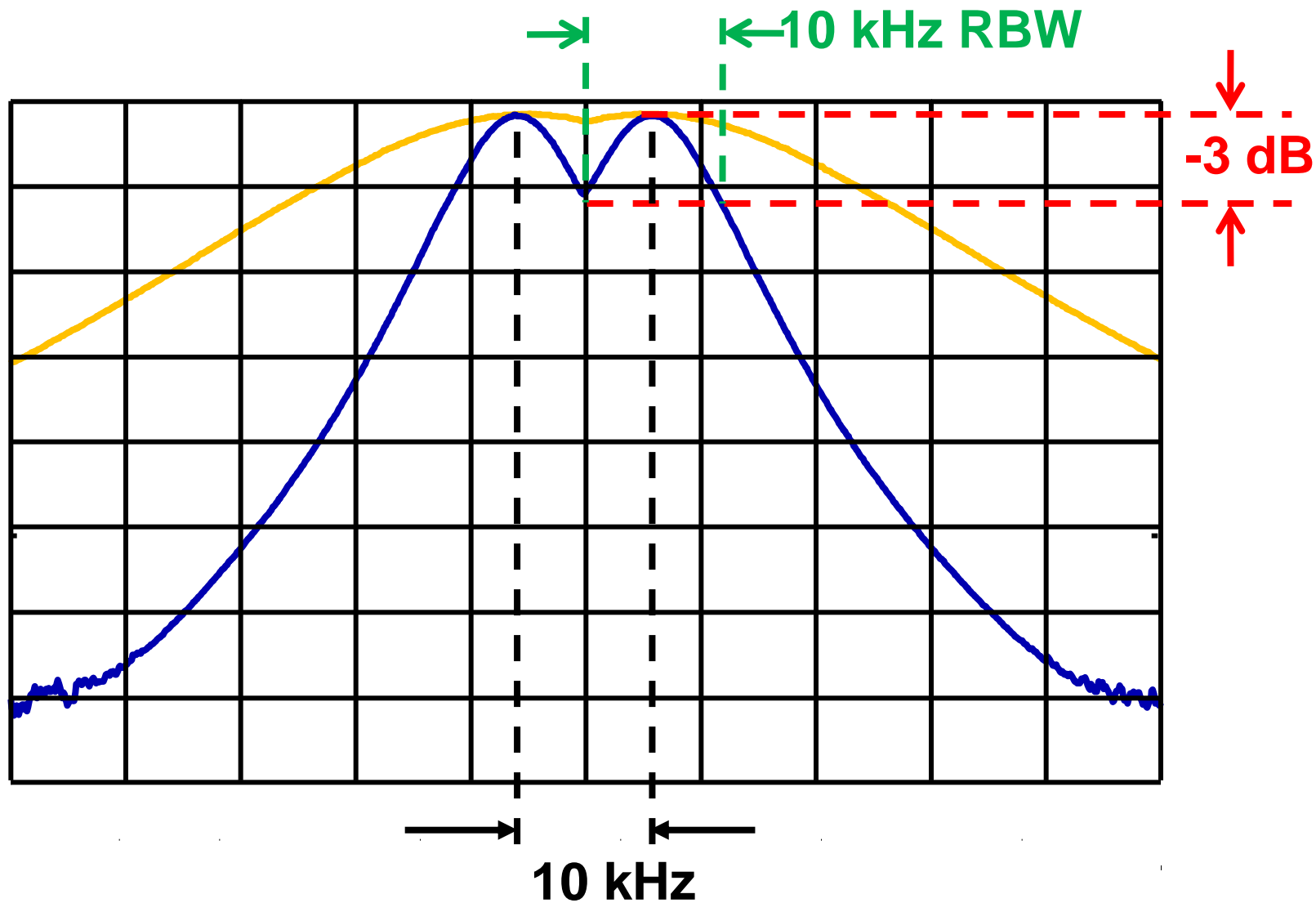

Selectivity

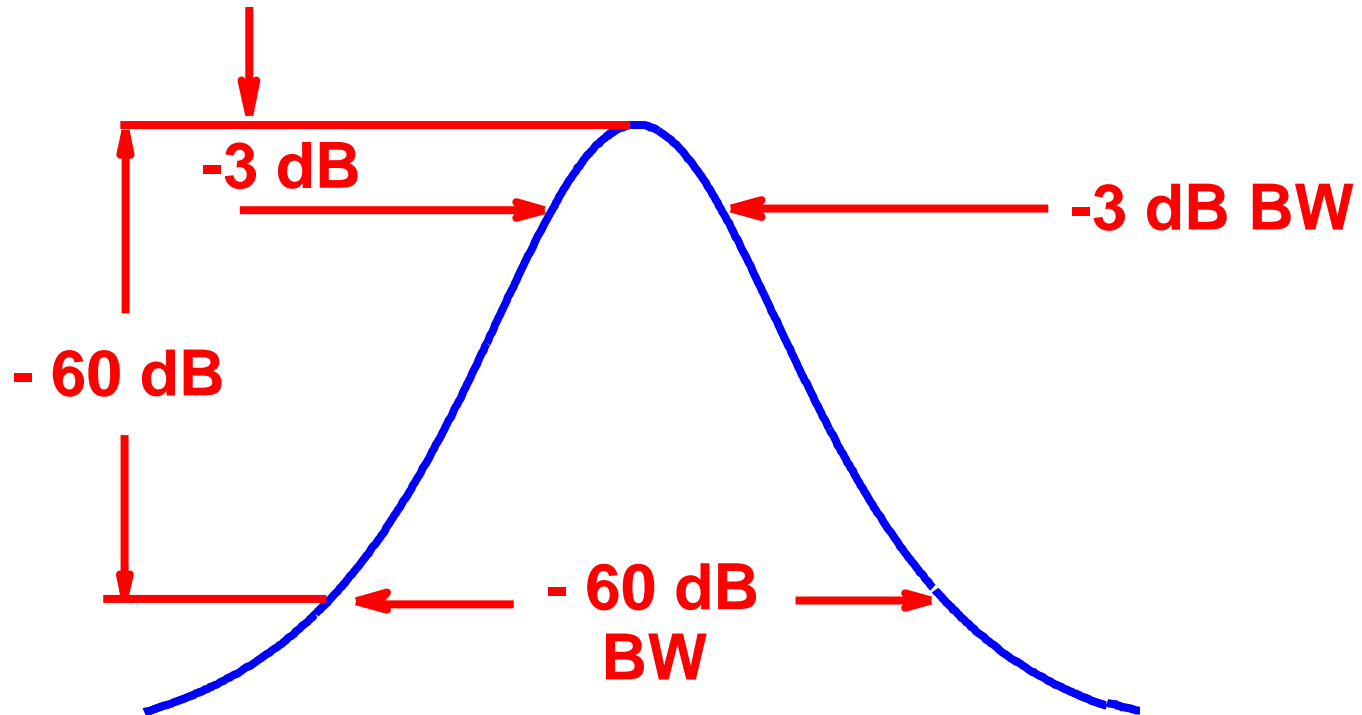

$$\text{Selectivity} = \frac{-60 \text{ dB BW}}{-3 \text{ dB BW}}$$

Resolution vs Selectivity

RBW = 1 kHz
Selectivity 15:1

RBW = 10 kHz

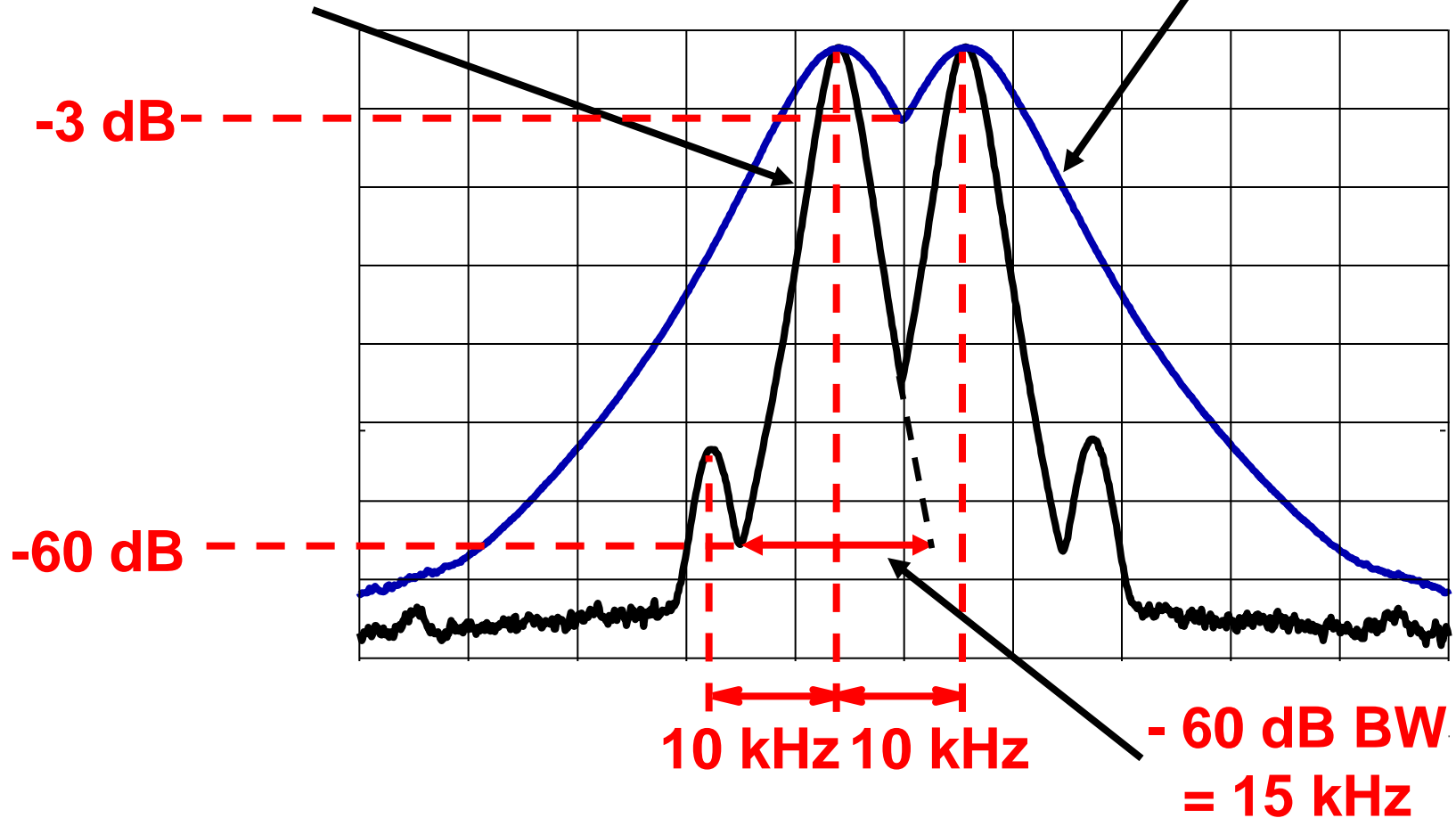

SWEEP TIME

Sweep Time (ST)

- Time taken to scan the frequency range of interest (*span*)
- Time interval covered by the ramp provided by the generator

✓ V_{sw} , sweep speed

$$V_{sw} = \frac{span}{ST}$$

Sweep Time

- ✓ τ , IF filter response time

$$\tau = \frac{k}{RBW}$$

- ✓ t , time during which a spectral component remains within the IF filter bandwidth

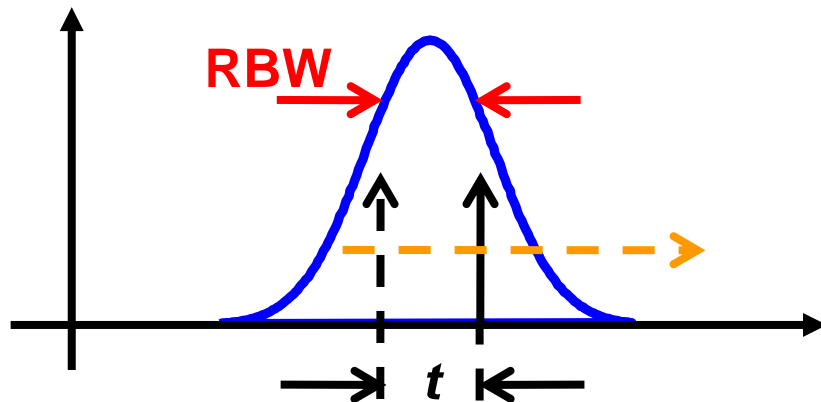

$$t = \frac{RBW}{V_{SW}}$$

Sweep Time

- To carry out reliable measurements

$$\frac{RBW}{V_{sw}} = \frac{RBW}{span/ST} > \frac{k}{RBW}$$

$$ST > \frac{k \cdot span}{RBW^2}$$

ST is in inverse relation to the square of RBW !

Sweep Time

- If the relation is not satisfied....

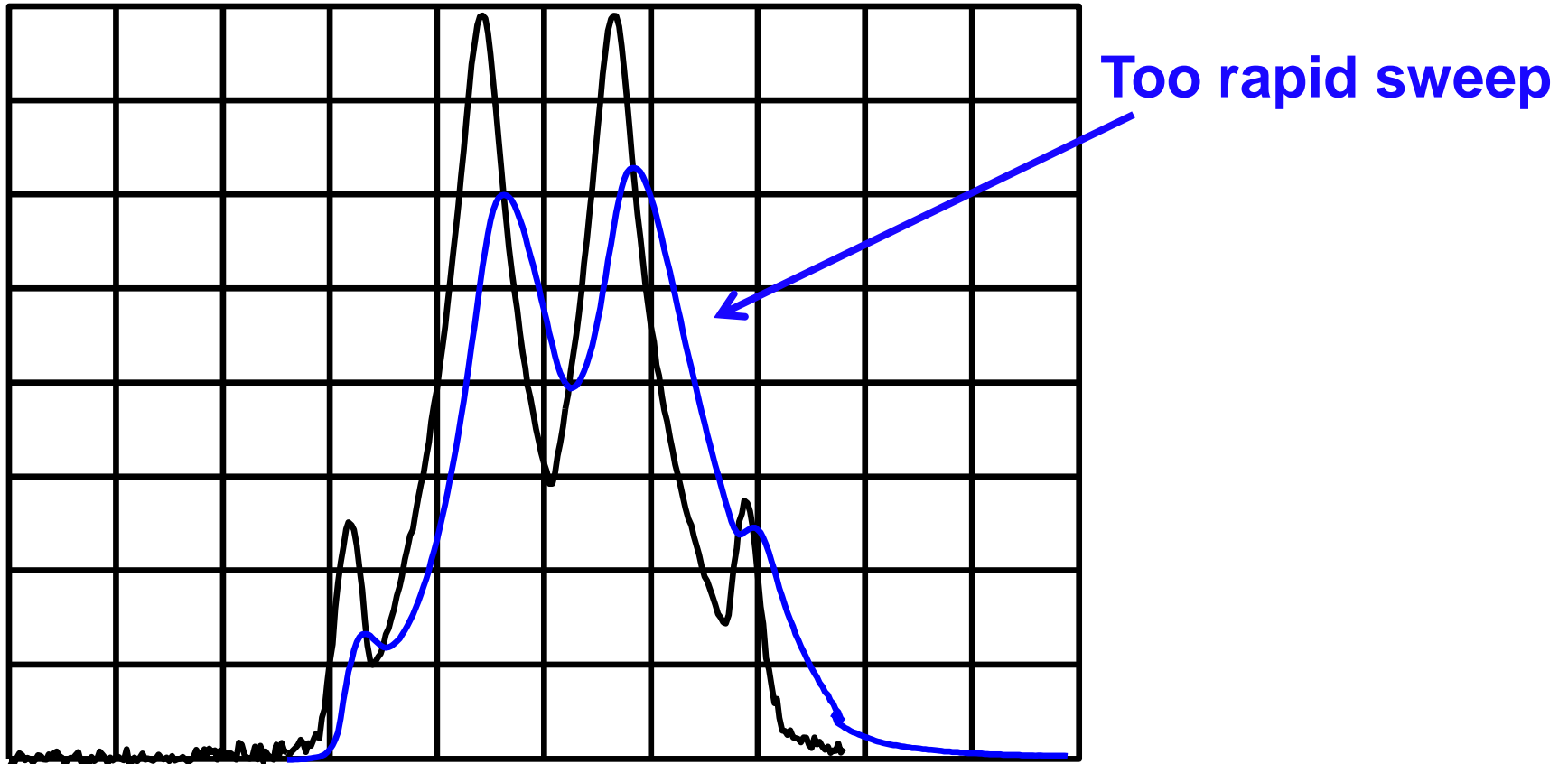

VIDEO SECTION

Envelope detector

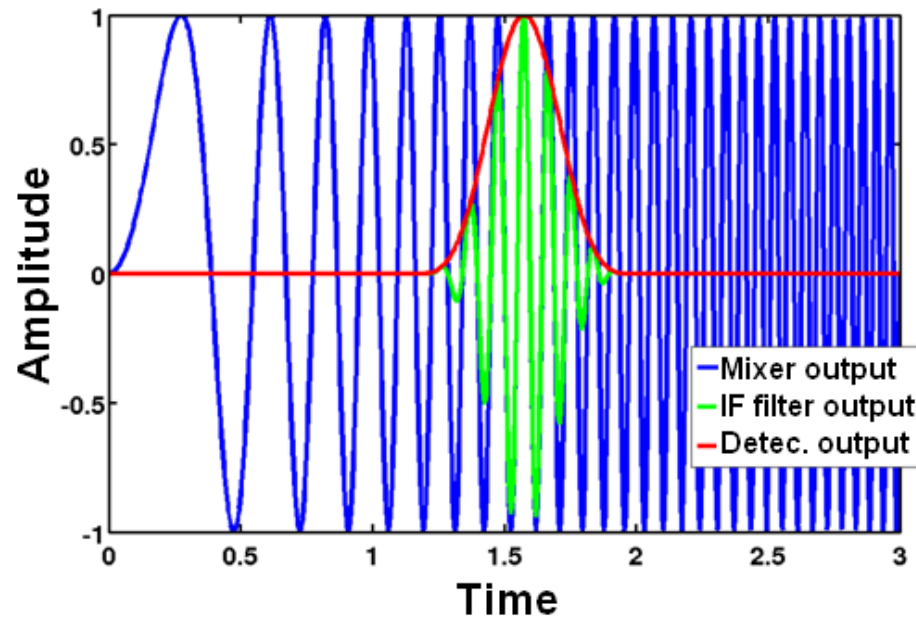
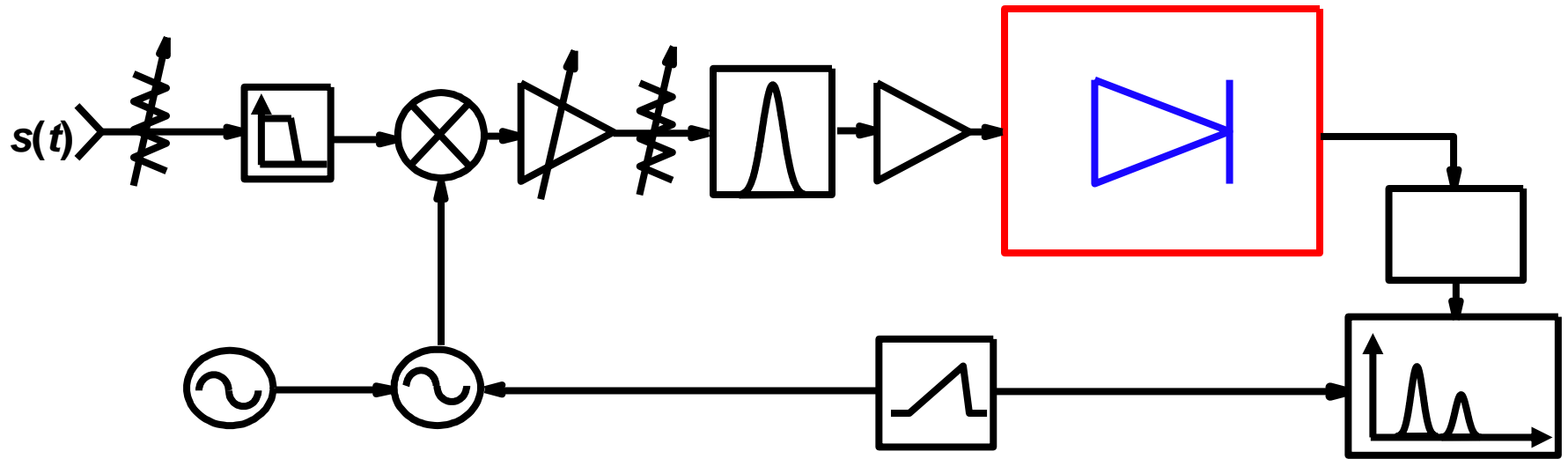

Video filter

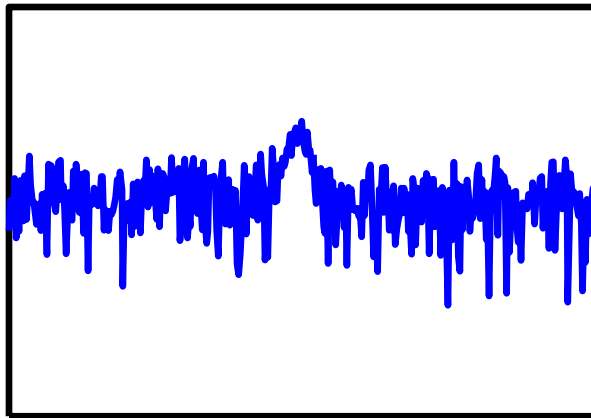
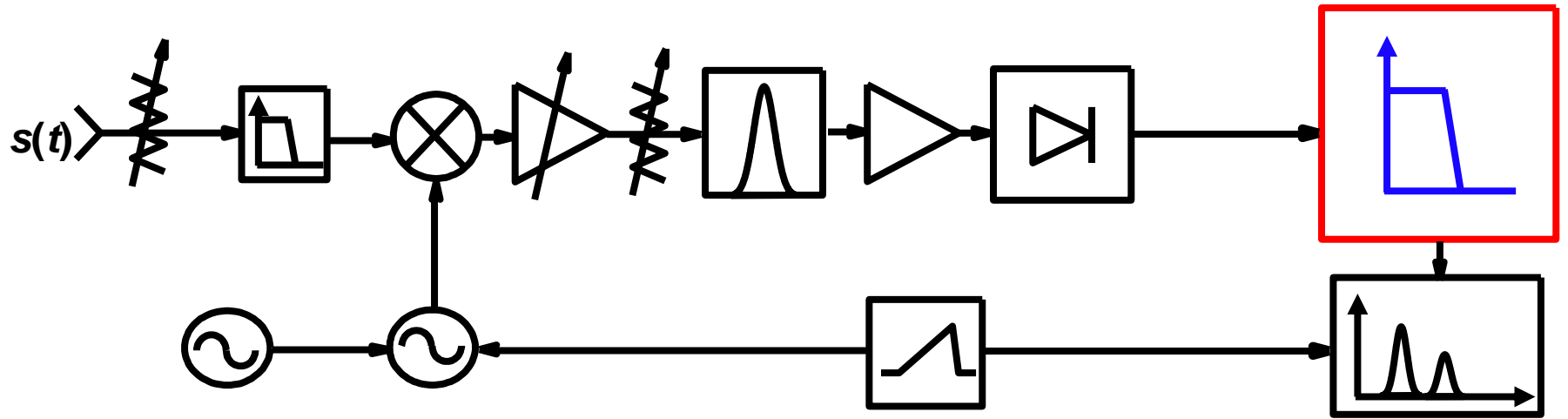

before

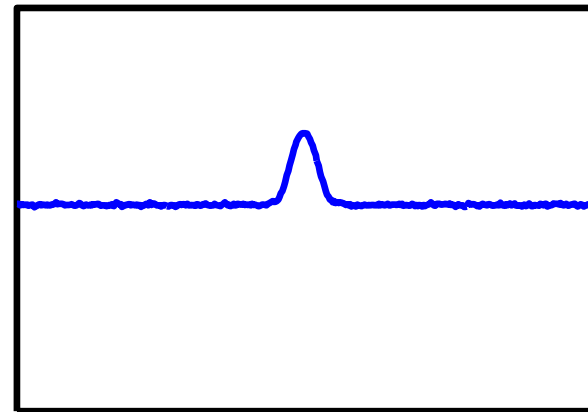

after