

# Contents

<b>1</b>	<b>Introduction</b>	<b>1</b>
1.1	Non euclidean geometries . . . . .	1
1.2	How does the metric tensor transform if we change the coordinate system . .	4
1.3	Summary . . . . .	6
1.4	The newtonian theory . . . . .	7
1.5	The role of the Equivalence Principle in the formulation of the new theory of gravity . . . . .	10
1.6	The geodesic equations as a consequence of the Principle of Equivalence . . .	11
1.7	Summary . . . . .	13
1.8	Locally inertial frames . . . . .	13
1.9	Appendix 1A . . . . .	14
1.10	Appendix 1B . . . . .	15
<b>2</b>	<b>Topological Spaces, Mapping, Manifolds</b>	<b>16</b>
2.1	Topological spaces . . . . .	16
2.2	Mapping . . . . .	17
2.3	Composition of maps . . . . .	19
2.4	Continuous mapping . . . . .	20
2.5	Differentiable mapping . . . . .	21
2.6	Manifolds . . . . .	21
<b>3</b>	<b>Vectors and One-forms</b>	<b>25</b>
3.1	The traditional definition of a vector . . . . .	25
3.2	A geometrical definition . . . . .	26
3.3	The directional derivative along a curve form a vector space at P . . . . .	28
3.4	Coordinate bases . . . . .	31
3.5	One-forms . . . . .	34
<b>4</b>	<b>Tensors</b>	<b>40</b>
4.1	Geometrical definition of a Tensor . . . . .	40
4.2	Symmetries . . . . .	44
4.3	The metric Tensor . . . . .	45
4.3.1	The metric tensor allows to compute the distance between two points	48
4.3.2	The metric tensor maps vectors into one-forms . . . . .	50

<b>5</b>	<b>Affine Connections and Parallel Transport</b>	<b>52</b>
5.1	The covariant derivative of vectors . . . . .	52
5.1.1	$V^\alpha_{;\beta}$ are the components of a tensor . . . . .	53
5.2	The covariant derivative of one-forms and tensors . . . . .	55
5.3	The covariant derivative of the metric tensor . . . . .	56
5.4	Symmetries of the affine connections . . . . .	56
5.5	The relation between the affine connections and the metric tensor . . . . .	57
5.6	Appendix C non coordinate basis . . . . .	59
5.7	Summary of the preceding chapters . . . . .	62
5.8	Parallel Transport . . . . .	63
5.9	Geodesics are those curves which parallel-transport their own tangent vectors	66
<b>6</b>	<b>The Curvature Tensor</b>	<b>68</b>
6.1	a) A Formal Approach . . . . .	68
6.2	b) The curvature tensor and the curvature of the spacetime . . . . .	71
6.3	Symmetries . . . . .	74
6.4	The Riemann tensor gives the commutator of covariant derivatives . . . . .	74
6.5	The Bianchi identities . . . . .	75
<b>7</b>	<b>The stress-energy tensor</b>	<b>76</b>
7.1	The Principle of General Covariance . . . . .	83
<b>8</b>	<b>The Einstein equations</b>	<b>86</b>
8.1	The geodesic equations in the weak field limit . . . . .	87
8.2	The Einstein's field equations . . . . .	89
8.3	Gauge invariance of the Einstein equations . . . . .	92
8.4	Example: The armonic gauge. . . . .	95
<b>9</b>	<b>Symmetries</b>	<b>97</b>
9.1	The Killing vectors . . . . .	97
9.1.1	Lie-derivative . . . . .	99
9.1.2	Killing vectors coordinate systems . . . . .	99
9.2	Examples . . . . .	100
9.3	Conserved quantities in geodesic motion . . . . .	102
9.4	Killing vectors and conservation laws . . . . .	103
9.5	Hypersurface orthogonal vector fields . . . . .	103
9.6	Appendix A . . . . .	105
9.7	Appendix B: The Levi-Civita completely antisymmetric pseudotensor . . . . .	106
<b>10</b>	<b>The Schwarzschild solution</b>	<b>108</b>
10.1	The symmetries of the problem . . . . .	108
10.2	The Birkhoff theorem . . . . .	112
10.3	Geometrized unities . . . . .	113
10.4	The singularities of Schwarzschild solution . . . . .	113
10.5	Spacelike, Timelike and Null Surfaces . . . . .	114

10.6	How to remove a coordinate singularity . . . . .	118
10.7	The Kruskal extension . . . . .	122
<b>11</b>	<b>Experimental Tests of General Relativity</b>	<b>127</b>
11.1	Gravitational redshift of spectral lines . . . . .	127
11.2	The geodesic equations in the Schwarzschild background . . . . .	130
11.2.1	Geodesics from a variational principle . . . . .	130
11.2.2	Geodesics in the Schwarzschild metric . . . . .	131
11.3	The orbits of a massless particle . . . . .	133
11.3.1	The deflection of light . . . . .	135
11.4	The orbits of a massive particle . . . . .	140
11.4.1	The radial fall of a massive particle . . . . .	144
11.4.2	The motion of a planet around the Sun . . . . .	148
<b>12</b>	<b>The Geodesic deviation</b>	<b>152</b>
12.1	The equation of geodesic deviation . . . . .	152
<b>13</b>	<b>Gravitational Waves</b>	<b>155</b>
13.1	A perturbation of the flat spacetime propagates as a wave . . . . .	157
13.2	How to choose the harmonic gauge . . . . .	160
13.3	Plane gravitational waves . . . . .	161
13.4	The $TT$ -gauge . . . . .	162
13.5	How does a gravitational wave affect the motion of a single particle . . . . .	163
13.6	Geodesic deviation induced by a gravitational wave . . . . .	164
<b>14</b>	<b>The Quadrupole Formalism</b>	<b>172</b>
14.1	The Tensor Virial Theorem . . . . .	176
14.2	How to transform to the $\mathbf{TT}$ -gauge . . . . .	179
14.3	Gravitational wave emitted by a harmonic oscillator . . . . .	181
14.4	How to compute the energy carried by a gravitational wave . . . . .	183
14.4.1	The stress-energy pseudotensor of the gravitational field . . . . .	183
14.4.2	The energy flux carried by a gravitational wave . . . . .	185
14.5	Gravitational radiation from a rotating star . . . . .	189
14.6	Gravitational wave emitted by a binary system in circular orbit . . . . .	196
14.7	Evolution of a binary system due to the emission of gravitational waves . . . . .	201
14.7.1	The emitted waveform . . . . .	204

# Chapter 1

## Introduction

General Relativity is the physical theory of gravity formulated by Einstein in 1916. It is based on the Equivalence Principle of Gravitation and Inertia, which establishes a fundamental connection between the gravitational field and the geometry of the spacetime, and on The Principle of General Covariance. General Relativity has changed quite dramatically our understanding of space and time, and the consequences of this theory, that we shall investigate in this course disclose interesting and fascinating new phenomena. The gravitational collapse and the formation of black holes, the existence of gravitational waves, the Big Bang of cosmological theories are, at least conceptually, in the common background of modern physicists.

The language of General Relativity is that of tensor analysis, or, in a more modern formulation, the language of differential geometry. There is no way of understanding the theory of gravity without knowing what is a manifold, or a tensor. Therefore we shall dedicate a few lectures to the development of the mathematical tools and techniques that are essential to describe the theory and the physical consequences. The first lecture will be dedicated to answer the following questions:

- 1) why does the newtonian theory become unappropriate to describe the gravitational field.
- 2) why do we need a tensor to describe the gravitational field, and we need to introduce the concept of manifold, metric, affine connections and other geometrical objects.
- 3) What is the role played by the equivalence principle in all that.

In the next lectures we shall rigorously define manifolds, vectors, tensors, and then, after introducing the principle of general covariance, we will formulate the Einstein equations.

But first of all, since as we have already anticipated there is a connection between the gravitational field and the geometry of the spacetime, let us introduce non-euclidean geometries, which are in some sense the precursors of general relativity.

### 1.1 Non euclidean geometries

In the prerelativistic years the arena of physical theories was the flat space of euclidean geometry which is based on the five Euclide's postulates. Among them the fifth has been the object of a millenary dispute: for over 2000 years geometers tried to show, without

succeeding, that the fifth postulate is a consequence of the other four. The postulate states *Consider two straight lines and a third straight line crossing the two. If the sum of the two internal angles (see figures) is smaller than  $180^\circ$ , the two lines will meet at some point on the side of the internal angles.*

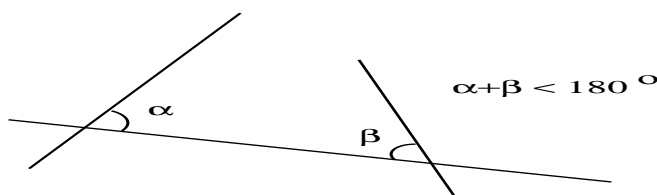

The solution to the problem is due to Gauss (1824, Germany), Bolyai (1832, Austria), and Lobachevski (1826, Russia), who independently discovered a geometry that satisfies all Euclidean's postulates except the fifth. This geometry is what we may call, in modern terms, a *two dimensional space of constant negative curvature*. The analytic representation of this geometry was discovered by Felix Klein in 1870. He found that a point in this geometry is represented as a pair of real numbers  $(x^1, x^2)$  with

$$(x^1)^2 + (x^2)^2 < 1, \quad (1.1)$$

and the distance between two points  $x$  and  $X$ ,  $d(x, X)$ , is defined as

$$d(x, X) = a \cosh^{-1} \left[ \frac{1 - x^1 X^1 - x^2 X^2}{\sqrt{1 - (x^1)^2 - (x^2)^2} \sqrt{1 - (X^1)^2 - (X^2)^2}} \right], \quad (1.2)$$

where  $a$  is a lengthscale. This space is infinite, because  $d(x, X) \rightarrow \infty$  when  $(X^1)^2 + (X^2)^2 \rightarrow 1$ . The logical independence of Euclidean's fifth postulate was thus established.

In 1827 Gauss published the *Disquisitiones generales circa superficies curvas*, where for the first time he distinguished the **inner**, or **intrinsic** properties of a surface from the **outer**, or **extrinsic** properties. The first are those properties that can be measured by somebody living on the surface. The second are those properties deriving from embedding the surface in a higher-dimensional space. Gauss realized that the fundamental inner property is the distance between two points, defined as the shortest path between them on the surface.

For example a cone or a cylinder have the same inner properties of a plane. The reason is that they can be obtained by a flat piece of paper suitably rolled, without distorting metric relations, i.e. without stretching or tearing. This means that the distance between any two points on the surface is the same as it was in the original piece of paper, and parallel lines remain parallel. Thus the **intrinsic geometry** of a cylinder or a cone is flat. This is not true in the case of a sphere, since a sphere cannot be mapped onto a plane without distortions: the inner properties of a sphere are different from those of a plane. It should be stressed that the intrinsic geometry of a surface considers only the relations between points on the surface.

However, since a cylinder or a cone are round in one direction, we think they are curved surfaces. This is due to the fact that we consider them as 2-dimensional surfaces in a 3-dimensional space, and we intuitively compare the curvature of the lines that stay on them with straight lines in the flat 3-dimensional space. Thus the extrinsic curvature relies on the notion of higher dimensional space. In the following, we shall be concerned only with the intrinsic properties of surfaces.

The distance between two points can be defined in a variety of ways, and consequently we can construct different metric spaces. Following Gauss, we shall select those metric spaces for which, given any sufficiently small region of space, it is possible to choose a system of coordinates  $(\xi^1, \xi^2)$  such that the *distance* between a point  $P = (\xi^1, \xi^2)$ , and the point  $P'(\xi^1 + d\xi^1, \xi^2 + d\xi^2)$  satisfies Pythagoras' law

$$ds^2 = (d\xi^1)^2 + (d\xi^2)^2. \quad (1.3)$$

From now on, when we say the *distance* between two points, we mean the distance between two points that are infinitely close.

This property, i.e. the possibility of setting up a locally euclidean coordinate system, is a **local** property: it deals only with the inner metric relations for infinitesimal neighborhoods. Thus, unless the space is globally euclidean, the coordinates  $(\xi_1, \xi_2)$  have only a local meaning. Let us now consider some other coordinate system  $(x_1, x_2)$  that *does* cover the space. How do we express the *distance* between two points? If we explicitly evaluate  $d\xi^1$  and  $d\xi^2$  in terms of the new coordinates we find

$$\begin{aligned} \xi^1 = \xi^1(x^1, x^2) &\quad \rightarrow d\xi^1 = \frac{\partial \xi^1}{\partial x^1} dx^1 + \frac{\partial \xi^1}{\partial x^2} dx^2 \\ \xi^2 = \xi^2(x^1, x^2) &\quad \rightarrow d\xi^2 = \frac{\partial \xi^2}{\partial x^1} dx^1 + \frac{\partial \xi^2}{\partial x^2} dx^2 \end{aligned} \quad (1.4)$$

$$\begin{aligned} ds^2 &= \left[ \left( \frac{\partial \xi^1}{\partial x^1} \right)^2 + \left( \frac{\partial \xi^2}{\partial x^1} \right)^2 \right] (dx^1)^2 + \left[ \left( \frac{\partial \xi^1}{\partial x^2} \right)^2 + \left( \frac{\partial \xi^2}{\partial x^2} \right)^2 \right] (dx^2)^2 \\ &+ 2 \left[ \left( \frac{\partial \xi^1}{\partial x^1} \right) \left( \frac{\partial \xi^1}{\partial x^2} \right) + \left( \frac{\partial \xi^2}{\partial x^1} \right) \left( \frac{\partial \xi^2}{\partial x^2} \right) \right] dx^1 dx^2 \\ &= g_{11} (dx^1)^2 + g_{22} (dx^2)^2 + 2g_{12} dx^1 dx^2 = g_{\alpha\beta} dx^\alpha dx^\beta. \end{aligned} \quad (1.5)$$

In the last line of eq. (1.5) we have defined the following quantities:

$$\begin{aligned} g_{11} &= \left[ \left( \frac{\partial \xi^1}{\partial x^1} \right)^2 + \left( \frac{\partial \xi^2}{\partial x^1} \right)^2 \right] \\ g_{22} &= \left[ \left( \frac{\partial \xi^1}{\partial x^2} \right)^2 + \left( \frac{\partial \xi^2}{\partial x^2} \right)^2 \right] \\ g_{12} &= \left[ \left( \frac{\partial \xi^1}{\partial x^1} \right) \left( \frac{\partial \xi^1}{\partial x^2} \right) + \left( \frac{\partial \xi^2}{\partial x^1} \right) \left( \frac{\partial \xi^2}{\partial x^2} \right) \right], \end{aligned} \quad (1.6)$$

namely, we have defined the metric tensor  $g_{\alpha\beta}$  ! i.e. the metric tensor is an object that allows us to compute the *distance* in any coordinate system. As it is clear from the preceding equations,  $g_{\alpha\beta}$  is a symmetric tensor, ( $g_{\alpha\beta} = g_{\beta\alpha}$ ). *In this way the notion of metric associated to a space, emerges in a natural way.*

EINSTEIN'S CONVENTION

In writing the last line of eq. (1.5) we have adopted the convention that if there is a product of two quantities having the same index appearing once in the lower and once in the upper case (“dummy indices”), then a summation is implied. For example, if the index  $\alpha$  takes the values 1 and 2

$$v_\alpha V^\alpha = \sum_{i=1}^2 v_i V^i = v_1 V^1 + v_2 V^2 \tag{1.7}$$

We shall adopt this convention in the following.

\*\*\*\*\*

EXAMPLE: HOW TO COMPUTE  $g_{\mu\nu}$

Given the locally euclidean coordinate system  $(\xi_1, \xi_2)$  let us introduce polar coordinates  $(r, \theta) = (x_1, x_2)$  . Then

$$\xi_1 = r \cos \theta \quad \rightarrow \quad d\xi^1 = \cos \theta dr - r \sin \theta d\theta \tag{1.8}$$

$$\xi_2 = r \sin \theta \quad \rightarrow \quad d\xi^2 = \sin \theta dr + r \cos \theta d\theta \tag{1.9}$$

$$ds^2 = (d\xi^1)^2 + (d\xi^2)^2 = dr^2 + r^2 d\theta^2, \tag{1.10}$$

and therefore

$$g_{11} = 1, \quad g_{22} = r^2, \quad g_{12} = 0. \tag{1.11}$$

\*\*\*\*\*

## 1.2 How does the metric tensor transform if we change the coordinate system

We shall now see how the metric tensor transforms under an arbitrary coordinate transformation. Let us suppose that we know  $g_{\alpha\beta}$  expressed in terms of the coordinate  $(x^1, x^2)$  , and we want to change the reference to a new system  $(x^1, x^2)$  . We have seen in section 1 that, for example, the component  $g_{11}$  is defined as

$$g_{11} = [(\frac{\partial \xi^1}{\partial x^1})^2 + (\frac{\partial \xi^2}{\partial x^1})^2], \tag{1.12}$$

where  $(\xi^1, \xi^2)$  are the coordinates of the locally euclidean reference frame, and  $(x^1, x^2)$  two arbitrary new coordinates. If we now put  $x^1 = x^1(x^1, x^2)$  , and  $x^2 = x^2(x^1, x^2)$  ,

the metric tensor in the new coordinate frame  $(x^{1'}, x^{2'})$  will be

$$\begin{aligned}
 g'_{11} \equiv g_{1'1'} &= \left[ \left( \frac{\partial \xi^1}{\partial x^{1'}} \right)^2 + \left( \frac{\partial \xi^2}{\partial x^{1'}} \right)^2 \right] \\
 &= \left[ \left( \frac{\partial \xi^1}{\partial x^1} \frac{\partial x^1}{\partial x^{1'}} + \frac{\partial \xi^1}{\partial x^2} \frac{\partial x^2}{\partial x^{1'}} \right)^2 + \left( \frac{\partial \xi^2}{\partial x^1} \frac{\partial x^1}{\partial x^{1'}} + \frac{\partial \xi^2}{\partial x^2} \frac{\partial x^2}{\partial x^{1'}} \right)^2 \right] \\
 &= \left[ \left( \frac{\partial \xi^1}{\partial x^1} \right)^2 + \left( \frac{\partial \xi^2}{\partial x^1} \right)^2 \right] \left( \frac{\partial x^1}{\partial x^{1'}} \right)^2 + \left[ \left( \frac{\partial \xi^1}{\partial x^2} \right)^2 + \left( \frac{\partial \xi^2}{\partial x^2} \right)^2 \right] \left( \frac{\partial x^2}{\partial x^{1'}} \right)^2 \\
 &+ 2 \left( \frac{\partial \xi^1}{\partial x^1} \frac{\partial \xi^1}{\partial x^2} + \frac{\partial \xi^2}{\partial x^1} \frac{\partial \xi^2}{\partial x^2} \right) \left( \frac{\partial x^1}{\partial x^{1'}} \frac{\partial x^2}{\partial x^{1'}} \right) \\
 &= g_{11} \left( \frac{\partial x^1}{\partial x^{1'}} \right)^2 + g_{22} \left( \frac{\partial x^2}{\partial x^{1'}} \right)^2 + 2g_{12} \left( \frac{\partial x^1}{\partial x^{1'}} \frac{\partial x^2}{\partial x^{1'}} \right).
 \end{aligned}
 \tag{1.13}$$

In general we can write

$$g'_{\alpha\beta} = g_{\mu\nu} \frac{\partial x^\mu}{\partial x^{\alpha'}} \frac{\partial x^\nu}{\partial x^{\beta'}} \tag{1.14}$$

This is the manner in which tensors transform under an arbitrary coordinate transformation (This point will be illustrated in more detail in following lectures).

\*\*\*\*\*

Thus, given a space in which the *distance* can be expressed in terms of Pythagoras' law, if we make an arbitrary coordinate transformation the knowledge of  $g_{\mu\nu}$  allows us to express the *distance* in the new reference system. The converse is also true: given a space in which

$$ds^2 = g_{\alpha\beta} dx^\alpha dx^\beta, \tag{1.15}$$

if this space belongs to the class defined by Gauss, at any given point it is always possible to choose a locally euclidean coordinate system  $(\xi_\alpha)$  such that

$$ds^2 = (d\xi^1)^2 + (d\xi^2)^2. \tag{1.16}$$

This concept can be generalized to a space of arbitrary dimensions.

**The metric determines the intrinsic properties of a metric space.**

We now want to define a function of  $g_{\alpha\beta}$  and of its first and second derivatives that depends on the inner properties of the surface, but does not depend on the particular coordinate system we may choose. Gauss showed that in the case of two-dimensional surfaces this function can be determined, and it is called, after him, the *gaussian curvature*, defined as

$$\begin{aligned}
 k(x^1, x^2) &= \frac{1}{2g} \left[ 2 \frac{\partial^2 g_{12}}{\partial x^1 \partial x^2} - \frac{\partial^2 g_{11}}{\partial x^2} - \frac{\partial^2 g_{22}}{\partial x^1} \right] \\
 &- \frac{g_{22}}{4g^2} \left[ \left( \frac{\partial g_{11}}{\partial x^1} \right) \left( 2 \frac{\partial g_{12}}{\partial x^2} - \frac{\partial g_{22}}{\partial x^1} \right) - \left( \frac{\partial g_{11}}{\partial x^2} \right)^2 \right] \\
 &+ \frac{g_{12}}{4g^2} \left[ \left( \frac{\partial g_{11}}{\partial x^1} \right) \left( \frac{\partial g_{22}}{\partial x^2} \right) - 2 \left( \frac{\partial g_{11}}{\partial x^2} \right) \left( \frac{\partial g_{22}}{\partial x^1} \right) \right. \\
 &\quad \left. + \left( 2 \frac{\partial g_{12}}{\partial x^1} - \frac{\partial g_{11}}{\partial x^2} \right) \left( 2 \frac{\partial g_{12}}{\partial x^2} - \frac{\partial g_{22}}{\partial x^1} \right) \right]
 \end{aligned}
 \tag{1.17}$$

$$-\frac{g_{11}}{4g^2} \left[ \left( \frac{\partial g_{22}}{\partial x^2} \right) \left( 2 \frac{\partial g_{12}}{\partial x^1} - \frac{\partial g_{11}}{\partial x^2} \right) - \left( \frac{\partial g_{22}}{\partial x^1} \right)^2 \right]$$

where  $g$  is the determinant of the 2-metric  $g_{\alpha\beta}$

$$g = g_{11}g_{22} - g_{12}^2. \quad (1.18)$$

For example, given a spherical surface, no matter how do we choose the coordinates, we shall always find that

$$k = \frac{1}{a^2}, \quad (1.19)$$

(try for example a sphere in polar coordinates  $ds^2 = a^2 d\theta^2 + a^2 \sin^2 \theta d\varphi^2$ , where  $a$  is the radius), or, for the Gauss-Bolyai-Lobachewski geometry where

$$g_{11} = \frac{a^2(1-x_2^2)}{(1-x_1^2-x_2^2)^2}, \quad g_{22} = \frac{a^2(1-x_1^2)}{(1-x_1^2-x_2^2)^2}, \quad g_{12} = \frac{a^2 x_1 x_2}{(1-x_1^2-x_2^2)^2}, \quad (1.20)$$

we shall always find

$$k = -\frac{1}{a^2}, \quad (1.21)$$

or, if the space is flat,  $k = 0$ . If we choose a different coordinate system,  $g_{\alpha\beta}(x_1, x_2)$  will change but  $k$  will remain the same.

### 1.3 Summary

We have seen that it is possible to select a class of 2-dimensional spaces where it is possible to set up, in the neighborhoods of any point, a coordinate system  $(\xi_1, \xi_2)$  such that the *distance* between two close points is given by Pythagoras' law. Then we have defined the metric tensor  $g_{\alpha\beta}$  which allows to compute the *distance* in an arbitrary coordinate system, and we have derived the law according to which  $g_{\alpha\beta}$  transforms when we change reference. Finally, we have shown that there exists a scalar quantity expressing the inner properties of a surface that is a function of  $g_{\alpha\beta}$  and its first and second derivatives, i.e. the gaussian curvature, that it is invariant under a coordinate transformation.

These results can be extended to an arbitrary D-dimensional space. In particular, as we shall understand better in the following, we are interested in the case D=4, and we shall select those spaces, or better, those spacetimes, for which the *distance* is that prescribed by Special Relativity.

$$ds^2 = -(d\xi^0)^2 + (d\xi^1)^2 + (d\xi^2)^2 + (d\xi^3)^2. \quad (1.22)$$

For the time being, let us only clarify the following point. In a D-dimensional space we need more than one function to describe the inner properties of a surface. Indeed, since  $g_{ij}$  is symmetric, there are only  $D(D+1)/2$  independent components. In addition, we can

choose  $D$  arbitrary coordinates, and impose  $D$  functional relations among them. Therefore the number of independent functions that describe the inner properties of the space will be

$$C = \frac{D(D+1)}{2} - D = \frac{D(D-1)}{2}. \quad (1.23)$$

If  $D=2$ , as we have seen  $C=1$ . If  $D=4$ ,  $C=6$ , therefore there will be 6 invariants to be constructed in our 4-dimensional spacetime. The problem of finding these invariant quantities was solved by Riemann (1826-1866) and subsequently developed by Christoffel, LeviCivita, Ricci, Beltrami. We shall see in the following that Riemannian geometries play a crucial role in the description of the gravitational field.

## 1.4 The newtonian theory

In this section we shall understand why the newtonian theory of gravity became unappropriate to correctly describe the gravitational field. The newtonian theory of gravity was published in 1685 in the “Philosophiae Naturalis Principia Mathematica”. They contain an incredible variety of fundamental results, and among them, the corner stones of classical physics:

1) *Newton’s law*

$$\vec{F} = m_I \vec{a}, \quad (1.24)$$

2) *Newton’s law of gravitation*

$$\vec{F}_G = m_G \vec{g}, \quad (1.25)$$

where

$$\vec{g} = -\frac{G \sum_i M_{G_i} (\vec{r} - \vec{r}_i')}{|\vec{r} - \vec{r}_i'|^3} \quad (1.26)$$

depends on the position of the massive particle with respect to the other masses that generate the field, and it decreases as the inverse square of the distance  $g \sim \frac{1}{r^2}$ . The two laws combined together clearly show that a body falls with an acceleration given by

$$\vec{a} = \left( \frac{m_G}{m_I} \right) \vec{g}. \quad (1.27)$$

If  $\frac{m_G}{m_I}$  is a constant independent on the body, the acceleration of falling bodies is the same for every body and independent on their mass. Galileo (1564-1642) had already experimentally discovered that this is true indeed. Newton itself tested the equivalence principle studying the motion of pendulum of different composition and equal length, and he found no difference in their periods. The validity of the equivalence principle was the core of Newton’s arguments for the universality of his law of gravitation. After describing his experiments with different pendulum in the Principia he says:

*But, without all doubt, the nature of gravity towards the planets is the same as towards the earth.*

I do not know if you have ever appreciated the big conceptual step that is implied in this sentence.

Since then a variety of experiments confirmed this crucial result. Among them Eotvos experiment in 1889 (accuracy of 1 part in  $10^9$ ), and Dicke experiment in 1964 (1 part in  $10^{11}$ ), and Braginsky in 1972 (1 part in  $10^{12}$ ). All the experiments up to our days confirm *The Principle of Equivalence of the gravitational and the inertial mass*. Now before describing why at a certain point the newtonian theory fails to be a satisfactory description of gravity, let me describe briefly the reasons of his success, that remained untouched for more than 200 years.

The monumental construction of the Principia is based on the newtonian law of gravitation. The theory of lunar motion and tides, the description of the planetary motion around the sun are the most elegant and accomplished description of these phenomena. It is interesting to note that in the Principia, Newton does not write equations: he simply describes in words what we are now able to compute using his equations and the mathematical instrument of infinitesimal calculus he invented and developed.

After Newton, the law of gravitation was used to investigate in more detail the solar system, and its application in the study of the perturbations of the orbit of Uranus led, in 1846, Adams (England) and Le Verrier (France) to the prediction of the existence of Neptune. A few years later the discovery of Neptun was a triumph of Newton's theory.

However, already in 1845 Le Verrier had observed anomalies in the motion of Mercury. He found that the precession in the perihelium of  $35''/100years$  exceeded the value due to the perturbation introduced by the other planets according to Newton's theory. In 1882 Newcomb confirmed this discrepancy, giving a higher value, of  $43''/100year$ . In order to explain this effect, scientists developed models that predicted the existence of some interplanetary matter, and in 1896 Seelinger showed that an ellipsoidal distribution of matter surrounding the sun could explain the observed precession.

We know today that these models were wrong, and that the reason of the exceedingly high precession of the perihelium of Mercury has a relativistic origin.

In any event, we can say that the newtonian theory worked remarkably fine to explain planetary motion, but already in 1845 the suspect that something did not work perfectly had some experimental evidence.

Let us turn now to a more phylosophical aspect of the theory. The equations of newtonian mechanics are invariant under Galileo's transformation

$$\begin{aligned}\vec{x}' &= R_0\vec{x} + \vec{v}t + \vec{d}_0 \\ t' &= t + \tau\end{aligned}\tag{1.28}$$

where  $R_0$  is the orthogonal, constant matrix expressing how the second frame is rotated with respect to the first (its elements depend on the three Euler angles),  $\vec{v}$  is the relative velocity of the two frames, and  $\vec{d}_0$  the initial distance between the two origins. The ten parameters (3 Euler angles, 3 components for  $\vec{v}$  and  $\vec{d}$ , + the time shift  $\tau$ ) identify the Galileo group.

The invariance of the equations with respect to Galileo's transformations implies the existence of **inertial frames** in which the laws of mechanics hold. What then determines which reference frames are inertial frames? For Newton the answer is that there exists an

absolute space, and the result of the famous experiment of the rotating vessel is a proof of its existence <sup>1</sup>

Thus inertial frames are those in uniform relative motion with respect to the absolute space. However this idea was rejected by Leibniz who claimed that there is no philosophical need for such a notion, and the debate on this issue continued during the next centuries. One of the major opponents was Mach who argued that if the masses in the entire universe would rigidly rotate with respect to the vessel, the water surface would bend in exactly the same way as when the vessel was rotating with respect to them. This is because the inertia is a measure of the gravitational interaction between a body and the matter content of the rest of the Universe.

The problems I have described (the discrepancy in the advance of perihelium and the postulate absolute space) are however only small clouds: the newtonian theory remains *The* theory of gravity until the end of the nineteenth century. The big storm approaches with the formulation of the theory of electrodynamics presented by Maxwell in 1864. Maxwell's equations state that the velocity of light must be a universal constant. It was soon understood that these equations are not invariant under Galileo's transformations, because according to them if the velocity of light is  $c$  in a given coordinate system, it cannot be  $c$  in a second reference moving with respect to the first according to eqs. (1.28). To justify this discrepancy, Maxwell formulated the hypothesis that light does not really propagate in vacuum: electromagnetic waves are carried by a medium, the *luminiferous ether*, and the equations are invariant only with respect to a set of galilean inertial frames that are at rest with respect to the ether. However in 1887 Michelson and Morley showed that the velocity of light is the same, within 5km/s (today the accuracy is less than 1km/s), along the direction of the earth's orbital motion, and transverse to it. What could it be the explanation of this fact? Either the earth could be in quiet with respect to the ether, but this hypothesis was totally unsatisfactory: it would have been a coming back to an antropocentric picture of the world. Or simply the ether did not exist and one has to accept the fact that the speed of light is the same in any direction. This was of course the only reasonable explanation. But now the problem was to find the coordinate transformation with respect to which Maxwell's equations are invariant. The problem was solved by Einstein in 1905, who showed that Galileo's transformations had to be replaced by the Lorentz transformations

$$x'^{\alpha} = L^{\alpha}_{\gamma} x^{\gamma}, \quad (1.29)$$

where  $\gamma = (1 - \frac{v^2}{c^2})^{-\frac{1}{2}}$ , and

$$L^0_0 = \gamma, \quad L^0_j = L^j_0 = \frac{\gamma}{c} v_j, \quad L^i_j = \delta^i_j + \frac{\gamma - 1}{v^2} v_i v_j. \quad i, j = 1, 3 \quad (1.30)$$

and  $v^i$  are the components of the velocity of the boost.

---

<sup>1</sup>The vessel experiment: a vessel is filled with water and rotates with a given angular velocity about the symmetry axis. After some time the surface of the water assumes the typical shape of a paraboloid, being in equilibrium under the action of the gravity force, the centrifugal force and the forces of constraints. Now suppose that the masses in the entire universe would rigidly rotate with respect to the vessel at the same angular velocity: for Newton the surface of the water would not bend, and would remain at rest because the vessel is not moving with respect to the absolute space and therefore no centrifugal force acts on it.

As it was immediately realised, however, while Maxwell's equations were invariant with respect to Lorentz transformations, Newton's equations were not, and it started to become clear that one should face the problem of how to modify the equations of mechanics and gravity in such a way that they become invariant with respect to Lorentz transformations. It is at this point that Einstein made his fundamental observation.

## 1.5 The role of the Equivalence Principle in the formulation of the new theory of gravity

Let us consider the motion of a non relativistic particle subjected to arbitrary forces  $\vec{F}$  and moving in a gravitational field that is **constant** . According to newtonian mechanics, the equation of motion will be

$$(m_I) \frac{d^2 \vec{x}}{dt^2} = (m_G) \vec{g} + \sum_k \vec{F}_k \quad (1.31)$$

Let us now jump on an elevator that is freely falling in the same gravitational field, i.e. let us make the following coordinate transformation

$$\vec{x}' = \vec{x} - \frac{1}{2} \vec{g} t^2, \quad t' = t. \quad (1.32)$$

In this new reference eq. (1.31) becomes

$$(m_I) \left[ \frac{d^2 \vec{x}'}{dt^2} + \vec{g} \right] = (m_G) \vec{g} + \sum_k \vec{F}_k. \quad (1.33)$$

Since by the Equivalence Principle  $m_I = m_G$ , and since this is true for **any** particle, this equation becomes

$$(m_I) \frac{d^2 \vec{x}'}{dt^2} = \sum_k \vec{F}_k. \quad (1.34)$$

Compare eq. (1.31) and eq. (1.34). We understand that an observer  $O'$  who is in the elevator, i.e. in free fall in the gravitational field, sees the same laws of physics as the initial observer  $O$ , but he does not see the gravitational field. **This result follows from the equivalence, experimentally tested, of the inertial and the gravitational mass.** If  $m_I$  would be different from  $m_G$  , (or better, if their ratio would not be constant and the same for all bodies), this would not be true, because we could not simplify the term in  $\vec{g}$  in eq. (1.33)! It is also apparent that if  $\vec{g}$  would not be constant eq. (1.34) would contain additional terms containing the derivatives of  $\vec{g}$  . However we can always consider an interval of time so short that  $\vec{g}$  can be considered as constant and eq. (1.34) holds. Consider a particle at rest in this frame and not subjected to any other force. Under this assumption, according to eq. (1.34) it will remain at rest forever. Therefore we can define this reference as a **locally inertial frame**. If the gravitational field is constant and uniform everywhere the coordinate transformation (1.32) defines a locally inertial frame that will cover the whole spacetime. If this is not the case we can set up a locally inertial frame only in the neighbourhood of any given point.

The points discussed above are crucial to the theory of gravity, and deserve a further explanation. Gravity is distinguished from all other forces because all bodies, given the same initial velocity, follow the same trajectory in a gravitational field, regardless of their internal constitution. This is not the case, for example, for electromagnetic forces, which act on charged but not on neutral bodies, and in any event the trajectories of charged particles depend on the ratio between charge and mass which is not the same for all particles. Similarly, other forces, like the strong and weak interactions, affect different particles differently. It is this distinctive feature of gravity that makes it possible, as we shall see soon, to describe the effects of gravity in terms of curved geometry.

So let us now state the Principle of Equivalence. There are two formulations:

**The strong Principle of Equivalence**

*In an arbitrary gravitational field, at any given spacetime point, we can choose a locally inertial reference frame such that, in a sufficiently small region surrounding that point, all physical laws take the same form they would take in absence of gravity, namely the form prescribed by Special Relativity.*

There is also a weaker version of this principle

**The weak Principle of Equivalence**

*Same as before, but it refers to the laws of motion of freely falling bodies, instead of all physical laws.*

Now it is clear that the preceding formulation of the equivalence principle resembles very much to the axiom that Gauss chose as a basis for non-euclidean geometries: at any given point in space, there exist a locally euclidean reference frame such that, in a sufficiently small region surrounding that point, the *distance* between two points is given by the law of Pythagoras.

The Equivalence Principle states that in a locally inertial frame all laws of physics must coincide, locally, with those of Special Relativity, and consequently in this frame the *distance* between two points must coincide with the Minkowsky expression

$$ds^2 = -c^2 dt^2 + dx^2 + dy^2 + dz^2 = -(d\xi^0)^2 + (d\xi^1)^2 + (d\xi^2)^2 + (d\xi^3)^2. \quad (1.35)$$

We therefore expect that the equations of gravity will look very similar to those of Riemannian geometry. In particular, as Gauss defined the inner properties of curved surfaces in terms of the derivatives  $\frac{\partial \xi^\alpha}{\partial x^\mu}$  (which in turn defined the metric, see eq. (1.5) and (1.7)), where  $\xi^\alpha$  are the “locally euclidean coordinates” and  $x^\mu$  are arbitrary coordinates, in a similar way we expect that the effects of a gravitational field will be described in terms of the derivatives  $\frac{\partial \xi^\alpha}{\partial x^\mu}$  where now  $\xi^\alpha$  are the “locally inertial” coordinates, and  $x^\mu$  are arbitrary coordinates. All this will follow from the equivalence principle. Up to now we have only established that, by virtue of the Equivalence Principle there exist a connection between the gravitational field and the metric tensor. But which connection?

## 1.6 The geodesic equations as a consequence of the Principle of Equivalence

Let us start exploring what are the consequences of the Principle of Equivalence. We want to find the equation of motion for a particle that moves under the exclusive action of a

gravitational field (i.e. it is in free fall), when this motion is observed in an arbitrary reference frame.

We shall now work in a four-dimensional spacetime with coordinates  $(x^0 = ct, x^1, x^2, x^3)$ .

First we start analysing the motion in a locally inertial frame, for example the one in free fall with the particle. For the principle of Equivalence, in this frame the *distance* will be

$$ds^2 = -(dx^0)^2 + (dx^1)^2 + (dx^2)^2 + (dx^3)^2 = \eta_{\mu\nu} d\xi^\mu d\xi^\nu, \quad (1.36)$$

where  $\eta_{\mu\nu} = \text{diag}(-1, 1, 1, 1)$  is the metric tensor of the flat Minkowskian spacetime. If  $\tau$  is the time coordinate in this frame, i.e.  $\tau$  is the proper time of the particle, the equation of motion, for what we said before, are

$$\frac{d^2 \xi^\alpha}{d\tau^2} = 0. \quad (1.37)$$

We now change to a frame where the coordinates are labelled  $x^\alpha = x^\alpha(\xi^\alpha)$ . Thus we assign a law of transformation that allows us to express the new coordinates as functions of the old ones. In a following lecture we shall clarify and make rigorous all concepts that we are now using, such as metric tensor, coordinate transformations etc.

In the new frame the *distance* is

$$ds^2 = \eta_{\alpha\beta} \frac{\partial \xi^\alpha}{\partial x^\mu} dx^\mu \frac{\partial \xi^\beta}{\partial x^\nu} dx^\nu = g_{\mu\nu} dx^\mu dx^\nu, \quad (1.38)$$

where we have defined the metric tensor  $g_{\mu\nu}$  as

$$g_{\mu\nu} = \frac{\partial \xi^\alpha}{\partial x^\mu} \frac{\partial \xi^\beta}{\partial x^\nu} \eta_{\alpha\beta}. \quad (1.39)$$

This formula is the 4-dimensional generalization of the 2-dimensional gaussian formula (see eq. (1.5)). In the new frame the equation of motion of the particle (1.37) becomes:

$$\frac{d^2 x^\alpha}{d\tau^2} + \left[ \frac{\partial x^\alpha}{\partial \xi^\lambda} \frac{\partial^2 \xi^\lambda}{\partial x^\mu \partial x^\nu} \right] \left[ \frac{dx^\mu}{d\tau} \frac{dx^\nu}{d\tau} \right] = 0. \quad (1.40)$$

(see the detailed calculations in appendix A). If we now define the following quantities

$$\Gamma_{\mu\nu}^\alpha = \frac{\partial x^\alpha}{\partial \xi^\lambda} \frac{\partial^2 \xi^\lambda}{\partial x^\mu \partial x^\nu}, \quad (1.41)$$

eq. (1.40) become

$$\frac{d^2 x^\alpha}{d\tau^2} + \Gamma_{\mu\nu}^\alpha \left[ \frac{dx^\mu}{d\tau} \frac{dx^\nu}{d\tau} \right] = 0. \quad (1.42)$$

The quantities (1.41) are called the **affine connections**, or the **Christoffel symbols**, whose properties we shall investigate in a following lecture. Equation (1.42) is the **geodesic equation**, the equation of motion of a freely falling particle when observed in an arbitrary coordinate frame. Let us analyse this equation. We have seen that if we are in a locally inertial frame, where, by virtue of Equivalence Principle, we are able to eliminate the gravitational force, the equations of motion would be that of a free particle (eq. 1.37). If we

change to another frame we shall see the gravitational field (and in addition all apparent forces like centrifugal, Coriolis, and dragging forces). In this new frame the geodesic equation becomes eq. (1.42) and the additional term

$$\Gamma_{\mu\nu}^{\alpha} \left[ \frac{dx^{\mu}}{d\tau} \frac{dx^{\nu}}{d\tau} \right] \quad (1.43)$$

expresses the gravitational force per unit mass that acts on the particle. If we were in newtonian mechanics, this term would be  $\vec{g}$  (plus the additional apparent accelerations, but let us assume for the time being that we choose a reference where they vanish), i.e. the derivative of the gravitational potential. What does that mean? The affine connection  $\Gamma_{\mu\nu}^{\alpha}$  contains the second derivatives of  $(\xi^{\alpha})$ . Since the metric tensor (1.39) contains the first derivatives of  $(\xi^{\alpha})$  (see eq. (1.39)), it is clear that  $\Gamma_{\mu\nu}^{\alpha}$  will contain first derivatives of  $g_{\mu\nu}$ . This can be shown explicitly, and we shall show that this is indeed the case in a next lecture. The result will be

$$\Gamma_{\lambda\mu}^{\sigma} = \frac{1}{2} g^{\nu\sigma} \left\{ \frac{\partial g_{\mu\nu}}{\partial x^{\lambda}} + \frac{\partial g_{\lambda\nu}}{\partial x^{\mu}} - \frac{\partial g_{\lambda\mu}}{\partial x^{\nu}} \right\}. \quad (1.44)$$

**Thus, in analogy with the newtonian law, we can say that the affine connections are the generalization of the newtonian gravitational field, and that the metric tensor is the generalization of the newtonian gravitational potential.**

I would like to stress that this is a *physical* analogy, based on the study of the motion of freely falling particles compared with the newtonian equations of motion.

## 1.7 Summary

We have seen that once we introduce the Principle of Equivalence, the notion of metric and affine connections emerge in a natural way to describe the effects of a gravitational field on the motion of falling bodies. It should be stressed that the metric tensor  $g_{\mu\nu}$  represents the gravitational potential, as it follows from the geodesic equations. But in addition it is a geometrical entity, since, through the notion of *distance*, it characterizes the spacetime geometry. This double role, physical and geometrical of the metric tensor, is a direct consequence of the Principle of Equivalence, as I hope it is now clear.

Now we can answer the question “why do we need a tensor to describe a gravitational field”: the answer is in the Equivalence Principle.

## 1.8 Locally inertial frames

We shall now show that if we know  $g_{\mu\nu}$  and  $\Gamma_{\mu\nu}^{\alpha}$  (i.e.  $g_{\mu\nu}$  and its first derivatives) at a point  $X$ , we can determine a locally inertial frame  $\xi^{\alpha}(x)$  in the neighborhood of  $X$  in the following way. Multiply  $\Gamma_{\mu\nu}^{\beta}$  by  $\frac{\partial \xi^{\beta}}{\partial x^{\lambda}}$

$$\begin{aligned} \frac{\partial \xi^\beta}{\partial x^\lambda} \Gamma_{\mu\nu}^\lambda &= \frac{\partial \xi^\beta}{\partial x^\lambda} \frac{\partial x^\lambda}{\partial \xi^\alpha} \frac{\partial^2 \xi^\alpha}{\partial x^\mu \partial x^\nu} = \\ &\delta_\alpha^\beta \frac{\partial^2 \xi^\alpha}{\partial x^\mu \partial x^\nu} = \frac{\partial^2 \xi^\beta}{\partial x^\mu \partial x^\nu}, \end{aligned} \quad (1.45)$$

i.e.

$$\frac{\partial^2 \xi^\beta}{\partial x^\mu \partial x^\nu} = \frac{\partial \xi^\beta}{\partial x^\lambda} \Gamma_{\mu\nu}^\lambda. \quad (1.46)$$

This equation can be solved by a series expansion near  $X$

$$\begin{aligned} \xi^\beta(x) &= \xi^\beta(X) + \left[ \frac{\partial \xi^\beta(x)}{\partial x^\lambda} \right]_{x=X} (x^\lambda - X^\lambda) \\ &+ \frac{1}{2} \left[ \frac{\partial \xi^\beta(x)}{\partial x^\lambda} \Gamma_{\mu\nu}^\lambda \right]_{x=X} (x^\mu - X^\mu)(x^\nu - X^\nu) + \dots \\ &= a^\beta + b_\lambda^\beta (x^\lambda - X^\lambda) + \frac{1}{2} b_\lambda^\beta \Gamma_{\mu\nu}^\lambda (x^\mu - X^\mu)(x^\nu - X^\nu) + \dots \end{aligned} \quad (1.47)$$

On the other hand we know by eq. (1.39) that

$$g_{\mu\nu}(X) = \eta_{\alpha\beta} \frac{\partial \xi^\alpha(x)}{\partial x^\mu} \Big|_{x=X} \frac{\partial \xi^\beta(x)}{\partial x^\nu} \Big|_{x=X} = \eta_{\alpha\beta} b_\mu^\alpha b_\nu^\beta, \quad (1.48)$$

and from this equation we compute  $b_\mu^\beta$ . Thus, given  $g_{\mu\nu}$  and  $\Gamma_{\mu\nu}^\alpha$  at a given point  $X$  we can determine the local inertial frame to order  $(x - X)^2$  by using eq. (1.47). This equation defines the coordinate system except for the ambiguity in the constants  $a^\mu$ . In addition we have still the freedom to make an inhomogeneous Lorentz transformation, and the new frame will still be locally inertial, as it is shown in appendix B.

## 1.9 Appendix 1A

Given the equation of motion of a free particle

$$\frac{d^2 \xi^\alpha}{d\tau^2} = 0, \quad (A1)$$

let us make a coordinate transformation to an arbitrary system  $x^\alpha$

$$\xi^\alpha = \xi^\alpha(x^\gamma), \quad \rightarrow \quad \frac{d\xi^\alpha}{d\tau} = \frac{\partial \xi^\alpha}{\partial x^\gamma} \frac{dx^\gamma}{d\tau}, \quad (A2)$$

eq. (A1) becomes

$$\frac{d}{d\tau} \left( \frac{\partial \xi^\alpha}{\partial x^\gamma} \frac{dx^\gamma}{d\tau} \right) = \frac{d^2 x^\gamma}{d\tau^2} \frac{\partial \xi^\alpha}{\partial x^\gamma} + \frac{\partial^2 \xi^\alpha}{\partial x^\beta \partial x^\gamma} \frac{dx^\beta}{d\tau} \frac{dx^\gamma}{d\tau} = 0. \quad (A3)$$

Multiply eq. (A3) by  $\frac{\partial x^\sigma}{\partial \xi^\alpha}$  remembering that

$$\frac{\partial \xi^\alpha}{\partial x^\gamma} \frac{\partial x^\sigma}{\partial \xi^\alpha} = \frac{\partial x^\sigma}{\partial x^\gamma} = \delta_\gamma^\sigma,$$

where  $\delta_\gamma^\sigma$  is the Kronecker symbol ( $= 1$  if  $\sigma = \gamma$   $0$  otherwise), we find

$$\frac{d^2 x^\gamma}{d\tau^2} \delta_\gamma^\sigma + \frac{\partial x^\sigma}{\partial \xi^\alpha} \frac{\partial^2 \xi^\alpha}{\partial x^\beta \partial x^\gamma} \frac{dx^\beta}{d\tau} \frac{dx^\gamma}{d\tau} = 0, \quad (A4)$$

which finally becomes

$$\frac{d^2 x^\sigma}{d\tau^2} + \left[ \frac{\partial x^\sigma}{\partial \xi^\alpha} \frac{\partial^2 \xi^\alpha}{\partial x^\beta \partial x^\gamma} \right] \frac{dx^\beta}{d\tau} \frac{dx^\gamma}{d\tau} = 0, \quad (A5)$$

which is eq. (1.40).

## 1.10 Appendix 1B

Given a locally inertial frame  $\xi^\alpha$

$$ds^2 = \eta_{\mu\nu} d\xi^\mu d\xi^\nu. \quad (B1)$$

let us consider the Lorentz transformation

$$\xi^i = L^i_{j'} \xi^{j'}, \quad (B2)$$

where

$$L_j^i = \delta_j^i + v^i v_j \frac{\gamma - 1}{v^2}, \quad L_j^0 = \frac{\gamma v_j}{c}, \quad L_0^0 = \gamma, \quad \gamma = \left(1 - \frac{v^2}{c^2}\right)^{-\frac{1}{2}}. \quad (B3)$$

The *distance* will now be

$$ds^2 = \eta_{\mu\nu} d\xi^\mu d\xi^\nu = \eta_{\mu\nu} \frac{\partial \xi^\mu}{\partial \xi^{i'}} \frac{\partial \xi^\nu}{\partial \xi^{j'}} d\xi^{i'} d\xi^{j'}.; \quad (B4)$$

Since

$$\frac{\partial \xi^\mu}{\partial \xi^{i'}} = L^\mu_{\beta} \delta^{\beta}_{i'} = L^\mu_{i'}, \quad (B5)$$

it follows that

$$ds^2 = \eta_{\mu\nu} L^\mu_{i'} L^\nu_{j'} d\xi^{i'} d\xi^{j'}. \quad (B6)$$

Since  $L_j^i$  is a Lorentz transformation,

$$\eta_{\mu\nu} L^\mu_{i'} L^\nu_{j'} = \eta_{i'j'},$$

consequently the new frame is still a locally inertial frame.

$$ds^2 = \eta_{\mu\nu'} d\xi^{\mu'} d\xi^{\nu'}. \quad (B7)$$

# Chapter 2

## Topological Spaces, Mapping, Manifolds

In chapter I we have shown that the Principle of Equivalence allows to establish a relation between the metric tensor and the gravitational field. We used vectors and tensor, we made coordinate transformations, but we did not define the geometrical objects we were introducing, and we did not discuss whether we are entitled to use these notions. We shall now define in a more rigorous way what is the type of space we are working in, what is a coordinate transformation, a vector, a tensor. Then we shall introduce the metric tensor and the affine connections as geometrical objects and, after defining the covariant derivative, we shall finally be able to introduce the Riemann tensor. This work is preliminary to the derivation of Einstein's equations.

### 2.1 Topological spaces

In general relativity we shall deal with *topological spaces*. The word topology has two distinct meanings: local topology (to which we are mainly interested), and global topology, which involves the study of the large scale features of a space, such those that distinguish a sphere from a cone. In order to define a topological space we need some preliminary definitions.

First of all, be  $\mathbf{R}^n$  the n-dimensional space of vector algebra: a point in  $\mathbf{R}^n$  is a sequence of real numbers  $(x^1, x^2, \dots, x^n)$ , also called an n-tuple of real numbers. Intuitively we have an idea that this is a **continuum space**, namely that there are points of  $\mathbf{R}^n$  arbitrarily close to any given point, that the line joining two points can be subdivided into arbitrarily many pieces which also join points of  $\mathbf{R}^n$ . A non continuous space is, for example, a lattice.

*Open Sets.* Given a point  $y = (y^1, y^2, \dots, y^n)$ , an open set is the collection of points  $x$  such that

$$|x - y| \equiv \sqrt{\sum_{i=1}^n (x^i - y^i)^2} < r, \quad (2.1)$$

where  $r$  is a real number. (This is sometimes called an 'open ball').

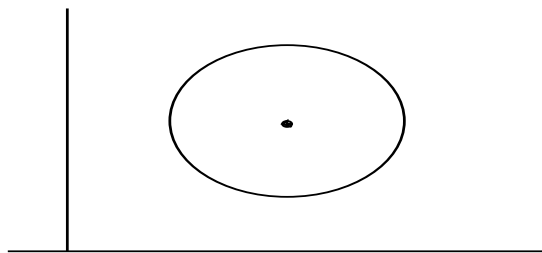

An open set includes all points in the interior of the “ball”, *but not on the boundary*.

A set of points  $\mathbf{S}$  is open if every point  $x \in \mathbf{S}$  has a neighborhood entirely contained in  $\mathbf{S}$ . Thus if in the definition of open sets we had included the boundary

$$|x - y| \leq r, \quad (2.2)$$

there would exist points in  $\mathbf{S}$  (those on the boundary) that do not satisfy the previous property. The idea that a line connecting two points can be indefinitely subdivided, is related to the so-called *Hausdorff property* of  $\mathbf{R}^n$ , i.e.: any two points of  $\mathbf{R}^n$  have neighborhoods which do not intersect

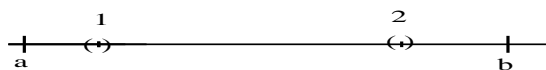

We can now define open sets of  $\mathbf{R}^n$  which satisfy the following properties

- 1) if  $\mathbf{O}_1$  and  $\mathbf{O}_2$  are open sets, so is their intersection.
- 2) the union of any collection (possibly infinite in number) of open sets is open.

A topological space is a collection of points that satisfies (1) and (2).

## 2.2 Mapping

A map  $f$  from a space  $\mathbf{M}$  to a space  $\mathbf{N}$  is a rule which associates with an element  $x$  of  $\mathbf{M}$ , a unique element  $y = f(x)$  of  $\mathbf{N}$

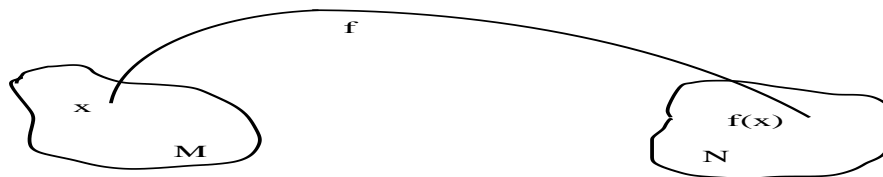

$\mathbf{M}$  and  $\mathbf{N}$  need not to be different. For example, the simplest maps are ordinary real-valued functions on  $\mathbf{R}$

EXAMPLE  $y = x^3, \quad x \in \mathbf{R}, \quad \text{and} \quad y \in \mathbf{R}. \quad (2.3)$

In this case  $\mathbf{M}$  and  $\mathbf{N}$  coincide.

A map gives a unique  $f(x)$  for every  $x$ , but not necessarily a unique  $x$  for every  $f(x)$ .  
EXAMPLE

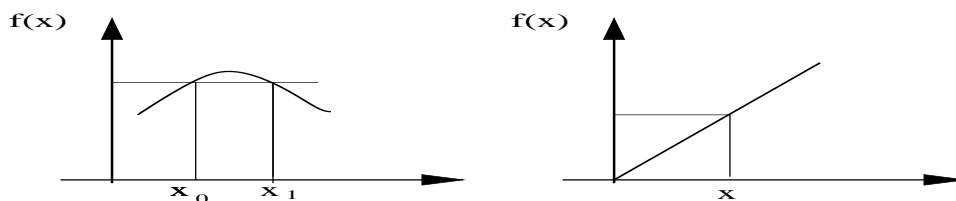

map **many to one**

map **one to one**

If  $f$  maps  $\mathbf{M}$  to  $\mathbf{N}$  then for any set  $\mathbf{S}$  in  $\mathbf{M}$  we have an *image* in  $\mathbf{N}$ , i.e. the set  $\mathbf{T}$  of all points mapped by  $f$  from  $\mathbf{S}$  in  $\mathbf{N}$

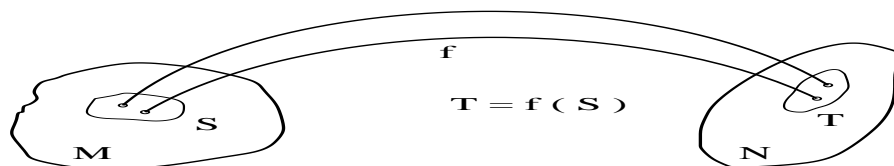

Conversely the set  $\mathbf{S}$  is the *inverse image* of  $\mathbf{T}$

$$\mathbf{S} = f^{-1}(\mathbf{T}). \quad (2.4)$$

Inverse mapping is possible only in the case of one-to-one mapping. The statement “ $f$  maps  $\mathbf{M}$  to  $\mathbf{N}$ ” is indicated as

$$f : \mathbf{M} \rightarrow \mathbf{N}. \quad (2.5)$$

$f$  maps a particular element  $x \in \mathbf{M}$  to  $y \in \mathbf{N}$  is indicated as

$$f : x \mapsto y \quad (2.6)$$

the image of a point  $x$  is  $f(x)$ .

### 2.3 Composition of maps

Given two maps  $f : M \rightarrow N$  and  $g : N \rightarrow P$ , there exists a map  $g \circ f$  that maps  $M$  to  $P$

$$g \circ f : M \rightarrow P. \tag{2.7}$$

This means: take a point  $x \in M$  and find the image  $f(x) \in N$ , then use  $g$  to map this point to a point  $g(f(x)) \in P$

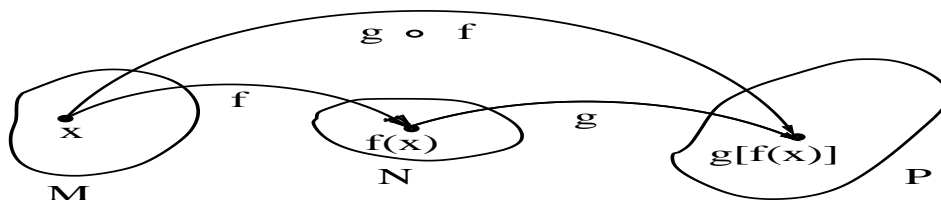

EXAMPLE

$$\begin{aligned}
 f : x & \mapsto y & y & = x^3 \\
 g : y & \mapsto z & z & = y^2 \\
 g \circ f : x & \mapsto z & z & = x^6
 \end{aligned}
 \tag{2.8}$$

**Map into:** If a map is defined for all points of a manifold  $M$ , it is a mapping from  $M$  into  $N$ .

**Map onto:** If, in addition, every point of  $N$  has an inverse image (but not necessarily a unique one), it is a map from  $M$  onto  $N$ .

EXAMPLE: be  $N$  the unit open disc in  $\mathbf{R}^2$ , i.e. the set of all points in  $\mathbf{R}^2$  such that the distance from the center is less than one,  $d(0, x) < 1$ . Be  $M$  the surface of an hemisphere  $\theta < \frac{\pi}{2}$  belonging to the unit sphere.

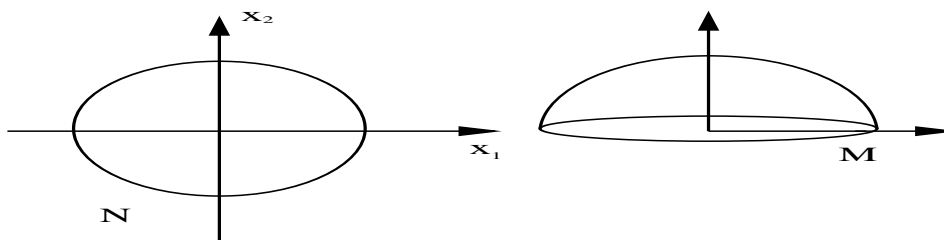

There exists a one-to one mapping  $f$  from  $M$  onto  $N$ .

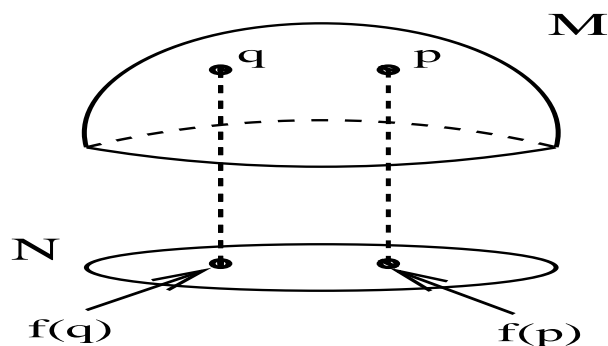

## 2.4 Continuous mapping

A map  $f : M \rightarrow N$  is continuous at  $x \in M$  if any open set of  $N$  containing  $f(x)$  contains the image of an open set of  $M$ .  $M$  and  $N$  must be topological spaces, otherwise the notion of continuity has no meaning.

This definition is related to the familiar notion of continuous functions. Suppose that  $f$  is a real-valued function of one real variable. That is  $f$  is a map of  $\mathbf{R}$  to  $\mathbf{R}$

$$f : \mathbf{R} \rightarrow \mathbf{R}. \quad (2.9)$$

In the elementary calculus we say that  $f$  is continuous at a point  $x_0$  if for every  $\epsilon > 0$  there exists a  $\delta > 0$  such that

$$|f(x) - f(x_0)| < \epsilon, \quad \forall x \text{ such that } |x - x_0| < \delta. \quad (2.10)$$

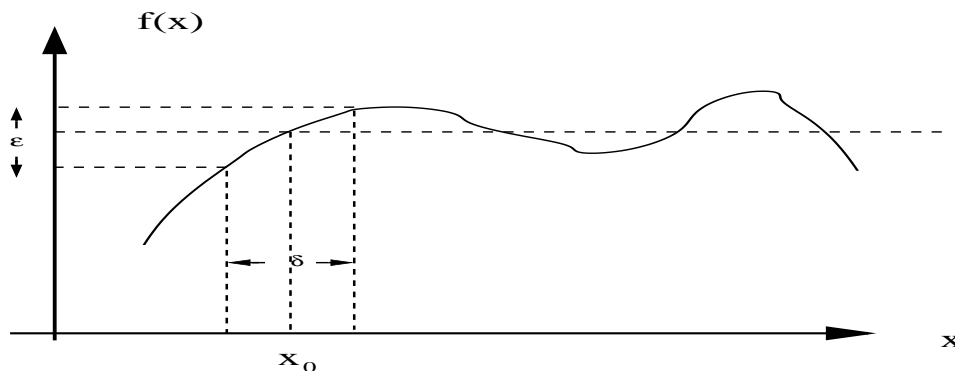

Let us translate this definition in terms of open sets. From the figure it is apparent that any open set containing  $f(x_0)$ , i.e.  $|f(x) - f(x_0)| < r$  with  $r$  arbitrary, contains an image of an open set of  $M$ . This is true at least in the domain of definition of  $f$ . This definition is more general than that of continuous functions, because we can choose  $\epsilon$  and  $\delta$  as big as we like, provided we remain in the domain of definition of  $f$ .

## 2.5 Differentiable mapping

Since we are dealing with maps of  $\mathbf{R}$  into  $\mathbf{R}$  (see previous figure) the notion of functions  $C^k$  familiar from elementary calculus applies: if  $f(x^1, x^2, \dots, x^n)$  is a function defined on some open region  $\mathbf{S}$  of  $\mathbf{R}^n$ , it is said to be *differentiable of class  $C^k$*  if all its partial derivatives of order less than or equal to  $k$  exist and are continuous functions on  $\mathbf{S}$ . For example a function  $C^0$  is only continuous, and  $C^\infty$  is a function such that all derivatives exist.

## 2.6 Manifolds

The notion of manifold is crucial to define a coordinate system.

*A manifold is a collection of points  $\mathbf{M}$  such that each point of  $\mathbf{M}$  has an open neighborhood which has a continuous 1-1 map onto an open set of  $\mathbf{R}^n$ .  $n$  is the dimension of the manifold.*

In this definition we have used the concepts defined in the preceding pages: the space must be topological, with no holes, i.e. continuous, and we want to associate an  $n$ -tuple of real numbers, i.e. *a set of coordinates* to each point. For example, when we consider the diagram

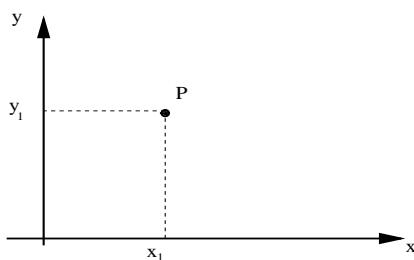

we are just using the notion of manifold: we take a point  $P$ , and map it to the point  $(x^1, y^1) \in \mathbf{R}^2$ . And this operation can be done for any open neighborhood of  $P$ . It should be stressed that the definition of manifold involves open sets and not the whole of  $\mathbf{M}$  and  $\mathbf{R}^n$ , because we do not want to restrict the global topology of  $\mathbf{M}$ . Moreover, at this stage we only require the map to be 1-1. We have not yet introduced any geometrical notion as length, angles etc. At this level we only require that the local topology of  $\mathbf{M}$  is the same as that of  $\mathbf{R}^n$ . *A manifold is a space with this topology.*

### DEFINITION OF COORDINATE SYSTEMS

A coordinate system, or a **chart**, is a pair consisting of an open set of  $\mathbf{M}$  and its map to an open set of  $\mathbf{R}^n$ . The open set does not necessarily include all  $\mathbf{M}$ , thus there will be other open sets with the associated maps, and each point of  $\mathbf{M}$  must lie in at least one of such open sets.

### AND NOW WE WANT TO MAKE A COORDINATE TRANSFORMATION.

Let us consider, for example, the following situation:  $\mathbf{U}$  and  $\mathbf{V}$  are two overlapping open sets of  $\mathbf{M}$  with two distinct maps onto  $\mathbf{R}^n$

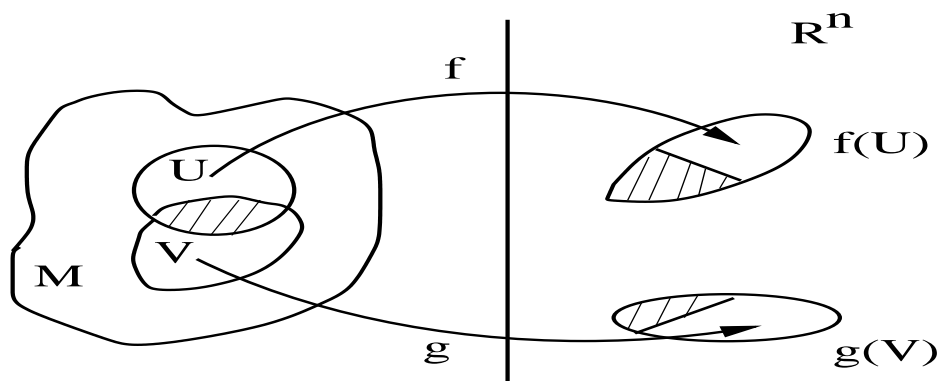

The overlapping region is open (since it is the intersection of two open sets), and is given two different coordinate systems by the two maps, thus there must exist some equation relating the two. We want to find it.

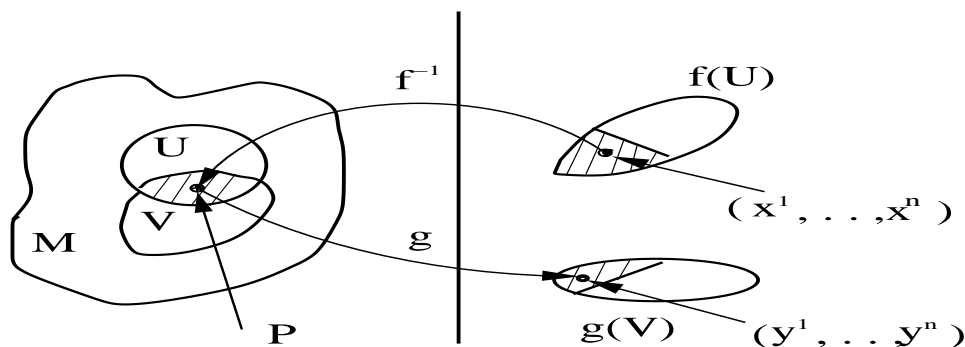

Pick a point in the image of the overlapping region belonging to  $f(U)$ , say the point  $(x^1, \dots, x^n)$ . The map  $f$  has an inverse  $f^{-1}$  which brings to the point  $P$ . Now from  $P$ , by using the map  $g$ , we go to the image of  $P$  belonging to  $g(V)$ , i.e. to the point  $(y^1, \dots, y^n)$  in  $\mathbb{R}^n$

$$g \circ f^{-1} : \mathbb{R}^n \rightarrow \mathbb{R}^n. \tag{2.11}$$

The result of this operation is a functional relation between the two sets of coordinates:

$$\begin{cases} y^1 = y^1(x^1, \dots, x^n) \\ \vdots \\ y^n = y^n(x^1, \dots, x^n), \end{cases} \tag{2.12}$$

If the partial derivatives of order  $\leq k$  of all the functions  $\{y^i\}$  with respect to all  $\{x^i\}$  exist and are continuous, then the charts  $(U, f)$  and  $(V, g)$  are said to be  $C^k$  related.

If it is possible to construct a system of charts such that each point of  $\mathbf{M}$  belongs at least to one of the open sets, and every chart is  $C^k$  related to every other one it overlaps with, then the manifold is said to be a  $C^k$  manifold. If  $k=1$ , it is called a *differentiable manifold*.

The notion of differentiable manifold is crucial, because it allows to add “structure” to the manifold, i.e. one can define vectors, tensors, differential forms, Lie derivatives etc.

In order to complete our definition of a coordinate transformation we still need another element. Eqs. (2.12) can be written as

$$y^i = f^i(x^1, \dots, x^n), \quad i = 1, \dots, n, \quad (2.13)$$

where  $f^i$  are  $C^k$  differentiable. Be  $\mathbf{J}$  the jacobian of the transformation

$$\mathbf{J} = \frac{\partial(f^1, \dots, f^n)}{\partial(x^1, \dots, x^n)} = \det \begin{pmatrix} \frac{\partial f^1}{\partial x^1} & \frac{\partial f^1}{\partial x^2} & \dots & \dots & \frac{\partial f^1}{\partial x^n} \\ \frac{\partial f^2}{\partial x^1} & \frac{\partial f^2}{\partial x^2} & \dots & \dots & \frac{\partial f^2}{\partial x^n} \\ \dots & \dots & \dots & \dots & \dots \\ \frac{\partial f^n}{\partial x^1} & \frac{\partial f^n}{\partial x^2} & \dots & \dots & \frac{\partial f^n}{\partial x^n} \end{pmatrix} \quad (2.14)$$

If  $\mathbf{J}$  is non zero at some point P, then the inverse function theorem ensures that the map  $f$  is 1-1 and **onto** in some neighborhood of P. If  $\mathbf{J}$  is zero at some point P the transformation is singular.

AN EXAMPLE OF MANIFOLD.

Consider the 2-sphere (also called  $\mathbf{S}^2$ ). It is defined as the set of all points in  $\mathbf{R}^3$  such that  $(x^1)^2 + (x^2)^2 + (x^3)^2 = \text{const}$ . Suppose that we want to map the *whole* sphere to  $\mathbf{R}^2$  by using a single chart. For example let us use spherical coordinates  $\theta \equiv x^1$ , and  $\varphi \equiv x^2$ . The sphere appears to be mapped onto the rectangle  $0 \leq x^1 \leq \pi$ ,  $0 \leq x^2 \leq 2\pi$

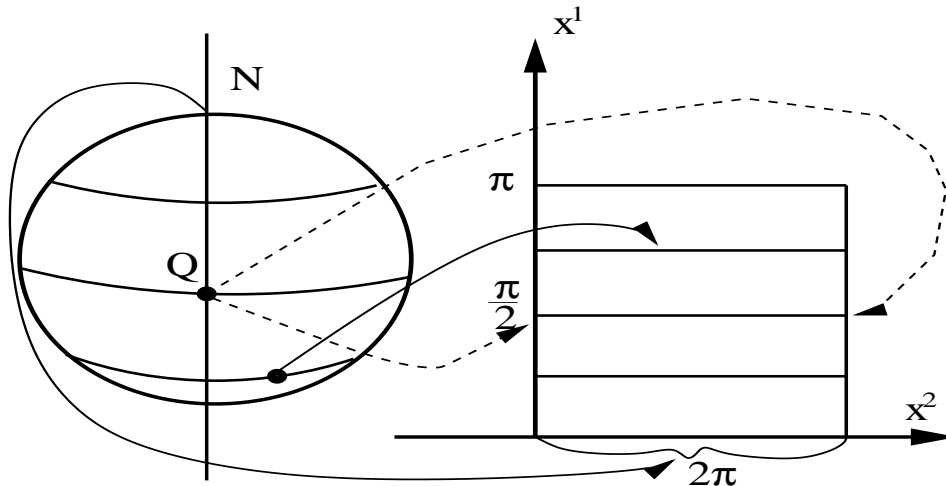

(note that this manifold has no boundary). But now consider the north pole  $\theta = 0$ : this point is mapped to the entire line

$$x^1 = 0, \quad 0 \leq x^2 \leq 2\pi. \quad (2.15)$$

*Thus there is no map at all.*

In addition all points of the emicircle  $\varphi = 0$  are mapped in two places

$$x^2 = 0, \quad \text{and} \quad x^2 = 2\pi. \quad (2.16)$$

*Again there is no map at all.* In order to avoid these problems, we must restrict the map to open regions

$$0 < x^1 < \pi, \quad 0 < x^2 < 2\pi. \quad (2.17)$$

The two poles and the semicircle  $\varphi = 0$  are left out. Then we may consider a second map, again in spherical coordinates but “rotated” in such a way that the line  $\varphi = 0$  would coincide with the equator of the old system. Then every point of the sphere would be covered by one of the two charts, and in principle one should be able to find the coordinate transformation for the overlapping region. It is interesting to note that

- 1) this mapping does not preserve angles and lengths.
- 2) there exist manifolds that cannot be covered by a single chart, i.e. by a single coordinate system.

# Chapter 3

## Vectors and One-forms

In what follows we shall consider a 2-dimensional space, but the concepts we shall introduce can immediately be generalized to higher dimensional spaces, and, in particular, to a 4-dimensional spacetime. Consider for example a 2-dimensional euclidean plane. We can choose any coordinate system we like, for example cartesian coordinates  $(x, y)$ , polar coordinates

$$\begin{cases} r = \sqrt{x^2 + y^2} \\ \theta = \arctan \frac{y}{x}, \end{cases} \quad \begin{cases} x = r \cos \theta \\ y = r \sin \theta, \end{cases} \quad (3.1)$$

or arbitrary coordinates

$$\begin{cases} \xi = \xi(x, y) \\ \eta = \eta(x, y) \end{cases} \quad \begin{cases} d\xi = \frac{\partial \xi}{\partial x} dx + \frac{\partial \xi}{\partial y} dy \\ d\eta = \frac{\partial \eta}{\partial x} dx + \frac{\partial \eta}{\partial y} dy. \end{cases} \quad (3.2)$$

In making a coordinate transformation it is important to impose that to any two distinct points  $(x_1, y_1), (x_2, y_2)$  be assigned different pairs  $(\xi_1, \eta_1), (\xi_2, \eta_2)$ . This implies that if  $\Delta\xi = \Delta\eta = 0$ , where  $\Delta\xi$  and  $\Delta\eta$  are the distances between the two points along the coordinate axes, then the two points must coincide, i.e. it must also be  $\Delta x = \Delta y = 0$ . This is true if the determinant of eq. (3.2), i.e. the Jacobian associated to the coordinate transformation, is non-zero

$$\mathbf{J} = \begin{pmatrix} \frac{\partial \xi}{\partial x} & \frac{\partial \xi}{\partial y} \\ \frac{\partial \eta}{\partial x} & \frac{\partial \eta}{\partial y} \end{pmatrix} \neq 0. \quad (3.3)$$

If  $\mathbf{J}$  vanishes at a point, the transformation is said to be *singular* there.

### 3.1 The traditional definition of a vector

*A vector is a collection of  $D$  numbers ( $D = \text{dimensions of the space}$ ) which transform like the coordinates do under a coordinate transformation.*

For example, a typical vector is the displacement

$$\vec{ds} \rightarrow_0 (dx, dy), \quad (3.4)$$

or, in a more compact form

$$\vec{ds} \rightarrow_0 \{dx^\mu\}, \quad \mu = 1, 2, \quad (3.5)$$

where the arrow indicates that  $\vec{ds}$  has components with respect to a given frame  $O$ . If we now make a coordinate transformation, for example the transformation (3.2), the components of  $\vec{ds}$  transform accordingly

$$\begin{pmatrix} d\xi \\ d\eta \end{pmatrix} = \begin{pmatrix} \frac{\partial \xi}{\partial x} & \frac{\partial \xi}{\partial y} \\ \frac{\partial \eta}{\partial x} & \frac{\partial \eta}{\partial y} \end{pmatrix} \cdot \begin{pmatrix} dx \\ dy \end{pmatrix}. \quad (3.6)$$

If we put  $(x^1, x^2) = (\xi, \eta)$ , and  $(x^1, x^2) = (x, y)$ , eq. (3.6) can be rewritten in the more compact form

$$dx^{\mu'} = \sum_{\alpha=1,2} \frac{\partial x^{\mu'}}{\partial x^{\alpha}} dx^{\alpha} = \frac{\partial x^{\mu'}}{\partial x^{\alpha}} dx^{\alpha}. \quad (3.7)$$

( $\alpha$  is a dummy index). Then *contravariant vectors*  $\vec{A} \rightarrow_0 \{A^{\mu}\}$  are defined as objects that transform in the same way as  $\vec{ds}$

$$A^{\mu'} = \frac{\partial x^{\mu'}}{\partial x^{\beta}} A^{\beta}, \quad (3.8)$$

where  $A^{\mu'}$  are the components of the vector in the new frame. If we now define the matrix

$$(\Lambda^{\alpha'}_{\beta}) = \begin{pmatrix} \frac{\partial x^{1'}}{\partial x^1} & \frac{\partial x^{1'}}{\partial x^2} \\ \frac{\partial x^{2'}}{\partial x^1} & \frac{\partial x^{2'}}{\partial x^2} \end{pmatrix}, \quad (3.9)$$

the transformation law can be written in the general form

$$A^{\mu'} = \Lambda^{\alpha'}_{\beta} A^{\beta}. \quad (3.10)$$

In addition one can define *covariant vectors* as objects that transform according to the following rule

$$A_{\mu'} = \frac{\partial x^{\beta}}{\partial x^{\mu'}} A_{\beta} = \Lambda^{\beta}_{\mu'} A_{\beta}, \quad (3.11)$$

where  $\Lambda^{\beta}_{\mu'}$  is the inverse matrix of  $\Lambda^{\alpha'}_{\beta}$ . However, a vector is a geometrical object. In fact it is an arrow that joins two points of a given space. We can associate components to it, and when we rotate the reference frame they change, but the vector itself does not change. We shall now give a more adequate definition.

## 3.2 A geometrical definition

In order to define a vector as a geometrical object we need to introduce the notions of *paths* and *curves*.

### PATH

A path is a connected series of points in the plane (or in any arbitrary n-dimensional space)



**CURVE**

A curve is a path with a real number associated with each point of the path, i.e. it is a mapping of an interval of  $\mathbf{R}^1$  into a path in the plane. The number is called the *parameter*. For example

$$\text{curve} \quad : \{x^1 = f(s), x^2 = g(s), a \leq s \leq b\}, \quad (3.12)$$

means that each point of the path has coordinates that can be expressed as functions of  $s$ . The path is called *the image of the curve in the plane*. What happens if we change the parameter? If  $s' = s'(s)$  we shall get a new curve

$$\{x^1 = f'(s'), x^2 = g'(s'), a' \leq s' \leq b'\}, \quad (3.13)$$

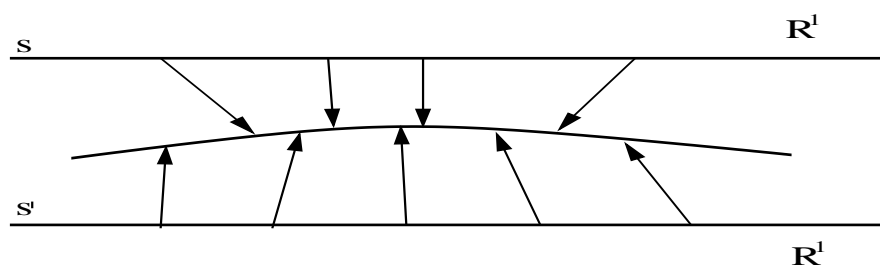

where  $f', g'$  are new functions of  $s'$ . This is a *new curve*, but with the same *image*. Thus there are an infinite number of curves corresponding to the same path.

FOR EXAMPLE: The position of a bullet shot by a gun in the 2-dimensional plane ( $x, z$ ) is a PATH; when we associate the parameter  $t$  (time) at each point of the trajectory, we define a CURVE; if we change the parameter, say for instance the curvilinear abscissa, we define a new curve.

**VECTORS**

**A vector is a geometrical object defined as the tangent vector to a given curve at a point P.**

The set of numbers  $\left\{\frac{dx^i}{ds}\right\} = \left(\frac{dx^1}{ds}, \frac{dx^2}{ds}\right)$  are the components of a vector tangent to the curve. (In fact if  $\{dx^i\}$  are infinitesimal displacements *along* the curve, dividing them by  $ds$  only changes the scale but not the direction of the displacement). Every curve has a unique tangent vector

$$\vec{V} \rightarrow \left\{\frac{dx^i}{ds}\right\}. \quad (3.14)$$

One must be careful and not to confuse the curve with the path. In fact a path has, at any given point, an infinite number of tangent vectors, all parallel, but with different length. The length depends on the parameter  $s$  that we choose to label the points of the path, and consequently it is different for different curves having the same image. **A curve has a unique tangent vector, since the path and the parameter are given.**

It should be remembered that a vector is tangent to an infinite number of different curves, for two different reasons. The first is that there are curves that are tangent to one another in P, and therefore have the same tangent vector:



The second is that a path can be reparametrized in such a way that its tangent vector remains the same.

We shall now derive how does a vector transform if we change the coordinate system, and put for example  $x^{1'} = x^1(x^1, x^2)$ ,  $x^{2'} = x^2(x^1, x^2)$ . The parameter  $s$  is unaffected, thus

$$\begin{cases} \frac{dx^{1'}}{ds} = \frac{\partial x^{1'}}{\partial x^1} \frac{dx^1}{ds} + \frac{\partial x^{1'}}{\partial x^2} \frac{dx^2}{ds} \\ \frac{dx^{2'}}{ds} = \frac{\partial x^{2'}}{\partial x^1} \frac{dx^1}{ds} + \frac{\partial x^{2'}}{\partial x^2} \frac{dx^2}{ds} \end{cases} \quad \begin{pmatrix} \frac{dx^{1'}}{ds} \\ \frac{dx^{2'}}{ds} \end{pmatrix} = \begin{pmatrix} \frac{\partial x^{1'}}{\partial x^1} & \frac{\partial x^{1'}}{\partial x^2} \\ \frac{\partial x^{2'}}{\partial x^1} & \frac{\partial x^{2'}}{\partial x^2} \end{pmatrix} \cdot \begin{pmatrix} \frac{dx^1}{ds} \\ \frac{dx^2}{ds} \end{pmatrix}$$

As expected, this is the same transformation as (3.10) that was used to define a contravariant vector

$$V^{\mu'} = \Lambda^{\mu'}_{\beta} V^{\beta}. \tag{3.15}$$

### 3.3 The directional derivative along a curve form a vector space at P

In order to understand the meaning of the statement contained in the heading of this section, let us consider a curve, parametrized with an assigned parameter  $\lambda$ , and a differentiable function  $\Phi(x^1, \dots, x^n)$ , in a general n-dimensional space. The directional derivative of  $\Phi$  along the curve will be

$$\frac{d\Phi}{d\lambda} = \frac{\partial \Phi}{\partial x^1} \frac{dx^1}{d\lambda} + \dots + \frac{\partial \Phi}{\partial x^n} \frac{dx^n}{d\lambda} = \frac{\partial \Phi}{\partial x^i} \frac{dx^i}{d\lambda}, \quad i = 1, \dots, n. \tag{3.16}$$

Since the function  $\Phi$  is totally arbitrary, we can rewrite this expression as

$$\frac{d}{d\lambda} = \frac{dx^i}{d\lambda} \frac{\partial}{\partial x^i}, \tag{3.17}$$

where  $\frac{d}{d\lambda}$  is now the operator of directional derivative, while  $\left\{ \frac{dx^i}{d\lambda} \right\}$  are the components of the tangent vector.

Let us consider two curves  $x^i = x^i(\lambda)$  and  $x^i = x^i(\mu)$  passing through the same point P, and write the two directional derivatives along the two curves

$$\frac{d}{d\lambda} = \frac{dx^i}{d\lambda} \frac{\partial}{\partial x^i}, \quad \frac{d}{d\mu} = \frac{dx^i}{d\mu} \frac{\partial}{\partial x^i}. \quad (3.18)$$

$\left\{ \frac{dx^i}{d\mu} \right\}$  are the components of the vector tangent to the second curve. Let us also consider a real number  $a$ .

- We define the *sum* of the two directional derivatives as the directional derivative

$$\frac{d}{d\lambda} + \frac{d}{d\mu} \equiv \left( \frac{dx^i}{d\lambda} + \frac{dx^i}{d\mu} \right) \frac{\partial}{\partial x^i}. \quad (3.19)$$

The numbers  $\left( \frac{dx^i}{d\lambda} + \frac{dx^i}{d\mu} \right)$  are the components of a new vector, which is certainly tangent to some curve through P. Thus there must exist a curve with a parameter, say,  $s$ , such that at P

$$\frac{d}{ds} = \left( \frac{dx^i}{d\lambda} + \frac{dx^i}{d\mu} \right) \frac{\partial}{\partial x^i} = \frac{d}{d\lambda} + \frac{d}{d\mu}. \quad (3.20)$$

- We define the *product* of the directional derivative  $\partial/\partial\lambda$  with the real number  $a$  as the directional derivative

$$a \frac{d}{d\lambda} \equiv \left( a \frac{dx^i}{d\lambda} \right) \frac{\partial}{\partial x^i}. \quad (3.21)$$

The numbers  $\left( a \frac{dx^i}{d\lambda} \right)$  are the components of a new vector, which is certainly tangent to some curve through P. Thus there must exist a curve with a parameter, say,  $s'$ , such that at P

$$\frac{d}{ds'} = \left( a \frac{dx^i}{d\lambda} \right) \frac{\partial}{\partial x^i} = a \frac{d}{d\lambda}. \quad (3.22)$$

In this way we have defined two operations on the space of the directional derivatives along the curves passing through a point  $P$ : the sum of two directional derivatives, and the multiplication of a directional derivative with a real number.

We remind the mathematical definition of a vector space<sup>1</sup>.

*A vector space is a set  $V$  on which two operations are defined:*

1. *Vector addition*

$$(\vec{v}, \vec{w}) \rightarrow \vec{v} + \vec{w} \quad (3.23)$$

2. *Multiplication by a real number:*

$$(a, \vec{v}) \rightarrow a\vec{v} \quad (3.24)$$

*(where  $\vec{v}, \vec{w} \in V$ ,  $a \in \mathbb{R}$ ), which satisfy the following properties:*

---

<sup>1</sup>To be precise, what we are defining here is a *real* vector space, but we will omit this specification, because in this book only real vector spaces will be considered.

- *Associativity and commutativity of vector addition*

$$\begin{aligned}\vec{v} + (\vec{w} + \vec{u}) &= (\vec{v} + \vec{w}) + \vec{u} \\ \vec{v} + \vec{w} &= \vec{w} + \vec{v}. \quad \forall \vec{v}, \vec{w}, \vec{u} \in V.\end{aligned}\tag{3.25}$$

- *Existence of a zero vector, i.e. of an element  $\vec{0} \in V$  such that*

$$\vec{v} + \vec{0} = \vec{v} \quad \forall \vec{v} \in V.$$

- *Existence of the opposite element: for every  $\vec{w} \in V$  there exists an element  $\vec{v} \in V$  such that*

$$\vec{v} + \vec{w} = \vec{0}.$$

- *Associativity and distributivity of multiplication by real numbers:*

$$\begin{aligned}a(b\vec{v}) &= (ab)\vec{v} \\ a(\vec{v} + \vec{w}) &= a\vec{v} + a\vec{w} \\ (a + b)\vec{v} &= a\vec{v} + b\vec{v} \quad \forall \vec{v} \in V, \forall a, b \in \mathbb{R}.\end{aligned}\tag{3.26}$$

- *Finally, the real number 1 must act as an identity on vectors:*

$$1\vec{v} = \vec{v} \quad \forall \vec{v}.\tag{3.27}$$

Coming back to directional derivatives (taken at a given point  $P$  of the manifold), it is easy to verify that the operations of addition and multiplication by a real number defined in (3.19),(3.21) respectively, satisfy the above properties. For instance:

- *Commutativity of the addition:*

$$\frac{d}{d\lambda} + \frac{d}{d\mu} = \left( \frac{dx^i}{d\lambda} + \frac{dx^i}{d\mu} \right) \frac{\partial}{\partial x^i} = \left( \frac{dx^i}{d\mu} + \frac{dx^i}{d\lambda} \right) \frac{\partial}{\partial x^i} = \frac{d}{d\mu} + \frac{d}{d\lambda}.\tag{3.28}$$

- *Associativity of multiplication by real numbers:*

$$\begin{aligned}a \left( b \frac{d}{d\lambda} \right) &= a \left( \left( b \frac{dx^i}{d\lambda} \right) \frac{\partial}{\partial x^i} \right) \\ &= \left( a \left( b \frac{dx^i}{d\lambda} \right) \right) \frac{\partial}{\partial x^i} = \left( ab \frac{dx^i}{d\lambda} \right) \frac{\partial}{\partial x^i} \\ &= ab \frac{d}{d\lambda}.\end{aligned}\tag{3.29}$$

- *Distributivity of multiplication by real numbers:*

$$\begin{aligned}a \left( \frac{d}{d\lambda} + \frac{d}{d\mu} \right) &= a \left( \left( \frac{dx^i}{d\lambda} + \frac{dx^i}{d\mu} \right) \frac{\partial}{\partial x^i} \right) \\ &= \left( a \left( \frac{dx^i}{d\lambda} + \frac{dx^i}{d\mu} \right) \right) \frac{\partial}{\partial x^i} = \left( a \frac{dx^i}{d\lambda} + a \frac{dx^i}{d\mu} \right) \frac{\partial}{\partial x^i} \\ &= \left( a \frac{dx^i}{d\lambda} \right) \frac{\partial}{\partial x^i} + \left( a \frac{dx^i}{d\mu} \right) \frac{\partial}{\partial x^i} = a \frac{d}{d\lambda} + a \frac{d}{d\mu}.\end{aligned}\tag{3.30}$$

- The zero element is the vector tangent to the curve  $x^\mu \equiv \text{const.}$ , which is simply the point  $P$ .
- The opposite of the vector  $\vec{v}$  tangent to a given curve is obtained by changing sign to the parametrization

$$\lambda \rightarrow -\lambda. \quad (3.31)$$

The proof of the remaining properties is analogous.

**Therefore, the set of directional derivatives is a vector space.**

In any coordinate system there are special curves, the coordinate lines (think for example to the grid of cartesian coordinates). The directional derivatives along these lines are

$$\frac{d}{dx^i} = \frac{dx^k}{dx^i} \frac{\partial}{\partial x^k} = \delta_i^k \frac{\partial}{\partial x^k} = \frac{\partial}{\partial x^i},$$

Eq. (3.17) shows that the generic directional derivative  $\frac{d}{d\lambda}$  can always be expressed as a linear combination of  $\frac{\partial}{\partial x^i}$ . It follows that  $\frac{d}{dx^i} \equiv \frac{\partial}{\partial x^i}$  are a basis for this vector space, and  $\{\frac{dx^i}{d\lambda}\}$  are the components of  $\frac{d}{d\lambda}$  on this basis. But  $\{\frac{dx^i}{d\lambda}\}$  are also the components of a tangent vector at P. Therefore *the space of all tangent vectors and the space of all derivatives along curves at P are in 1-1 correspondence*. For this reason we can say that  $\frac{d}{d\lambda}$  is the vector tangent to the curve  $x^i(\lambda)$ .

TO SUMMARIZE: the vectors tangent to the coordinate lines in a point P, i.e. the directional derivatives in P along these lines in a coordinate system  $(x^1, \dots, x^n)$ , have the following components

$$\frac{\vec{\partial}}{\partial x^1} = (1, 0, \dots, 0), \quad \frac{\partial}{\partial x^2} = (0, 1, \dots, 0), \quad \dots, \quad \frac{\partial}{\partial x^n} = (0, 0, \dots, 1).$$

If we use the  $\left\{\frac{\vec{\partial}}{\partial x^i}\right\}$  as a basis for vectors, the vector  $\frac{\vec{d}}{d\lambda}$ , tangent to the curve  $x^i(\lambda)$ , with respect to this basis has components  $\left\{\frac{dx^i}{d\lambda}\right\}$ .

*Vectors do not lie in  $\mathbf{M}$ , but in the tangent space to  $M$ , called  $\mathbf{T}_P$*  For example in the two-dimensional case analysed above the tangent plane was the plane itself, but if the manifold is a sphere, since we cannot define a vector as an “arrow” on the sphere, we need to define the tangent space, i.e. the plane tangent to the sphere at each point. For more general manifolds it is not easy to visualize  $\mathbf{T}_P$ . In any event  $\mathbf{T}_P$  has the same dimensions as the manifold  $\mathbf{M}$ .

### 3.4 Coordinate bases

Any collection of  $n$  linearly independent vectors of  $\mathbf{T}_P$  is a basis for  $\mathbf{T}_P$ . However, a natural basis is provided by the vectors that are tangent to the coordinate lines, i.e.  $\left\{\vec{e}_{(i)}\right\} \equiv \left\{\frac{\vec{\partial}}{\partial x^{(i)}}\right\}$ ; this is *the coordinate basis*.

IMPORTANT:

To hereafter, we shall enclose within ( ) the indices that indicate which vector of the basis we are choosing, not to be confused with the index which indicates the vector components. For instance  $e_{(2)}^1$  indicates the component 1 of the basis vector  $\vec{e}_{(2)}$ .

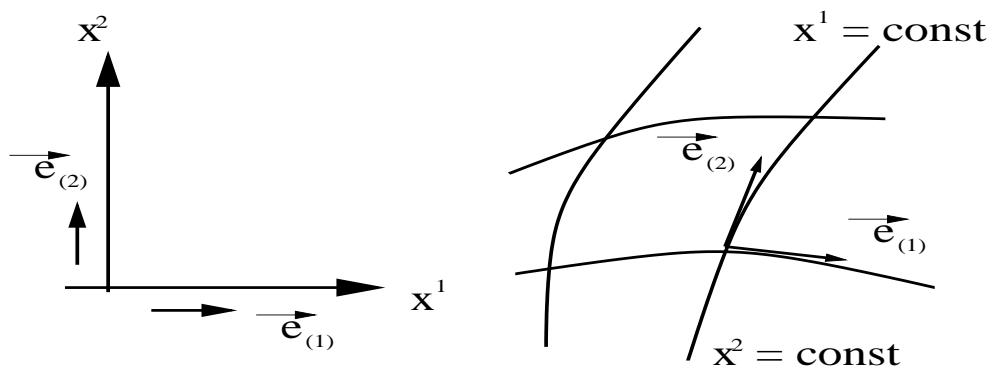

Any vector  $\vec{A}$  at a point P, can be expressed as a linear combination of the basis vectors

$$\vec{A} = A^i \vec{e}_{(i)}, \quad (3.32)$$

(Remember Einstein's convention:  $\sum_i A^i \vec{e}_{(i)} \equiv A^i \vec{e}_{(i)}$ ) where the numbers  $\{A^i\}$  are the components of  $\vec{A}$  with respect to the chosen basis.

If we make a coordinate transformation to a new set of coordinates  $(x^{1'}, x^{2'}, \dots, x^{n'})$ , there will be a new coordinate basis:  $\{\vec{e}_{(i')}\} \equiv \left\{ \frac{\vec{\partial}}{\partial x^{(i')}}} \right\}$ .

We now want to find the relation between the new and the old basis, i.e we want to express each new vector  $\vec{e}_{(j')}$  as a linear combination of the old ones  $\{\vec{e}_{(j)}\}$ . In the new basis, the vector  $\vec{A}$  will be written as

$$\vec{A} = A^{j'} \vec{e}_{(j')}, \quad (3.33)$$

where  $\{A^{j'}\}$  are the components of  $\vec{A}$  with respect to the basis  $\{\vec{e}_{(j')}\}$ . But the vector  $\vec{A}$  is the same in any basis, therefore

$$A^i \vec{e}_{(i)} = A^{j'} \vec{e}_{(j')}. \quad (3.34)$$

From eq. (3.15) we know how to express  $A^{j'}$  as functions of the components in the old basis, and substituting these expressions into eq. (3.34) we find

$$A^i \vec{e}_{(i)} = \Lambda^{i'}_k A^k \vec{e}_{(i')}. \quad (3.35)$$

By relabelling the dummy indices this equation can be written as

$$\left[ \Lambda^{i'}_{\ k} \vec{e}_{(i')} - \vec{e}_{(k)} \right] A^k = 0, \quad (3.36)$$

i.e.

$$\vec{e}_{(k)} = \Lambda^{i'}_{\ k} \vec{e}_{(i')}. \quad (3.37)$$

Multiplying both members by  $\Lambda^k_{\ j'}$  and remembering that

$$\Lambda^k_{\ j'} \Lambda^{i'}_{\ k} = \frac{\partial x^k}{\partial x^{j'}} \frac{\partial x^{i'}}{\partial x^k} = \frac{\partial x^{i'}}{\partial x^{j'}} = \delta^{i'}_{\ j'} \quad (3.38)$$

we find the transformation we were looking for

$$\vec{e}_{(j')} = \Lambda^k_{\ j'} \vec{e}_{(k)}. \quad (3.39)$$

Summarizing:

$$\begin{cases} \vec{e}_{(k)} = \Lambda^{i'}_{\ k} \vec{e}_{(i')}, \\ \vec{e}_{(i')} = \Lambda^k_{\ i'} \vec{e}_{(k)}. \end{cases} \quad (3.40)$$

We are now in a position to compute the new basis vectors in terms of the old ones.

#### EXAMPLE

Consider the 4-dimensional flat spacetime of Special Relativity, but let us restrict to the (x-y) plane, where we choose the coordinates  $(ct, x, y) \equiv (x^0, x^1, x^2)$ . The *coordinate basis* is the set of vectors

$$\begin{aligned} \frac{\vec{\partial}}{\partial x^{(0)}} &= \vec{e}_{(0)} \rightarrow (1, 0, 0) \\ \frac{\vec{\partial}}{\partial x^{(1)}} &= \vec{e}_{(1)} \rightarrow (0, 1, 0) \\ \frac{\vec{\partial}}{\partial x^{(2)}} &= \vec{e}_{(2)} \rightarrow (0, 0, 1), \end{aligned} \quad (3.41)$$

or, in a compact form

$$e^{\beta}_{(\alpha)} = \delta^{\beta}_{\alpha}. \quad (3.42)$$

(The superscript  $\beta$  now indicates the  $\beta$ -component of the  $\alpha$ -th vector). In this basis any vector  $\vec{A}$  can be written as

$$\vec{A} = A^0 \vec{e}_{(0)} + A^1 \vec{e}_{(1)} + A^2 \vec{e}_{(2)} = A^{\alpha} \vec{e}_{(\alpha)}, \quad \alpha = 0, ..3 \quad (3.43)$$

where  $\{A^i\} = (A^0, A^1, A^2)$  are the components of  $\vec{A}$  with respect to this basis. Let us consider the following coordinate transformation

$$\begin{cases} (x^0, x, y) \rightarrow (x^0, r, \theta) \\ x^0 = x^{0'} \\ x^1 = r \cos \theta \\ x^2 = r \sin \theta, \end{cases} \quad (3.44)$$

i.e.  $x^{1'} = r, x^{2'} = \theta$ . The new coordinate basis is

$$\frac{\vec{\partial}}{\partial x^{(0')}} = \vec{e}_{(0')}, \quad \frac{\vec{\partial}}{\partial r} \equiv \frac{\vec{\partial}}{\partial x^{(1')}} = \vec{e}_{(1')}, \quad \frac{\vec{\partial}}{\partial \theta} \equiv \frac{\vec{\partial}}{\partial x^{(2')}} = \vec{e}_{(2')}. \quad (3.45)$$

From eq. (3.39) we find

$$\vec{e}_{(0')} = \Lambda^k{}_{0'} \vec{e}_{(k)}, \quad \Lambda^k{}_{0'} = \frac{\partial x^k}{\partial x^{0'}}. \quad (3.46)$$

In the example we are considering only  $\Lambda^0{}_{0'} \neq 0$  and it is equal to 1. It follows that

$$\vec{e}_{(0)} \equiv \frac{\vec{\partial}}{\partial x^{(0')}} = \vec{e}_{(0')}. \quad (3.47)$$

In addition

$$\vec{e}_{(1')} = \Lambda^k{}_{1'} \vec{e}_{(k)}, \quad (3.48)$$

and since

$$\Lambda^0{}_{1'} = \frac{\partial x^0}{\partial r} = 0, \quad \Lambda^1{}_{1'} = \frac{\partial x^1}{\partial r} = \cos \theta, \quad \Lambda^2{}_{1'} = \frac{\partial x^2}{\partial r} = \sin \theta, \quad (3.49)$$

$$\vec{e}_{(1')} \equiv \frac{\vec{\partial}}{\partial r} = \cos \theta \vec{e}_{(1)} + \sin \theta \vec{e}_{(2)}. \quad (3.50)$$

Similarly

$$\vec{e}_{(2')} = \Lambda^k{}_{2'} \vec{e}_{(k)}, \quad (3.51)$$

and since

$$\Lambda^0{}_{2'} = 0, \quad \Lambda^1{}_{2'} = \frac{\partial x^1}{\partial \theta} = -r \sin \theta, \quad \Lambda^2{}_{2'} = \frac{\partial x^2}{\partial \theta} = r \cos \theta, \quad (3.52)$$

hence

$$\vec{e}_{(2')} \equiv \frac{\vec{\partial}}{\partial \theta} = -r \sin \theta \vec{e}_{(1)} + r \cos \theta \vec{e}_{(2)}. \quad (3.53)$$

It should be noted that we do not need to choose necessarily a coordinate basis. We may choose a set of independent basis vectors that are not tangent to the coordinate lines. In this case the matrix which allows to transform from one basis to another has to be assigned and will not be  $\Lambda^i{}_{i'}$  as in eq. (3.39).

### 3.5 One-forms

**A one-form is a linear, real valued function of vectors.** This means the following: a one-form (or 1-form)  $\tilde{q}$  at the point P takes the vector  $\vec{V}$  at P and associates a number to it, which we call  $\tilde{q}(\vec{V})$ . To hereafter a “ $\sim$ ” will indicate 1-forms, as an arrow “ $\rightarrow$ ” indicates vectors.

By definition, a one-form is linear. This means that, for every couple of vectors  $\vec{V}, \vec{W}$ , for every couple of real numbers  $a, b$ , for every one-form  $\tilde{q}$ ,

$$\tilde{q}(a\vec{V} + b\vec{W}) = a\tilde{q}(\vec{V}) + b\tilde{q}(\vec{W}). \quad (3.54)$$

We define two operations acting on the space of one-forms:

- Multiplication by real numbers: given a one-form  $\tilde{q}$  and a real number  $a$ , we define the new one-form  $a\tilde{q}$  such that, for every vector  $\vec{V}$ ,

$$(a\tilde{q})(\vec{V}) = a[\tilde{q}(\vec{V})]. \quad (3.55)$$

- Addition: given two one-forms  $\tilde{q}, \tilde{\sigma}$ , we define the new one-form  $\tilde{q} + \tilde{\sigma}$  such that, for every vector  $\vec{V}$ ,

$$[\tilde{q} + \tilde{\sigma}](\vec{V}) = \tilde{q}(\vec{V}) + \tilde{\sigma}(\vec{V}). \quad (3.56)$$

One-forms satisfy the axioms (3.25-3.27). Let us show this for some of the axioms.

- Commutativity of addition. Given two one-forms  $\tilde{q}, \tilde{\sigma}$ , we have that, for every vector field  $\vec{V}$ ,

$$(\tilde{q} + \tilde{\sigma})(\vec{V}) = \tilde{q}(\vec{V}) + \tilde{\sigma}(\vec{V}) = \tilde{\sigma}(\vec{V}) + \tilde{q}(\vec{V}) = (\tilde{\sigma} + \tilde{q})(\vec{V}). \quad (3.57)$$

- Distributivity of multiplication with real numbers. Given two one-forms  $\tilde{q}, \tilde{\sigma}$  and a real number  $a$ , we have that, for every vector field  $\vec{V}$ ,

$$\begin{aligned} [a(\tilde{q} + \tilde{\sigma})](\vec{V}) &= a[(\tilde{q} + \tilde{\sigma})](\vec{V}) = a[\tilde{q}(\vec{V}) + \tilde{\sigma}(\vec{V})] \\ &= a[\tilde{q}(\vec{V})] + a[\tilde{\sigma}(\vec{V})] = (a\tilde{q})(\vec{V}) + (a\tilde{\sigma})(\vec{V}) \\ &= [(a\tilde{q}) + (a\tilde{\sigma})](\vec{V}) \end{aligned} \quad (3.58)$$

then, being this true for every  $\vec{V}$ ,

$$a(\tilde{q} + \tilde{\sigma}) = (a\tilde{q}) + (a\tilde{\sigma}). \quad (3.59)$$

- Existence of the zero element. The zero one-form  $\tilde{0}$  is the one-form such that, for every  $\vec{V}$ ,

$$\tilde{0}(\vec{V}) = 0. \quad (3.60)$$

The other axioms can be proved in a similar way.

Therefore, one-forms form a vector space, which is called the **dual** vector space to  $\mathbf{T}_{\mathbf{p}}$ , and it is indicated as  $\mathbf{T}_{\mathbf{p}}^*$ .

$\mathbf{T}_{\mathbf{p}}^*$  is the space of the maps (the 1-forms) that associate to any given vector a number, i.e. that map  $\mathbf{T}_{\mathbf{p}}$  on  $\mathbf{R}^1$ . The reason why  $\mathbf{T}_{\mathbf{p}}^*$  is called dual to  $\mathbf{T}_{\mathbf{p}}$  is that vectors also can be regarded as linear, real valued functions of one-forms: a vector  $\vec{V}$  takes a 1-form  $\tilde{q}$  and associates a number to it, which we call  $\vec{V}(\tilde{q})$ , and

$$\tilde{q}(\vec{V}) \equiv \vec{V}(\tilde{q}), \quad (3.61)$$

in the sense that the two “operations” give as a result the same number. This point will be further clarified in the following. Once we choose a basis for vectors, say  $\{\vec{e}_{(i)}, i = 1, n\}$ , we can introduce a dual basis for one-forms defined as follows:

*the dual basis*  $\{\tilde{\omega}^{(i)}, i = 1, n\}$ , takes any vector  $\vec{V}$  in  $\mathbf{T}_{\mathbf{p}}$  and produces its components

$$\tilde{\omega}^{(i)}(\vec{V}) = V^i. \quad (3.62)$$

It should be remembered that an index in parenthesis does not refer to a component, but selects the -th one-form (or vector) of the basis. Thus the i-th basis one-form applied to  $\vec{V}$

gives as a result a number, which is the component  $V^i$  of the vector  $\vec{V}$ . As expected, this operation is linear in the argument

$$\tilde{\omega}^{(i)}(\vec{V} + \vec{W}) = V^i + W^i, \quad (3.63)$$

since  $\vec{V} + \vec{W}$  is a vector whose  $i$ -th component is  $V^i + W^i$ . In particular, if the argument of a one-form is  $\vec{e}_{(j)}$ , i.e. one of the basis vectors of the tangent space at the point  $\mathbf{P}$ , since only the  $j$ -th component of  $\vec{e}_{(j)}$  is different from zero and equal to 1, we have

$$\tilde{\omega}^{(i)}(\vec{e}_{(j)}) = \delta_j^i. \quad (3.64)$$

We now want to answer the questions:

1. Who tells us that  $\{\tilde{\omega}^{(i)}\}$  form a basis for one-forms?
2. Can we define the components of a 1-form as we define the components of a vector?

1. Consider any one-form  $\tilde{q}$  acting on an arbitrary vector  $\vec{V}$ . By expressing  $\vec{V}$  as a linear combination of the basis vectors  $\vec{e}_{(j)}$ , and using the linearity of one-forms we can write

$$\begin{aligned} \tilde{q}(\vec{V}) &= \tilde{q}(V^j \vec{e}_{(j)}) = V^j \tilde{q}(\vec{e}_{(j)}) = \\ &= \tilde{\omega}^{(j)}(\vec{V}) \tilde{q}(\vec{e}_{(j)}), \end{aligned} \quad (3.65)$$

where the last equality follows from eq.(3.62). This equation holds for any vector  $\vec{V}$  therefore we can write

$$\tilde{q} = \tilde{\omega}^{(j)} \tilde{q}(\vec{e}_{(j)}); \quad (3.66)$$

since  $\tilde{q}(\vec{e}_{(j)})$  are real numbers, this equation shows that any one-form  $\tilde{q}$  can be written as a linear combination of the  $\{\tilde{\omega}^{(j)}\}$ ; consequently  $\{\tilde{\omega}^{(j)}\}$  form a basis for one-forms.

2. We now define *the components of  $\tilde{q}$  on the basis  $\{\tilde{\omega}^{(i)}\}$*  as

$$q_j = \tilde{q}(\vec{e}_{(j)}) \quad (3.67)$$

and consequently we can write

$$\tilde{q} = q_j \tilde{\omega}^{(j)}. \quad (3.68)$$

Consider an open region of spacetime  $U$ , and choose a coordinate system  $\{x^i\}$ . We have seen that this defines a *natural coordinate basis for vectors*  $\vec{e}_{(i)} \equiv \{\frac{\partial}{\partial x^{(i)}}\}$ . Furthermore, it also defines a *natural coordinate basis for one-forms* (dual to the natural basis for vectors), often indicated as  $\{\tilde{d}x^{(i)}\}$ , whose components are

$$\tilde{\omega}^{(i)}_j \equiv \tilde{d}x^{(i)}_j = \tilde{d}x^{(i)} \left( \frac{\partial}{\partial x^{(j)}} \right) = \delta_j^i.$$

And now the most important thing. From eq. (3.68) it follows that for any vector  $\vec{V}$

$$\tilde{q}(\vec{V}) = q_j \tilde{\omega}^{(j)}(\vec{V}). \quad (3.69)$$

Since  $\tilde{\omega}^{(j)}(\vec{V}) = V^j$ , we find

$$\tilde{q}(\vec{V}) = q_j V^j. \quad (3.70)$$

This operation is called **contraction** and tells us how to compute the number which results from the application of  $\tilde{q}$  on  $\vec{V}$  (or viceversa), once we know the components of  $\tilde{q}$  and  $\vec{V}$ .

---

From eq. (3.70) we can now better understand why vectors and one-forms are dual of each other. In fact, if  $q_j$  and  $V^j$  are respectively the components of the one-form  $\tilde{q}$  and of the vector  $\vec{V}$

$$\tilde{q}(\vec{V}) = q_j V^j = q_0 V^0 + q_1 V^1 + \dots q_n V^n; \quad (3.71)$$

The right-hand side of this equation can be considered as a linear combination of the components of  $\vec{V}$  with coefficients  $q_j$ , or alternatively, as a linear combination of the components of  $\tilde{q}$  with coefficients  $V^j$ , and this follows from the linearity of the previous expression. Therefore, we can define vectors as those linear functions that, when applied to one-forms, produce a number.

---

Let us now make a coordinate transformation  $x^{\mu'} = x^{\mu'}(x^i)$ . and let us consider the

1. How do the components of one-forms transform?
2. Will the new coordinate basis for one-forms be a linear combination of the old ones, and if so, and which combination?

- 
1. By definition

$$q_j = \tilde{q}(\vec{e}_{(j)}). \quad (3.72)$$

If we change coordinates, we will have a new set of basis vectors  $\{\vec{e}_{(j')}\}$ , and we have seen that they are related to the old ones by

$$\vec{e}_{(i')} = \Lambda^k_{i'} \vec{e}_{(k)}, \quad (3.73)$$

where  $\Lambda^k_{\mu'} = \frac{\partial x^k}{\partial x^{\mu'}}$ . The new components of  $\tilde{q}$  will be

$$q_{j'} = \tilde{q}(\vec{e}_{(j')}) = \tilde{q}[\Lambda^k_{j'} \vec{e}_{(k)}] = \Lambda^k_{j'} \tilde{q}(\vec{e}_{(k)}) = \Lambda^k_{j'} q_k, \quad (3.74)$$

hence

$$q_{j'} = \Lambda^k_{j'} q_k. \quad (3.75)$$

If we compare this result with eq. (3.11) we immediately recognize that this is the way covariant vectors transform, thus *covariant vectors are one-forms*.

2. We now want to check whether the new basis one-forms can be expressed as a linear combination of the old ones. We shall proceed along the same lines of section 3.4. From eq. (3.68) we see that

$$\tilde{q} = q_j \tilde{\omega}^{(j)} = q_{k'} \tilde{\omega}^{(k')}, \quad (3.76)$$

(sum removed according to Einstein's convention), where  $\{\tilde{\omega}^{(k')}\}$  are the new basis one-forms. But

$$q_{k'} = \Lambda^i{}_{k'} q_i, \quad (3.77)$$

therefore

$$q_j \tilde{\omega}^{(j)} = \Lambda^i{}_{k'} q_i \tilde{\omega}^{(k')}. \quad (3.78)$$

This equation can be rewritten as

$$[\Lambda^i{}_{k'} \tilde{\omega}^{(k')} - \tilde{\omega}^{(i)}] q_i = 0, \quad (3.79)$$

hence

$$\tilde{\omega}^{(i)} = \Lambda^i{}_{k'} \tilde{\omega}^{(k')}. \quad (3.80)$$

The matrix  $\Lambda^i{}_{j'}$  is inverse of  $\Lambda^{k'}{}_i$ . Thus

$$\Lambda^{k'}{}_j \Lambda^j{}_{i'} = \delta^{k'}{}_{i'}, \quad \text{or} \quad \Lambda^{k'}{}_j \Lambda^i{}_{k'} = \delta^i{}_j. \quad (3.81)$$

Multiplying both sides of eq. (3.80) by  $\Lambda^{j'}{}_i$  we find

$$\Lambda^{j'}{}_i \tilde{\omega}^{(i)} = \Lambda^{j'}{}_i \Lambda^i{}_{k'} \tilde{\omega}^{(k')} = \delta^{j'}{}_{k'} \tilde{\omega}^{(k')}, \quad (3.82)$$

hence

$$\tilde{\omega}^{(j')} = \Lambda^{j'}{}_i \tilde{\omega}^{(i)}, \quad (3.83)$$

Summarizing, the transformation laws for the basis one-forms are

$$\begin{cases} \tilde{\omega}^{(i)} = \Lambda^i{}_{k'} \tilde{\omega}^{(k')} \\ \tilde{\omega}^{(k')} = \Lambda^{k'}{}_j \tilde{\omega}^{(j)} \end{cases} \quad (3.84)$$

### EXAMPLE

Let us consider the same coordinate transformation analyzed in section 3.4. We start with minkowskian coordinates  $(x^0, x^1, x^2)$ . The coordinate basis for vectors is  $\{\frac{\partial}{\partial x^{(i)}}\}$  and the dual basis for one-forms is  $\{\tilde{d}x^{(i)}\}$

$$\tilde{d}x^{(0)} \rightarrow (1, 0, 0) \quad (3.85)$$

$$\tilde{d}x^{(1)} \rightarrow (0, 1, 0) \quad (3.86)$$

$$\tilde{d}x^{(2)} \rightarrow (0, 0, 1) \quad (3.87)$$

If we now change to polar coordinates  $(x^{0'} = x^0, x^{1'} = r, x^{2'} = \theta)$ , according to eq. (3.83) we find

$$\tilde{\omega}^{(0')} = \Lambda^{0'}{}_j \tilde{d}x^{(j)}. \quad (3.88)$$

Since  $\Lambda^{0'}_j = \frac{\partial x^{0'}}{\partial x^j}$ , only  $\Lambda^{0'}_0 = 1 \neq 0$ , thus

$$\tilde{\omega}^{(0')} = \tilde{d}x^{(0)}. \quad (3.89)$$

Similarly

$$\tilde{\omega}^{(1')} = \Lambda^{1'}_j \tilde{d}x^{(j)} = \frac{\partial x^{1'}}{\partial x^j} \tilde{d}x^{(j)} = \frac{\partial x^{1'}}{\partial x^1} \tilde{d}x^{(1)} + \frac{\partial x^{1'}}{\partial x^2} \tilde{d}x^{(2)}. \quad (3.90)$$

Since

$$\frac{\partial x^{1'}}{\partial x^1} = \frac{x^1}{x^{1'}} = \cos \theta, \quad \text{and} \quad \frac{\partial x^{1'}}{\partial x^2} = \frac{x^2}{x^{1'}} = \sin \theta \quad (3.91)$$

it follows that

$$\tilde{\omega}^{(1')} = \cos \theta \tilde{d}x^1 + \sin \theta \tilde{d}x^2. \quad (3.92)$$

Moreover

$$\tilde{\omega}^{(2')} = \frac{\partial x^{2'}}{\partial x^1} \tilde{d}x^{(1)} + \frac{\partial x^{2'}}{\partial x^2} \tilde{d}x^{(2)}, \quad (3.93)$$

hence

$$\tilde{\omega}^{(2')} = -\frac{1}{r} \sin \theta \tilde{d}x^{(1)} + \frac{1}{r} \cos \theta \tilde{d}x^{(2)}. \quad (3.94)$$

#### AN EXAMPLE OF ONE-FORM.

Consider a scalar field  $\Phi(x^0, x^1, \dots, x^n)$ . The gradient of a scalar field is

$$\tilde{\Phi} \rightarrow \left( \frac{\partial \Phi}{\partial x^0}, \frac{\partial \Phi}{\partial x^1}, \dots, \frac{\partial \Phi}{\partial x^n} \right). \quad (3.95)$$

It is easy to see, for example, that the components transform according to eq. (3.75), in fact

$$\tilde{\Phi}_j = \frac{\partial \Phi}{\partial x^j}, \quad \text{and} \quad \tilde{\Phi}_{j'} = \frac{\partial \Phi}{\partial x^{j'}} = \frac{\partial \Phi}{\partial x^k} \cdot \frac{\partial x^k}{\partial x^{j'}}, \quad (3.96)$$

since  $\Lambda^k_{j'} = \frac{\partial x^k}{\partial x^{j'}}$ , it follows that

$$\tilde{\Phi}_{j'} = \Lambda^k_{j'} \tilde{\Phi}_k, \quad (3.97)$$

same as eq. (3.75). Thus the gradient of a scalar field is a one-form.

# Chapter 4

## Tensors

### 4.1 Geometrical definition of a Tensor

The definition of a tensor is a generalization of the definition of one-forms.

Consider a point  $P$  of a manifold  $M$ . A tensor of type  $\begin{pmatrix} N \\ N' \end{pmatrix}$  at  $P$  is defined to be a linear function which takes as arguments  $N$  one-forms and  $N'$  vectors and associates a number to them.

For example if  $F$  is a  $\begin{pmatrix} 2 \\ 2 \end{pmatrix}$  tensor this means that

$$F(\tilde{\omega}, \tilde{\sigma}, \vec{V}, \vec{W})$$

is a number and the linearity implies that

$$F(a\tilde{\omega} + b\tilde{g}, \tilde{\sigma}, \vec{V}, \vec{W}) = aF(\tilde{\omega}, \tilde{\sigma}, \vec{V}, \vec{W}) + bF(\tilde{g}, \tilde{\sigma}, \vec{V}, \vec{W})$$

and

$$F(\tilde{\omega}, \tilde{g}, a\vec{V}_1 + b\vec{V}_2, \vec{W}) = aF(\tilde{\omega}, \tilde{g}, \vec{V}_1, \vec{W}) + bF(\tilde{\omega}, \tilde{g}, \vec{V}_2, \vec{W})$$

and similarly for the other arguments.

This definition of tensors is rather abstract, but we shall see how to make it concrete with specific examples.

The order in which the arguments are placed is important, as it is true for any function of real variables. For example if

$$f(x, y) = 4x^3 + 5y \quad , \text{ then } \quad f(1, 5) \neq f(5, 1). \quad (4.1)$$

In the same way

$$F(\tilde{\omega}, \tilde{g}, \vec{V}, \vec{W}) \neq F(\tilde{g}, \tilde{\omega}, \vec{V}, \vec{W}). \quad (4.2)$$

#### EXAMPLES

A  $\begin{pmatrix} 0 \\ 1 \end{pmatrix}$  tensor is a function that takes a vector as argument, and produces a number.

This is precisely what one-forms do (on the other hand this *is* the definition of one-forms).

Thus a  $\begin{pmatrix} 0 \\ 1 \end{pmatrix}$  tensor is a one-form.

$$\tilde{q}(\vec{V}) = \sum_j q_j V^j \equiv q_j V^j. \quad (4.3)$$

A  $\begin{pmatrix} 1 \\ 0 \end{pmatrix}$  tensor is a function that takes a one-form as an argument, and produces a number.

Thus a  $\begin{pmatrix} 1 \\ 0 \end{pmatrix}$  tensor is a vector

$$\vec{V}(\tilde{q}) = q_j V^j. \quad (4.4)$$

Let us now consider a  $\begin{pmatrix} 0 \\ 2 \end{pmatrix}$  tensor. It is a function that takes 2 vectors and associates a number to them.

Let us first define the tensor components: generalizing the definition (3.67) for the components of a one-form, they are the numbers that are obtained when the  $\begin{pmatrix} 0 \\ 2 \end{pmatrix}$  tensor is applied to the basis vectors:

$$F_{\alpha\beta} = F(\vec{e}_{(\alpha)}, \vec{e}_{(\beta)}); \quad (4.5)$$

since there are  $n$  basis vectors,  $F_{\alpha\beta}$  will be an  $n \times n$  matrix.

If we now take as arguments of  $F$  two arbitrary vectors  $\vec{A}$  and  $\vec{B}$  we find

$$\begin{aligned} F(\vec{A}, \vec{B}) &= F(A^\alpha \vec{e}_{(\alpha)}, B^\beta \vec{e}_{(\beta)}) = \\ &= A^\alpha B^\beta F(\vec{e}_{(\alpha)}, \vec{e}_{(\beta)}) = \\ &= F_{\alpha\beta} A^\alpha B^\beta. \end{aligned} \quad (4.6)$$

It should be stressed that in going from the first to the second line of eq. (4.6) we have used the property that tensors are linear functions of the arguments.

It is now clear what is the number that  $F$  associates to the two vectors: the number is  $F_{\alpha\beta} A^\alpha B^\beta$ .

We shall now construct a basis for  $\begin{pmatrix} 0 \\ 2 \end{pmatrix}$  tensors as we did for one-forms.

We want to write

$$F = F_{\alpha\beta} \tilde{\omega}^{(\alpha)(\beta)} \quad (4.7)$$

where  $\tilde{\omega}^{(\alpha)(\beta)}$  are the basis  $\begin{pmatrix} 0 \\ 2 \end{pmatrix}$  tensors.

If the arguments of  $F$  are two arbitrary vectors  $\vec{A}$  and  $\vec{B}$ , eq. (4.7) gives

$$F(\vec{A}, \vec{B}) = F_{\alpha\beta} \tilde{\omega}^{(\alpha)(\beta)}(\vec{A}, \vec{B}). \quad (4.8)$$

On the other hand, since  $A^\alpha = \tilde{\omega}^{(\alpha)}(\vec{A})$  and  $B^\beta = \tilde{\omega}^{(\beta)}(\vec{B})$ , eq. (4.6) gives

$$F(\vec{A}, \vec{B}) = F_{\alpha\beta} \tilde{\omega}^{(\alpha)}(\vec{A}) \tilde{\omega}^{(\beta)}(\vec{B}), \quad (4.9)$$

and, by equating eqs. (4.8) and (4.9) we find

$$\tilde{\omega}^{(\alpha)(\beta)}(\vec{A}, \vec{B}) = \tilde{\omega}^{(\alpha)}(\vec{A}) \tilde{\omega}^{(\beta)}(\vec{B}).$$

The previous equation holds for **any** two vectors  $\vec{A}$  and  $\vec{B}$ , consequently we write

$$\tilde{\omega}^{(\alpha)(\beta)} = \tilde{\omega}^{(\alpha)} \otimes \tilde{\omega}^{(\beta)}, \quad (4.10)$$

where the symbol  $\otimes$  indicates the “outer product” of the two basis one-forms, and means precisely that if  $\tilde{\omega}^{(\alpha)(\beta)}$  is applied to the vectors  $\vec{A}$  and  $\vec{B}$ , the result is a number, which coincides with the number produced by the application of  $\tilde{\omega}^{(\alpha)}$  to  $\vec{A}$  times that produced by the application of  $\tilde{\omega}^{(\beta)}$  to  $\vec{B}$  (the order is important!).

Thus the basis for  $\begin{pmatrix} 0 \\ 2 \end{pmatrix}$  tensors can be constructed by taking the outer product of the basis one-forms. Finally, we can write

$$F = F_{\alpha\beta} \tilde{\omega}^{(\alpha)} \otimes \tilde{\omega}^{(\beta)}. \quad (4.11)$$

It is now clear that we can construct any sort of tensors using the procedure that we have developed in the previous pages. Thus for example a  $\begin{pmatrix} 2 \\ 0 \end{pmatrix}$  tensor  $T(\tilde{\alpha}, \tilde{\sigma})$  is a function that associates to two one-forms  $\tilde{\alpha}$  and  $\tilde{\sigma}$  a number.

The components of this tensor are found by applying  $T$  to the basis one-forms

$$T^{jk} = T(\tilde{\omega}^{(j)}, \tilde{\omega}^{(k)}), \quad (4.12)$$

and the number produced when  $T$  is applied to any two one-forms  $\tilde{\alpha}$ ,  $\tilde{\sigma}$  will be

$$T(\tilde{\alpha}, \tilde{\sigma}) = T(\alpha_j \tilde{\omega}^{(j)}, \sigma_k \tilde{\omega}^{(k)}) = \alpha_j \sigma_k T(\tilde{\omega}^{(j)}, \tilde{\omega}^{(k)}) = \alpha_j \sigma_k T^{jk}, \quad (4.13)$$

where again use has been made of the linearity of tensors with respect to their arguments. By following the same procedure used to find the basis for a  $\begin{pmatrix} 0 \\ 2 \end{pmatrix}$  tensor, it is easy to show

that and the basis appropriate for a  $\begin{pmatrix} 2 \\ 0 \end{pmatrix}$  tensor will be

$$e_{(\alpha)(\beta)} = \vec{e}_\alpha \otimes \vec{e}_\beta, \quad (4.14)$$

and consequently

$$T = T^{\alpha\beta} \vec{e}_\alpha \otimes \vec{e}_\beta. \quad (4.15)$$

Exercise: prove that the  $\begin{pmatrix} 1 \\ 1 \end{pmatrix}$  tensor  $\vec{V} \otimes \tilde{\sigma}$  has components  $V^j \sigma_j$  and find the basis for  $\begin{pmatrix} 1 \\ 1 \end{pmatrix}$  tensors.

Now we ask the following question: how do the components of a tensor transform if we make a coordinate transformation?

We start with a  $\begin{pmatrix} 0 \\ 2 \end{pmatrix}$  tensor

$$F = F_{\alpha\beta} \tilde{\omega}^{(\alpha)} \otimes \tilde{\omega}^{(\beta)} \quad (4.16)$$

If we change coordinates, we shall have a new set of basis one forms  $\{\tilde{\omega}^{(\alpha')}\}$  which are related to the old ones by the equations

$$\tilde{\omega}^{(i)} = \Lambda^i_{k'} \tilde{\omega}^{(k')} \quad , \quad \tilde{\omega}^{(i')} = \Lambda^{i'}_k \tilde{\omega}^k \quad (4.17)$$

In the new basis the tensor  $\begin{pmatrix} 0 \\ 2 \end{pmatrix}$  will be

$$F = F_{\alpha'\beta'} \tilde{\omega}^{(\alpha')} \otimes \tilde{\omega}^{(\beta')} \quad (4.18)$$

By equating (4.16) and (4.18)

$$F_{\alpha'\beta'} \tilde{\omega}^{(\alpha')} \otimes \tilde{\omega}^{(\beta')} = F_{\alpha\beta} \tilde{\omega}^{(\alpha)} \otimes \tilde{\omega}^{(\beta)}.$$

Replacing  $\tilde{\omega}^{(\alpha)}$  and  $\tilde{\omega}^{(\beta)}$  by using the first of eqs. 4.17

$$F_{\alpha'\beta'} \tilde{\omega}^{(\alpha')} \otimes \tilde{\omega}^{(\beta')} = F_{\alpha\beta} \Lambda^\alpha_{k'} \tilde{\omega}^{(k')} \otimes \Lambda^\beta_{i'} \tilde{\omega}^{(i')} = F_{\alpha\beta} \Lambda^\alpha_{k'} \Lambda^\beta_{i'} \tilde{\omega}^{(k')} \otimes \tilde{\omega}^{(i')},$$

or by relabelling the dummy indices

$$F_{k'i'} \tilde{\omega}^{(k')} \otimes \tilde{\omega}^{(i')} = F_{\alpha\beta} \Lambda^\alpha_{k'} \Lambda^\beta_{i'} \tilde{\omega}^{(k')} \otimes \tilde{\omega}^{(i')},$$

and finally

$$F_{k'i'} = F_{\alpha\beta} \Lambda^\alpha_{k'} \Lambda^\beta_{i'}, \quad (4.19)$$

or, by writing explicitly the elements of the matrix  $\Lambda^\alpha_{k'}$

$$F_{k'i'} = F_{\alpha\beta} \frac{\partial x^\alpha}{\partial x^{k'}} \frac{\partial x^\beta}{\partial x^{i'}}, \quad (4.20)$$

where  $\{x^{i'}\}$  are the new coordinates.

In a similar way, by using eqs. 3.37 and 3.39 we would find that

$$T^{k'i'} = T^{\alpha\beta} \Lambda^{k'}_\alpha \Lambda^{i'}_\beta, \quad (4.21)$$

and

$$T^{k'i'} = T^\alpha_\beta \Lambda^{k'}_\alpha \Lambda^\beta_{i'} \quad (4.22)$$

### IMPORTANT

The following point should be stressed: the notion of a tensor that we have introduced is independent on which coordinates, i.e. which basis, we use.

In fact the number that an  $\begin{pmatrix} N \\ N' \end{pmatrix}$  tensor associates to  $N$  one-forms and  $N'$  vectors does not depend on the particular basis we choose.

This is the reason why, for example, we can equate (4.16) and (4.18).

The operations that we are allowed to make with tensors are the following. Given a tensor  $\mathbf{T}$  and its components  $\{T^i_{j..}\}$  on some basis, we can multiply each component by a number

$a$  and find  $\{aT_{j\cdots}^i\}$ . These are the components of the tensor  $\mathbf{aT}$  of the same type. Further operations are

1) Addition and subtraction of tensors of the same type

$$T + G = W \quad \rightarrow \quad T_{\alpha\beta} + G_{\alpha\beta} = W_{\alpha\beta}$$

2) If we multiply the components of two tensors, we find a tensor whose type is the sum of the two

$$\begin{aligned} G^{\alpha\beta} \cdot T_{k\delta} &= W^{\alpha\beta}_{k\delta} \\ \begin{pmatrix} 2 \\ 0 \end{pmatrix} \cdot \begin{pmatrix} 0 \\ 2 \end{pmatrix} &= \begin{pmatrix} 2 \\ 2 \end{pmatrix} \\ G_{\alpha\beta} \cdot T_{k\delta} &= W_{\alpha\beta k\delta} \\ \begin{pmatrix} 0 \\ 2 \end{pmatrix} \cdot \begin{pmatrix} 0 \\ 2 \end{pmatrix} &= \begin{pmatrix} 0 \\ 4 \end{pmatrix} \end{aligned}$$

3) We can contract a pair of indices one of which is up, the other down. The result is a tensor of type  $\begin{pmatrix} N-1 \\ N'-1 \end{pmatrix}$

$$G^{\alpha\beta\gamma}_{\alpha ki} = G^{0\beta\gamma}_{0ki} + G^{1\beta\gamma}_{1ki} + G^{2\beta\gamma}_{2ki} + \dots + G^{n\beta\gamma}_{nki} = G^{\beta\gamma}_{ki}$$

These are called *tensor operations* and an equation involving tensor components and tensor operations is a *tensor equation*.

## 4.2 Symmetries

A  $\begin{pmatrix} 0 \\ 2 \end{pmatrix}$  tensor is **Symmetric** if

$$F(\vec{A}, \vec{B}) = F(\vec{B}, \vec{A}) \quad \forall \vec{A}, \vec{B}. \quad (4.23)$$

As a consequence of eq. (4.6) we see that if the tensor is symmetric

$$F_{\alpha\beta} A^\alpha B^\beta = F_{\alpha\beta} B^\alpha A^\beta, \quad (4.24)$$

and, by relabelling the indices on the RHS

$$F_{\alpha\beta} A^\alpha B^\beta = F_{\beta\alpha} B^\beta A^\alpha, \quad (4.25)$$

i.e.

$$F_{\alpha\beta} = F_{\beta\alpha} \quad (4.26)$$

i.e. if a  $\begin{pmatrix} 0 \\ 2 \end{pmatrix}$  tensor is symmetric the matrix representing its components is symmetric.

Given any  $\begin{pmatrix} 0 \\ 2 \end{pmatrix}$  tensor  $F$  we can always construct from it a symmetric tensor  $F_{(s)}$

$$F^{(s)}(\vec{A}, \vec{B}) = \frac{1}{2}[F(\vec{A}, \vec{B}) + F(\vec{B}, \vec{A})]. \quad (4.27)$$

In fact  $\forall \vec{A}, \vec{B}$

$$\frac{1}{2}[F(\vec{A}, \vec{B}) + F(\vec{B}, \vec{A})] = \frac{1}{2}[F(\vec{B}, \vec{A}) + F(\vec{A}, \vec{B})].$$

Moreover

$$F^{(s)}(\vec{A}, \vec{A}) = F^{(s)\alpha\beta} A^\alpha A^\beta = \frac{1}{2}[F_{\alpha\beta} + F_{\beta\alpha}] A^\alpha A^\beta,$$

and consequently the components of the symmetric tensor are

$$F^{(s)\alpha\beta} = \frac{1}{2}[F_{\alpha\beta} + F_{\beta\alpha}]. \quad (4.28)$$

The components of a symmetric tensor are often indicated as

$$F_{(\alpha\beta)} = \frac{1}{2}[F_{\alpha\beta} + F_{\beta\alpha}]. \quad (4.29)$$

A  $\begin{pmatrix} 0 \\ 2 \end{pmatrix}$  tensor is **antisymmetric** if

$$F(\vec{A}, \vec{B}) = -F(\vec{B}, \vec{A}) \quad \forall \vec{A}, \vec{B}, \quad \text{i.e.} \quad F_{\alpha\beta} = -F_{\beta\alpha}. \quad (4.30)$$

Again from any  $\begin{pmatrix} 0 \\ 2 \end{pmatrix}$  tensor we can construct an antisymmetric tensor  $F^{(a)}$  defined as

$$F^{(a)}(\vec{A}, \vec{B}) = \frac{1}{2}[F(\vec{A}, \vec{B}) - F(\vec{B}, \vec{A})].$$

Proceeding as before, we find that its components are

$$F^{(a)\alpha\beta} = \frac{1}{2}[F_{\alpha\beta} - F_{\beta\alpha}],$$

also indicated as

$$F^{[\alpha\beta]} = \frac{1}{2}[F_{\alpha\beta} - F_{\beta\alpha}]. \quad (4.31)$$

It is clear that any tensor  $\begin{pmatrix} 0 \\ 2 \end{pmatrix}$  can be written as the sum of its symmetric and antisymmetric part

$$h[\vec{A}, \vec{B}] = \frac{1}{2}[h(\vec{A}, \vec{B}) + h(\vec{B}, \vec{A})] + \frac{1}{2}[h(\vec{A}, \vec{B}) - h(\vec{B}, \vec{A})] = h(\vec{A}, \vec{B}).$$

### 4.3 The metric Tensor

In chapter I we have seen that the metric tensor occupies a central role in the relativistic theory of gravity. In this section we shall discuss its geometrical meaning.

Definition: *the metric tensor  $\mathbf{g}$  is a  $\begin{pmatrix} 0 \\ 2 \end{pmatrix}$  tensor that, having two arbitrary vectors  $\vec{A}$  and  $\vec{B}$  as arguments, associates to them a real number that is the **inner product** (or scalar product)  $\vec{A} \cdot \vec{B}$*

$$g(\vec{A}, \vec{B}) = \vec{A} \cdot \vec{B}. \quad (4.32)$$

The scalar product is usually defined to be a linear function of two vectors that satisfies the following properties

$$\begin{aligned}\vec{U} \cdot \vec{V} &= \vec{V} \cdot \vec{U} \\ (a\vec{U}) \cdot \vec{V} &= a(\vec{U} \cdot \vec{V}) \\ (\vec{U} + \vec{V}) \cdot \vec{W} &= \vec{U} \cdot \vec{W} + \vec{V} \cdot \vec{W}\end{aligned}\tag{4.33}$$

From the first eq. (4.33) it follows that  $\mathbf{g}$  is a symmetric tensor. In fact

$$\vec{U} \cdot \vec{V} = g(\vec{U}, \vec{V}) = \vec{V} \cdot \vec{U} = g(\vec{V}, \vec{U}), \quad \rightarrow \quad g(\vec{U}, \vec{V}) = g(\vec{V}, \vec{U}).\tag{4.34}$$

The second and third eqs. (4.33) imply that  $\mathbf{g}$  is a linear functions of the arguments, a condition which is automatically satisfied since  $\mathbf{g}$  is a tensor.

As usual the components of the metric tensor are obtained by replacing  $\vec{A}$  and  $\vec{B}$  with the basis vectors

$$g_{\alpha\beta} = g(\vec{e}_{(\alpha)}, \vec{e}_{(\beta)}).\tag{4.35}$$

Thus the metric tensor allows to compute the scalar product of two vectors in any space and whatever coordinates we use:

$$\begin{aligned}\vec{A} \cdot \vec{B} = g(\vec{A}, \vec{B}) &= g(A^\alpha \vec{e}_{(\alpha)}, B^\beta \vec{e}_{(\beta)}) = A^\alpha B^\beta g(\vec{e}_{(\alpha)}, \vec{e}_{(\beta)}) = \\ &A^\alpha B^\beta g_{\alpha\beta}.\end{aligned}\tag{4.36}$$

## EXAMPLES

1)

We want to show that the metric of Minkowski spacetime is

$$g_{\alpha\beta} = \begin{pmatrix} -1 & 0 & 0 & 0 \\ 0 & +1 & 0 & 0 \\ 0 & 0 & +1 & 0 \\ 0 & 0 & 0 & +1 \end{pmatrix} \equiv \eta_{\alpha\beta}$$

In fact, given the basis vector

$$\begin{aligned}\vec{e}_{(0)} &= \vec{e}_t \rightarrow (1, 0, 0, 0) \\ \vec{e}_{(1)} &= \vec{e}_x \rightarrow (0, 1, 0, 0) \\ \vec{e}_{(2)} &= \vec{e}_y \rightarrow (0, 0, 1, 0) \\ \vec{e}_{(3)} &= \vec{e}_z \rightarrow (0, 0, 0, 1)\end{aligned}$$

we know that they are mutually orthogonal, i.e.

$$\vec{e}_{(\alpha)} \cdot \vec{e}_{(\beta)} = 0 \quad \text{if} \quad \alpha \neq \beta.$$

It follows that

$$g_{(\alpha\beta)} = 0 \quad \text{if} \quad \alpha \neq \beta.$$

In addition the basis vector are unit vectors, i.e.

$$\vec{e}_{(k)} \cdot \vec{e}_{(k)} = 1 \quad \text{if} \quad k = 1, 3,$$

and

$$\vec{e}_{(0)} \cdot \vec{e}_{(0)} = -1$$

since  $\vec{e}_{(0)}$  is a timelike vector. Consequently

$$g_{ii} = 1, \quad \text{and} \quad g_{00} = -1.$$

q.e.d.

From now on we shall call  $\eta_{\alpha\beta}$  the components of the metric tensor of the Minkowski spacetime when expressed in cartesian coordinates.

2)

We now want to compute how the components of the metric tensor change if we change the coordinate system. We shall answer this question in two ways

a) by using the expressions of the new basis vectors and eq. (4.35)

b) by using the transformation law (4.19).

a)

For simplicity let us consider, as we did in the example in section 3.4, a 3-dimensional spacetime, and suppress the coordinate  $z$ .

$$\vec{e}_{(0)} \rightarrow (1, 0, 0)$$

$$\vec{e}_{(1)} \rightarrow (0, 1, 0)$$

$$\vec{e}_{(2)} \rightarrow (0, 0, 1)$$

$$g_{ik} = \begin{pmatrix} -1 & 0 & 0 \\ 0 & +1 & 0 \\ 0 & 0 & +1 \end{pmatrix} \equiv \eta_{ik} \quad i = k = 0, 2,$$

and

$$\vec{e}_{(i)} \cdot \vec{e}_{(k)} = 0 \quad \text{if} \quad i \neq k$$

$$\vec{e}_{(0)} \cdot \vec{e}_{(0)} = -1$$

$$\vec{e}_{(1)} \cdot \vec{e}_{(1)} = +1 = \vec{e}_{(2)} \cdot \vec{e}_{(2)}.$$

We now change to polar coordinates

$$x^0 = x^{0'}, \quad x^1 = r \cos \theta, \quad x^2 = r \sin \theta. \quad (4.37)$$

The new basis vectors computed in sec. 3.4 are

$$\vec{e}_{(0')} = \vec{e}_{(0)} \quad (4.38)$$

$$\vec{e}_{(1')} = \vec{e}_{(r)} = \cos \theta \vec{e}_{(1)} + \sin \theta \vec{e}_{(2)} \quad (4.39)$$

$$\vec{e}_{(2')} = \vec{e}_{(\theta)} = -r \sin \theta \vec{e}_{(1)} + r \cos \theta \vec{e}_{(2)}.$$

Consequently

$$\begin{aligned}
g_{0'0'} &= \vec{e}_{(0')} \cdot \vec{e}_{(0')} = \vec{e}_{(0)} \cdot \vec{e}_{(0)} = -1 \\
g_{0'i'} &= 0 \quad i' = 1, 2 \\
g_{1'1'} &= \vec{e}_{(1')} \cdot \vec{e}_{(1')} = (\cos \theta \vec{e}_{(1)} + \sin \theta \vec{e}_{(2)}) \cdot (\cos \theta \vec{e}_{(1)} + \sin \theta \vec{e}_{(2)}) = \cos^2 \theta + \sin^2 \theta = 1 \\
g_{2'2'} &= \vec{e}_{(2')} \cdot \vec{e}_{(2')} = +r^2 \sin^2 \theta + r^2 \cos^2 \theta = r^2 \\
g_{1'2'} &= -r \cos \theta \sin \theta + r \cos \theta \sin \theta = 0
\end{aligned}$$

$$g_{i'k'} = \begin{pmatrix} -1 & 0 & 0 \\ 0 & +1 & 0 \\ 0 & 0 & r^2 \end{pmatrix}. \quad (4.40)$$

b) Let us now use the transformation law

$$g_{i'k'} = \Lambda^\alpha{}_{i'} \Lambda^\beta{}_{k'} g_{ik} = \Lambda^\alpha{}_{i'} \Lambda^\beta{}_{k'} \eta_{\alpha\beta}$$

Since  $\eta_{ik}$  is diagonal we only need to consider  $\alpha = \beta$ .

$$g_{0'0'} = \Lambda^\alpha{}_{0'} \Lambda^\alpha{}_{0'} \eta_{\alpha\alpha} = \left( \frac{\partial x^\alpha}{\partial x^{0'}} \right)^2 \eta_{\alpha\alpha} = \left( \frac{\partial x^0}{\partial x^{0'}} \right)^2 \eta_{00} = 1 \cdot (-1) = -1$$

$$g_{0'i'} = \Lambda^\alpha{}_{0'} \Lambda^\alpha{}_{i'} \eta_{\alpha\alpha} = \frac{\partial x^0}{\partial x^{0'}} \frac{\partial x^0}{\partial x^{i'}} \eta_{00} + \frac{\partial x^1}{\partial x^{0'}} \frac{\partial x^1}{\partial x^{i'}} \eta_{11} + \frac{\partial x^2}{\partial x^{0'}} \frac{\partial x^2}{\partial x^{i'}} \eta_{22} = 0 \quad i' = 1, 2$$

because  $\frac{\partial x^0}{\partial x^{i'}} = \frac{\partial x^1}{\partial x^{0'}} = \frac{\partial x^2}{\partial x^{0'}} = 0$ .

$$\begin{aligned}
g_{1'1'} &= \Lambda^\alpha{}_{1'} \Lambda^\alpha{}_{1'} \eta_{\alpha\alpha} = (\Lambda^0{}_{1'})^2 \eta_{00} + (\Lambda^1{}_{1'})^2 \eta_{11} + (\Lambda^2{}_{1'})^2 \eta_{22} = \\
&= \left( \frac{\partial x^0}{\partial x^{1'}} \right)^2 \cdot (-1) + \left( \frac{\partial x^1}{\partial x^{1'}} \right)^2 \cdot 1 + \left( \frac{\partial x^2}{\partial x^{1'}} \right)^2 \cdot 1 = \left( \frac{\partial x}{\partial r} \right)^2 + \left( \frac{\partial y}{\partial r} \right)^2
\end{aligned}$$

$$g_{1'1'} = \cos^2 \theta + \sin^2 \theta = 1$$

Proceeding in this way we clearly find again the metric (4.40) in the new frame  $(x^{0'}, x^{1'}, x^{2'}) = (ct, r, \theta)$ .

### 4.3.1 The metric tensor allows to compute the distance between two points

Let us consider, for example, a three-dimensional space.

$$(x^0, x^1, x^2) \equiv (ct, x, y)$$

The distance between a point  $P(x^0, x^1, x^2)$  and  $P'(x^0 + dx^0, x^1 + dx^1, x^2 + dx^2)$  is

$$\vec{ds} = dx^0 \vec{e}_{(0)} + dx^1 \vec{e}_{(1)} + dx^2 \vec{e}_{(2)} = dx^\alpha \vec{e}_{(\alpha)} \quad (4.41)$$

and  $\vec{e}_{(\alpha)}$  are the basis vectors.  $ds^2$  is the norm of the vector  $\vec{ds}$ , i.e. the square of the distance between  $P$  and  $P'$ :

$$\begin{aligned} ds^2 &= \vec{ds} \cdot \vec{ds} = (dx^0 \vec{e}_{(0)} + dx^1 \vec{e}_{(1)} + dx^2 \vec{e}_{(2)}) \cdot (dx^0 \vec{e}_{(0)} + dx^1 \vec{e}_{(1)} + dx^2 \vec{e}_{(2)}) \\ &= (dx^0)^2 (\vec{e}_{(0)} \cdot \vec{e}_{(0)}) + dx^1 dx^0 (\vec{e}_{(1)} \cdot \vec{e}_{(0)}) + dx^2 dx^0 (\vec{e}_{(2)} \cdot \vec{e}_{(0)}) + \\ &+ dx^0 dx^1 (\vec{e}_{(0)} \cdot \vec{e}_{(1)}) + (dx^1)^2 (\vec{e}_{(1)} \cdot \vec{e}_{(1)}) + dx^2 dx^1 (\vec{e}_{(2)} \cdot \vec{e}_{(1)}) + \\ &+ dx^0 dx^2 (\vec{e}_{(0)} \cdot \vec{e}_{(2)}) + dx^2 dx^1 (\vec{e}_{(2)} \cdot \vec{e}_{(1)}) + (dx^2)^2 (\vec{e}_{(2)} \cdot \vec{e}_{(2)}) \end{aligned}$$

By definition of the metric tensor

$$(\vec{e}_{(i)} \cdot \vec{e}_{(j)}) = g(\vec{e}_{(i)}, \vec{e}_{(j)}) = g_{ij},$$

therefore

$$ds^2 = g(\vec{ds}, \vec{ds}) = (dx^0)^2 g_{00} + 2dx^0 dx^1 g_{01} + 2dx^0 dx^2 g_{02} + 2dx^1 dx^2 g_{12} + (dx^1)^2 g_{11} + (dx^2)^2 g_{22} \quad (4.42)$$

where we have used the fact that  $g_{\alpha\beta} = g_{\beta\alpha}$ .

This calculation is simplified if we use the following notation

$$\begin{aligned} ds^2 = g(\vec{ds}, \vec{ds}) &= g\left(\sum_{\alpha=0}^2 dx^\alpha \vec{e}_{(\alpha)}, \sum_{\beta=0}^2 dx^\beta \vec{e}_{(\beta)}\right) \equiv g(dx^\alpha \vec{e}_{(\alpha)}, dx^\beta \vec{e}_{(\beta)}) = \\ &= dx^\alpha dx^\beta g(\vec{e}_{(\alpha)}, \vec{e}_{(\beta)}) = g_{\alpha\beta} dx^\alpha dx^\beta \end{aligned} \quad (4.43)$$

with  $\alpha, \beta = 0, 2$ .

This way of writing is completely equivalent to eq. (4.42). For example, if the space is Minkowski spacetime  $g_{\alpha\beta} = \eta_{\alpha\beta} = \text{diag}(-1, 1, 1)$ , and eq. (4.43) gives

$$ds^2 = -(dx^0)^2 + (dx^1)^2 + (dx^2)^2, \quad (4.44)$$

as expected.

If we now change to a coordinate system  $(x^{0'}, x^{1'}, x^{2'})$ , the distance  $PP'$  will be  $ds'^2 = ds^2$ , i.e.

$$\begin{aligned} g(\vec{ds}', \vec{ds}') &= \vec{ds}' \cdot \vec{ds}' = ds'^2 = ds^2 = \\ &= g(dx^{\alpha'} \vec{e}_{(\alpha')}, dx^{\beta'} \vec{e}_{(\beta')}) = dx^{\alpha'} dx^{\beta'} g(\vec{e}_{(\alpha')}, \vec{e}_{(\beta')}), \end{aligned}$$

where  $\{\vec{e}_{(\alpha')}\}$  are the new basis vectors. Therefore

$$ds^2 = g_{\alpha'\beta'} dx^{\alpha'} dx^{\beta'} \quad (4.45)$$

where now  $g_{\alpha'\beta'}$  are the components of the metric tensor in the new basis. For example, if we change from cartesian to polar coordinates  $(x^{0'}, x^{1'}, x^{2'}) \equiv (ct, r, \theta)$ ,

$$ds^2 = (dx^{0'})^2 g_{0'0'} + (dx^{1'})^2 g_{1'1'} + (dx^{2'})^2 g_{2'2'} = -(dx^0)^2 + dr^2 + r^2 d\theta^2. \quad (4.46)$$

Thus if we know the components of the metric tensor in any reference frame, we can compute the distance  $ds^2$ .

### 4.3.2 The metric tensor maps vectors into one-forms

As we have seen, the metric tensor is a linear function of two vectors: this means that it takes two vectors and associates a number to them. The number is their scalar product.

But now suppose that we write  $g(\cdot, \vec{V})$ , namely we leave the first slot empty. What is this? We know that if we fill the first slot with a generic vector  $\vec{A}$  we will get a number, thus  $g(\cdot, \vec{V})$  must be a linear function of a generic vector that we can put in the empty slot, and that associates a number to this vector.

But this is the definition of one-forms! Thus  $g(\cdot, \vec{V})$  is a one-form.

In addition, it is a particular one-form because it depends on  $\vec{V}$ : if I change  $\vec{V}$ , the one-form will be different. Let us indicate this one-form as

$$g(\cdot, \vec{V}) = \tilde{V}(\cdot). \quad (4.47)$$

We leave the slot empty because we can put any arbitrary vector into it.

By definition the components of  $\tilde{V}$  are slot

$$V_\alpha = \tilde{V}(\vec{e}_{(\alpha)}) = g(\vec{e}_{(\alpha)}, \vec{V}) = g(\vec{e}_{(\alpha)}, V^\beta \vec{e}_{(\beta)}) = V^\beta g(\vec{e}_{(\alpha)}, \vec{e}_{(\beta)}) = V^\beta g_{\alpha\beta},$$

hence

$$V_\alpha = g_{\alpha\beta} V^\beta. \quad (4.48)$$

Thus the tensor  $g$  associates to any vector  $\vec{V}$  a one-form  $\tilde{V}$ , dual of  $\vec{V}$ , whose components can be computed if we know  $g_{\alpha\beta}$  and  $V^\alpha$ .

In addition, if we multiply eq. (4.48) by  $g^{\alpha\gamma}$ , where  $g^{\alpha\gamma}$  is the matrix inverse to  $g_{\alpha\gamma}$

$$g_{\alpha\gamma} g^{\gamma\beta} = \delta_\alpha^\beta, \quad (4.49)$$

we find

$$g^{\alpha\gamma} V_\alpha = g^{\alpha\gamma} g_{\alpha\beta} V^\beta = \delta_\beta^\gamma V^\beta = V^\gamma,$$

i.e.

$$V^\gamma = g^{\alpha\gamma} V_\alpha, \quad (4.50)$$

Consequently the metric tensor also maps vectors into one-forms. In a similar way the metric tensor can map a  $\begin{pmatrix} 2 \\ 0 \end{pmatrix}$  tensor in a  $\begin{pmatrix} 1 \\ 1 \end{pmatrix}$  tensor

$$A_j^i = g_{jk} A^{ik},$$

or in a  $\begin{pmatrix} 0 \\ 2 \end{pmatrix}$  tensor

$$A_{jl} = g_{jk} g_{ln} A^{kn},$$

or viceversa

$$A^{jl} = g^{jk} g^{ln} A_{kn}.$$

These maps are called index raising and lowering.

Summarizing, the metric tensor

1) allows to compute the inner product of two vectors  $g(\vec{A}, \vec{B}) = \vec{A} \cdot \vec{B}$ , and consequently the norm of a vector  $g(\vec{A}, \vec{A}) = \vec{A} \cdot \vec{A} = A^2$ .

2) As a consequence it allows to compute the distance between two points  $ds^2 = g(\vec{ds}, \vec{ds}) = g_{\alpha\beta} dx^\alpha dx^\beta$ .

3) It maps one-forms into vectors and viceversa.

4) It allows to raise and lower indices.

# Chapter 5

## Affine Connections and Parallel Transport

In chapter I we showed that there are two quantities that describe the effects of a gravitational field on moving bodies by virtue of the Equivalence Principle: the metric tensor and the affine connections. In chapter IV we discussed the geometrical properties of the metric tensor. In this chapter we shall define the affine connections as the quantities that allow to compute the derivative of a vector in an arbitrary space, and we shall show that they coincide with the  $\Gamma$ 's introduced in chapter I.

### 5.1 The covariant derivative of vectors

Be

$$\vec{V} = V^\alpha \vec{e}_{(\alpha)} \quad (5.1)$$

a vector. Is the derivative of  $\vec{V}$ ,  $\frac{\partial \vec{V}}{\partial x^\beta}$ , a vector?

$$\frac{\partial \vec{V}}{\partial x^\beta} = \frac{\partial V^\alpha}{\partial x^\beta} \vec{e}_{(\alpha)} + V^\alpha \frac{\partial \vec{e}_{(\alpha)}}{\partial x^\beta}. \quad (5.2)$$

The first term on the R.H.S. is a linear combination of the basis vectors  $\{\vec{e}_{(\alpha)}\}$ , therefore it is a vector. The term  $\frac{\partial \vec{e}_{(\alpha)}}{\partial x^\beta}$ , is also a vector for the following reason. We can always make

(locally) a coordinate transformation which brings the metric in the form  $\begin{pmatrix} -1 & 0 & 0 & 0 \\ 0 & 1 & 0 & 0 \\ 0 & 0 & 1 & 0 \\ 0 & 0 & 0 & 1 \end{pmatrix}$ ,

and introduce new, constant basis vectors  $\vec{e}_{(\alpha')}$  related to the old basis vectors  $\vec{e}_{(\alpha)}$  by the equation

$$\vec{e}_{(\alpha)} = \Lambda^{\alpha'}_{\alpha} \vec{e}_{(\alpha')}. \quad (5.3)$$

Consequently

$$\frac{\partial \vec{e}_{(\alpha)}}{\partial x^\beta} = \left( \frac{\partial}{\partial x^\beta} \Lambda^{\alpha'}_{\alpha} \right) \vec{e}_{(\alpha')},$$

and since the R.H.S. is a linear combination of vectors,  $\frac{\partial \vec{e}_{(\alpha)}}{\partial x^\beta}$  is a vector. Q.E.D.

Since  $\frac{\partial \vec{e}_{(\alpha)}}{\partial x^\beta}$  is a vector, we must be able to express it as a linear combination of the basis vectors  $\{\vec{e}_{(\mu)}\}$  we are working with, i.e.:

$$\frac{\partial \vec{e}_{(\alpha)}}{\partial x^\beta} = \Gamma_{\alpha\beta}^\mu \vec{e}_{(\mu)}, \quad (5.4)$$

where the constants  $\Gamma_{\alpha\beta}^\mu$  have three indices because  $\alpha$  indicates which basis vector  $\vec{e}_{(\alpha)}$  we are differentiating, and  $\beta$  indicates the coordinate with respect to which the differentiation is performed. The  $\Gamma_{\beta\alpha}^\mu$  are called **affine connection** or **Christoffel symbols**.

Thus, the derivative of  $\vec{V}$  in eq. (5.2) becomes

$$\frac{\partial \vec{V}}{\partial x^\beta} = \frac{\partial V^\alpha}{\partial x^\beta} \vec{e}_{(\alpha)} + V^\alpha \Gamma_{\beta\alpha}^\mu \vec{e}_{(\mu)},$$

or relabelling the dummy indices

$$\frac{\partial \vec{V}}{\partial x^\beta} = \left[ \frac{\partial V^\alpha}{\partial x^\beta} + V^\sigma \Gamma_{\beta\sigma}^\alpha \right] \vec{e}_{(\alpha)}. \quad (5.5)$$

For any fixed  $\beta$ ,  $\frac{\partial \vec{V}}{\partial x^\beta}$  is a vector field because it is a linear combination of the basis vectors  $\{\vec{e}_{(\alpha)}\}$  with coefficients  $\left[ \frac{\partial V^\alpha}{\partial x^\beta} + V^\sigma \Gamma_{\beta\sigma}^\alpha \right]$ . If we introduce the following notation

$$V^\alpha{}_{;\beta} = \frac{\partial V^\alpha}{\partial x^\beta}, \quad \text{and} \quad V^\alpha{}_{;\beta} = \frac{\partial V^\alpha}{\partial x^\beta} + V^\mu \Gamma_{\beta\mu}^\alpha, \quad (5.6)$$

eq. (5.5) becomes

$$\frac{\partial \vec{V}}{\partial x^\beta} = V^\alpha{}_{;\beta} \vec{e}_{(\alpha)}. \quad (5.7)$$

### 5.1.1 $V^\alpha{}_{;\beta}$ are the components of a tensor

Let us define the following quantity:

$$\nabla \vec{V} = \left[ V^\alpha{}_{;\beta} \vec{e}_{(\alpha)} \right] \otimes \tilde{\omega}^{(\beta)}. \quad (5.8)$$

As shown in section 5.1, for any fixed value of  $\beta$  the quantity  $\left[ V^\alpha{}_{;\beta} \vec{e}_{(\alpha)} \right]$  is a vector; thus,  $\nabla \vec{V}$  defined in eq. (5.8) is the outer product between these vectors and the basis one-forms, i.e. it is a  $\begin{pmatrix} 1 \\ 1 \end{pmatrix}$  tensor. This tensor field is called **Covariant derivative of a vector**, and its components are

$$(\nabla \vec{V})^\alpha{}_\beta \equiv \nabla_\beta V^\alpha \equiv V^\alpha{}_{;\beta}. \quad (5.9)$$

#### NOTE THAT

In a locally inertial frame the basis vectors are constant, and consequently, according to eq. (5.4) the affine connections vanish and from eq. (5.6) it follows that

$$V^\alpha{}_{;\beta} = V^\alpha{}_{,\beta} \implies \frac{\partial \vec{V}}{\partial x^\beta} = V^\alpha{}_{,\beta} \vec{e}_{(\alpha)}. \quad (5.10)$$

**Thus, in a locally inertial frame covariant and ordinary derivative coincide.**

In this chapter we have introduced the connections as those quantities that allow to find the covariant derivative of a vector in an arbitrary frame. How can we compute  $\Gamma_{\alpha\beta}^{\mu}$  from what we know? Remember that the equation which defines  $\Gamma_{\alpha\beta}^{\mu}$  is

$$\frac{\partial \vec{e}_{(\alpha)}}{\partial x^{\beta}} = \Gamma_{\alpha\beta}^{\mu} \vec{e}_{(\mu)}. \quad (5.11)$$

Let us consider for example a 2-dimensional flat space in polar coordinates, i.e.  $(x^{1'}, x^{2'}) \equiv (r, \theta)$  and remember that the basis vectors are related to the coordinate basis associated to cartesian coordinates by the equations

$$\begin{aligned} \vec{e}_{(1')} &= \cos \theta \vec{e}_{(1)} + \sin \theta \vec{e}_{(2)} \\ \vec{e}_{(2')} &= -r \sin \theta \vec{e}_{(1)} + r \cos \theta \vec{e}_{(2)}. \end{aligned}$$

Let us indicate, for simplicity  $(\vec{e}_{(1)}, \vec{e}_{(2)})$  with  $(\vec{e}_{(x)}, \vec{e}_{(y)})$ , and  $(\vec{e}_{(1')}, \vec{e}_{(2')})$  with  $(\vec{e}_{(r)}, \vec{e}_{(\theta)})$ . From these expressions we find

$$\frac{\partial \vec{e}_{(r)}}{\partial r} = \frac{\partial}{\partial r} (\cos \theta \vec{e}_{(x)} + \sin \theta \vec{e}_{(y)}) = 0,$$

and consequently

$$\Gamma_{rr}^{\mu} \vec{e}_{(\mu)} = \Gamma_{rr}^r \vec{e}_{(r)} + \Gamma_{rr}^{\theta} \vec{e}_{(\theta)} = 0 \implies \Gamma_{rr}^r = \Gamma_{rr}^{\theta} = 0.$$

Moreover

$$\begin{aligned} \frac{\partial \vec{e}_{(r)}}{\partial \theta} &= \frac{\partial}{\partial \theta} (\cos \theta \vec{e}_{(x)} + \sin \theta \vec{e}_{(y)}) = \\ &= -\sin \theta \vec{e}_{(x)} + \cos \theta \vec{e}_{(y)} = \frac{1}{r} \vec{e}_{(\theta)}, \end{aligned}$$

therefore

$$\frac{1}{r} \vec{e}_{(\theta)} = \Gamma_{r\theta}^{\mu} \vec{e}_{(\mu)} = \Gamma_{r\theta}^r \vec{e}_{(r)} + \Gamma_{r\theta}^{\theta} \vec{e}_{(\theta)} \implies \Gamma_{r\theta}^r = 0, \quad \Gamma_{r\theta}^{\theta} = \frac{1}{r}.$$

Proceeding along these lines one can show that

$$\Gamma_{\theta r}^r = 0, \quad \Gamma_{\theta r}^{\theta} = \frac{1}{r}, \quad \Gamma_{\theta\theta}^r = -r, \quad \Gamma_{\theta\theta}^{\theta} = 0.$$

It should be noted that although we have used the cartesian basis to express  $\vec{e}_{(r)}$  and  $\vec{e}_{(\theta)}$  and compute their derivatives, at the end the  $\Gamma$ 's depend only on the coordinates  $r$  and  $\theta$ .

## 5.2 The covariant derivative of one-forms and tensors

In order to find the covariant derivative of a one-form consider a scalar  $\Phi$  field. At any point of space it is a number, therefore it does not depend on the coordinate basis: this implies that ordinary and covariant derivative coincide

$$\nabla_\mu \Phi = \frac{\partial \Phi}{\partial x^\mu} = (d\tilde{\Phi})_\mu. \quad (5.12)$$

Now remember the definition of a one-form: it is a linear function that takes a vector and associates to it a number according to the rule

$$\tilde{q}(\vec{V}) = q_j V^j, \quad (5.13)$$

where  $q_j$  and  $V^j$  are the components of the one-form and of the vector. We can therefore assume that the scalar function  $\Phi$  is

$$\Phi = q_j V^j, \quad (5.14)$$

and consequently the covariant derivative will be

$$\nabla_\mu \Phi \equiv \frac{\partial \Phi}{\partial x^\mu} = \frac{\partial q_j}{\partial x^\mu} V^j + q_j \frac{\partial V^j}{\partial x^\mu}.$$

Substituting  $\frac{\partial V^j}{\partial x^\mu}$  from eq. (5.6) we find

$$\nabla_\mu \Phi = \frac{\partial q_j}{\partial x^\mu} V^j + q_j [V^j{}_{;\mu} - V^k \Gamma_{\mu k}^j].$$

We relabel the indices to put  $V^j$  in evidence

$$\begin{aligned} \nabla_\mu \Phi &= \frac{\partial q_j}{\partial x^\mu} V^j + q_k V^k{}_{;\mu} - q_k V^j \Gamma_{\mu j}^k = \\ &= \left[ \frac{\partial q_j}{\partial x^\mu} - q_k \Gamma_{\mu j}^k \right] V^j + q_k V^k{}_{;\mu}. \end{aligned} \quad (5.15)$$

$\nabla_\mu \Phi$  are the components of a tensor ( $\nabla_\mu \Phi \equiv d\tilde{\Phi}_\mu$ ) as well as  $V^j$ ,  $q_k$  and  $V^k{}_{;\mu}$ <sup>1</sup>. Therefore in order this equation to be true, also the terms in parenthesis must be the components of a tensor. We call **covariant derivative of the one-form**  $\tilde{q}$  a  $\begin{pmatrix} 0 \\ 2 \end{pmatrix}$  tensor  $\nabla \tilde{q}$  whose components are

$$(\nabla \tilde{q})_{\alpha\beta} \equiv \nabla_\beta \tilde{q}_\alpha = q_{\alpha;\beta} = q_{\alpha,\beta} - q_k \Gamma_{\beta\alpha}^k. \quad (5.16)$$

We now observe that eq. (5.15) can be written as

$$\nabla_\mu \Phi = \nabla_\mu (q_\alpha V^\alpha) = q_{\alpha;\mu} V^\alpha + q_\alpha V^\alpha{}_{;\mu}. \quad (5.17)$$

---

<sup>1</sup>here we use the word ‘tensor’ to indicate any type of tensors, included vectors and one-forms

From this equation it follows that the covariant derivative satisfies the usual property of a derivative of a product.

The same procedure that led to define the covariant derivative of one-forms can be used to define the covariant derivative of  $\begin{pmatrix} N \\ N' \end{pmatrix}$  tensors.

(do it as an exercise)

$$(\nabla T_{\mu\nu})_{\beta} = T_{\mu\nu,\beta} - T_{\alpha\nu}\Gamma_{\beta\mu}^{\alpha} - T_{\mu\alpha}\Gamma_{\beta\nu}^{\alpha} \quad (5.18)$$

$$(\nabla A^{\mu\nu})_{\beta} = A^{\mu\nu},_{\beta} + A^{\alpha\nu}\Gamma_{\alpha\beta}^{\mu} + A^{\mu\alpha}\Gamma_{\alpha\beta}^{\nu} \quad (5.19)$$

$$(\nabla B^{\mu}{}_{\nu})_{\beta} = B^{\mu}{}_{\nu,\beta} + B^{\alpha}{}_{\nu}\Gamma_{\beta\alpha}^{\mu} - B^{\mu}{}_{\alpha}\Gamma_{\beta\nu}^{\alpha} \quad (5.20)$$

what is the rule?

### 5.3 The covariant derivative of the metric tensor

The covariant derivative of  $g_{\mu\nu}$  is zero

$$g_{\mu\nu;\alpha} = 0.$$

The reason is the following. We know from the principle of equivalence that at each point of spacetime we can choose a coordinate system such that  $g_{\mu\nu}$  reduces to  $\eta_{\mu\nu}$ . The coordinate basis associated to these coordinates has constant basis vectors, therefore the affine connections also vanish (see eq. 5.4). In this frame

$$g_{\alpha\beta;\mu} = \eta_{\alpha\beta;\mu} = \frac{\partial \eta_{\alpha\beta}}{\partial x^{\mu}} - \Gamma_{\alpha\mu}^{\nu} g_{\nu\beta} - \Gamma_{\beta\mu}^{\nu} g_{\alpha\nu} = 0$$

$g_{\alpha\beta;\mu}$  is a  $\begin{pmatrix} 0 \\ 3 \end{pmatrix}$  tensor, and if all components of a tensor are zero in a coordinate system, they are zero in **any** coordinate system therefore

$$g_{\alpha\beta;\mu} = 0 \quad (5.21)$$

always.

### 5.4 Symmetries of the affine connections

Consider an arbitrary scalar field  $\Phi$ .

Its first covariant derivative is a one-form and coincides with the ordinary derivative. Its second covariant derivative  $\nabla\nabla\Phi$  is a  $\begin{pmatrix} 0 \\ 2 \end{pmatrix}$  tensor of components  $\Phi_{,\beta;\alpha}$ . In Minkowskian coordinates, i.e. in a locally inertial frame, covariant derivative reduces to ordinary derivative:

$$\Phi_{,\beta;\alpha} = \Phi_{,\beta,\alpha} = \frac{\partial}{\partial x^{\alpha}} \frac{\partial}{\partial x^{\beta}} \Phi, \quad (5.22)$$

and since partial derivatives commute

$$\Phi_{,\beta,\alpha} = \Phi_{,\alpha,\beta} \Rightarrow \Phi_{,\beta;\alpha} = \Phi_{,\alpha;\beta}. \quad (5.23)$$

Thus, the tensor  $\nabla\nabla\Phi$  is symmetric. But if a tensor is symmetric in one basis, it is symmetric in any basis, therefore

$$\Phi_{,\beta,\alpha} - \Phi_{,\mu}\Gamma_{\beta\alpha}^{\mu} = \Phi_{,\alpha,\beta} - \Phi_{,\mu}\Gamma_{\alpha\beta}^{\mu}$$

in any coordinate system. It follows that for any  $\Phi$

$$\Phi_{,\mu}\Gamma_{\beta\alpha}^{\mu} = \Phi_{,\mu}\Gamma_{\alpha\beta}^{\mu},$$

and consequently

$$\Gamma_{\beta\alpha}^{\mu} = \Gamma_{\alpha\beta}^{\mu} \quad (5.24)$$

in any coordinate system. Q.E.D.

## 5.5 The relation between the affine connections and the metric tensor

From eq. (5.21) it follows that

$$g_{\alpha\beta;\mu} = g_{\alpha\beta,\mu} - \Gamma_{\alpha\mu}^{\nu}g_{\nu\beta} - \Gamma_{\beta\mu}^{\nu}g_{\alpha\nu} = 0,$$

therefore

$$g_{\alpha\beta,\mu} = \Gamma_{\alpha\mu}^{\nu}g_{\nu\beta} + \Gamma_{\beta\mu}^{\nu}g_{\alpha\nu}. \quad (5.25)$$

Let us now consider the following equations

$$\begin{aligned} g_{\alpha\mu,\beta} &= \Gamma_{\alpha\beta}^{\nu}g_{\nu\mu} + \Gamma_{\mu\beta}^{\nu}g_{\alpha\nu}, \\ -g_{\beta\mu,\alpha} &= -\Gamma_{\beta\alpha}^{\nu}g_{\nu\mu} - \Gamma_{\mu\alpha}^{\nu}g_{\beta\nu}, \end{aligned}$$

It follows that

$$\begin{aligned} g_{\alpha\beta,\mu} + g_{\alpha\mu,\beta} - g_{\beta\mu,\alpha} &= (\Gamma_{\alpha\mu}^{\nu} - \Gamma_{\mu\alpha}^{\nu})g_{\nu\beta} + \\ &+ (\Gamma_{\beta\mu}^{\nu} + \Gamma_{\mu\beta}^{\nu})g_{\alpha\nu} + (\Gamma_{\alpha\beta}^{\nu} - \Gamma_{\beta\alpha}^{\nu})g_{\nu\mu}, \end{aligned}$$

where we have used  $g_{\alpha\beta} = g_{\beta\alpha}$ .

Since  $\Gamma_{\beta\gamma}^{\alpha}$  are symmetric in  $\beta$  and  $\gamma$ , it follows that

$$g_{\alpha\beta,\mu} + g_{\alpha\mu,\beta} - g_{\beta\mu,\alpha} = 2\Gamma_{\beta\mu}^{\nu}g_{\alpha\nu}.$$

If we multiply by  $g^{\alpha\gamma}$  and remember that since  $g^{\alpha\gamma}$  is the inverse of  $g_{\alpha\gamma}$

$$g^{\alpha\gamma}g_{\alpha\nu} = \delta_{\nu}^{\gamma},$$

we finally find the expression of the affine connections in terms of the metric

$$\Gamma_{\beta\mu}^{\gamma} = \frac{1}{2}g^{\alpha\gamma}(g_{\alpha\beta,\mu} + g_{\alpha\mu,\beta} - g_{\beta\mu,\alpha}) \quad (5.26)$$

Are the  $\Gamma_{\beta\gamma}^{\alpha}$  components of a tensor?

They are not, and it is easy to see why. In a locally inertial frame the  $\Gamma_{\beta\gamma}^{\alpha}$  vanish, but in any other frame they don't. If it would be a tensor they should vanish in any frame.

In the first chapter we defined the Christoffel symbols as

$$\Gamma_{\mu\nu}^{\alpha} = \frac{\partial x^{\alpha}}{\partial \xi^{\lambda}} \frac{\partial^2 \xi^{\lambda}}{\partial x^{\mu} \partial x^{\nu}}. \quad (5.27)$$

This definition was a consequence of the equivalence principle. We did the following: We considered a free particle in a locally inertial frame  $\{\xi^{\alpha}\}$ :

$$\frac{d^2 \xi^{\alpha}}{d\tau^2} = 0. \quad (5.28)$$

Then we transformed this equation to an arbitrary coordinate system  $\{x^{\alpha}\}$  and we showed that it becomes

$$\frac{d^2 x^{\alpha}}{d\tau^2} + \Gamma_{\mu\nu}^{\alpha} \left[ \frac{dx^{\mu}}{d\tau} \frac{dx^{\nu}}{d\tau} \right] = 0, \quad (5.29)$$

with  $\Gamma_{\mu\nu}^{\alpha}$  defined in eq. (5.27).

In this chapter we have defined the  $\Gamma$ 's as those functions that satisfy the equation

$$\frac{\partial \vec{e}_{(\mu)}}{\partial x^{\nu}} = \Gamma_{\mu\nu}^{\alpha} \vec{e}_{(\alpha)}. \quad (5.30)$$

What is the relation between eq. (5.27) and eq. (5.30)?

In a locally inertial frame  $\{\xi^{\alpha}\}$  be  $\vec{e}_{M(\mu)}$  the constant basis vectors. If we make a coordinate transformation to a new coordinate system  $\{x^{\alpha'}\}$ , the new basis  $\{\vec{e}_{(\mu')}\}$  will be

$$\vec{e}_{(\mu')} = \Lambda^{\alpha}_{\mu'} \vec{e}_{M(\alpha)} = \frac{\partial \xi^{\alpha}}{\partial x^{\mu'}} \vec{e}_{M(\alpha)}. \quad (5.31)$$

In this frame, eq. (5.30) which defines the affine connections can be rewritten as

$$\frac{\partial}{\partial x^{\nu'}} \left[ \Lambda^{\beta}_{\mu'} \vec{e}_{M(\beta)} \right] = \Gamma_{\mu'\nu'}^{\alpha'} \Lambda^{\gamma}_{\alpha'} \vec{e}_{M(\gamma)} \quad (5.32)$$

or, being the  $\vec{e}_{M(\beta)}$  constant

$$\frac{\partial \Lambda^{\beta}_{\mu'}}{\partial x^{\nu'}} \vec{e}_{M(\beta)} = \Gamma_{\mu'\nu'}^{\alpha'} \Lambda^{\gamma}_{\alpha'} \vec{e}_{M(\gamma)}. \quad (5.33)$$

This equation can be re-written as

$$\left( \frac{\partial \Lambda^{\beta}_{\mu'}}{\partial x^{\nu'}} - \Gamma_{\mu'\nu'}^{\alpha'} \Lambda^{\beta}_{\alpha'} \right) \vec{e}_{M(\beta)} = 0. \quad (5.34)$$

We now multiply eq. (5.34) by  $\Lambda^{\sigma'}_{\beta}$  and find

$$\Lambda^{\sigma'}_{\beta} \frac{\partial \Lambda^{\beta}_{\mu'}}{\partial x^{\nu'}} - \Gamma^{\alpha'}_{\mu'\nu'} \Lambda^{\sigma'}_{\beta} \Lambda^{\beta}_{\alpha'} = 0. \quad (5.35)$$

Since  $\Lambda^{\sigma'}_{\beta} \Lambda^{\beta}_{\alpha'} = \delta^{\sigma'}_{\alpha'}$ , it follows that

$$\Gamma^{\sigma'}_{\mu'\nu'} = \Lambda^{\sigma'}_{\beta} \frac{\partial \Lambda^{\beta}_{\mu'}}{\partial x^{\nu'}} = \frac{\partial x^{\sigma'}}{\partial \xi^{\beta}} \frac{\partial^2 \xi^{\beta}}{\partial x^{\nu'} \partial x^{\mu'}},$$

which coincides with eq. (5.27). Thus, as expected, the two definitions are equivalent. How do the  $\Gamma^{\alpha}_{\beta\gamma}$  transform?

The easiest way to see it is from the definition (5.27). In an arbitrary coordinate system  $\{x^{\mu'}\}$  they are

$$\begin{aligned} \Gamma^{\lambda'}_{\mu'\nu'} &= \frac{\partial x^{\lambda'}}{\partial \xi^{\alpha}} \frac{\partial^2 \xi^{\alpha}}{\partial x^{\nu'} \partial x^{\mu'}} = \\ &= \frac{\partial x^{\lambda'}}{\partial x^{\rho}} \frac{\partial x^{\rho}}{\partial \xi^{\alpha}} \frac{\partial}{\partial x^{\mu'}} \left( \frac{\partial \xi^{\alpha}}{\partial x^{\sigma}} \frac{\partial x^{\sigma}}{\partial x^{\nu'}} \right) = \\ &= \frac{\partial x^{\lambda'}}{\partial x^{\rho}} \frac{\partial x^{\rho}}{\partial \xi^{\alpha}} \left[ \frac{\partial x^{\sigma}}{\partial x^{\nu'}} \frac{\partial^2 \xi^{\alpha}}{\partial x^{\tau} \partial x^{\sigma}} \frac{\partial x^{\tau}}{\partial x^{\mu'}} + \frac{\partial \xi^{\alpha}}{\partial x^{\sigma}} \frac{\partial^2 x^{\sigma}}{\partial x^{\nu'} \partial x^{\mu'}} \right] = \\ &= \frac{\partial x^{\lambda'}}{\partial x^{\rho}} \frac{\partial x^{\sigma}}{\partial x^{\nu'}} \frac{\partial x^{\tau}}{\partial x^{\mu'}} \Gamma^{\rho}_{\tau\sigma} + \frac{\partial x^{\lambda'}}{\partial x^{\sigma}} \frac{\partial^2 x^{\sigma}}{\partial x^{\nu'} \partial x^{\mu'}} \end{aligned} \quad (5.36)$$

The first term is what we should get if  $\Gamma^{\alpha}_{\beta\gamma}$  were a tensor. But we know it is not, and in fact there is an additional term.

## 5.6 Appendix C non coordinate basis

In Chapter 3 we have seen that if we pass from minkowskian coordinates  $\{x^{\alpha}\} \equiv (ct, x, y)$  to polar coordinates  $\{x^{\alpha'}\} \equiv (ct, r, \theta)$  the coordinate basis

$$\{\vec{e}_{(\alpha)}\} \rightarrow \begin{cases} \vec{e}_{(0)} & \rightarrow (1, 0, 0) \\ \vec{e}_{(1)} & \rightarrow (0, 1, 0) \\ \vec{e}_{(2)} & \rightarrow (0, 0, 1) \end{cases} \quad (5.37)$$

transforms to  $\{\vec{e}_{(\alpha')}\}$

$$\begin{cases} \vec{e}_{(0')} = \vec{e}_{(0)} \\ \vec{e}_{(1')} = \vec{e}_{(r)} = \cos \theta \vec{e}_{(1)} + \sin \theta \vec{e}_{(2)} \\ \vec{e}_{(2')} = \vec{e}_{(\theta)} = -r \sin \theta \vec{e}_{(1)} + r \cos \theta \vec{e}_{(2)} \end{cases} \quad (5.38)$$

according to the law

$$\vec{e}_{(\alpha')} = \Lambda^k_{\alpha'} \vec{e}_{(k)}.$$

The new basis is a coordinate basis and the matrix  $\Lambda^k_{\alpha'} = \frac{\partial x^k}{\partial x^{\alpha'}}$  is the matrix associated to the coordinate transformation. However we may choose a different basis for vectors. For example the vectors  $\{\vec{e}_{(\alpha')}\}$  in the previous example are not normalized. In fact

$$\vec{e}_{(\alpha')} \cdot \vec{e}_{(\beta')} = g_{\alpha'\beta'} = \begin{pmatrix} -1 & 0 & 0 \\ 0 & 1 & 0 \\ 0 & 0 & r^2 \end{pmatrix} \neq \eta_{\alpha'\beta'}.$$

We may decide that we want a basis composed by unit vectors, and choose

$$\begin{cases} \vec{e}_{\hat{r}} = \vec{e}_r \\ \vec{e}_{\hat{t}} = \vec{e}_t \\ \vec{e}_{\hat{\theta}} = \frac{1}{r}\vec{e}_\theta. \end{cases} \quad (5.39)$$

In this case we would find

$$\vec{e}_{(\hat{\alpha})} \cdot \vec{e}_{(\hat{\beta})} = \eta_{\hat{\alpha}\hat{\beta}}.$$

But now the question is: do there exist coordinates  $\{x^{\hat{\alpha}}\}$  such that

$$e_{(\hat{\alpha})} = \Lambda^i_{\hat{\alpha}} \vec{e}_{(i)} = \frac{\partial x^i}{\partial x^{\hat{\alpha}}} \vec{e}_{(i)}$$

so that the basis  $\{\vec{e}_{(\hat{\alpha})}\}$  is a coordinate basis? Alternatively, we can formulate the same question for the basis one-forms: if  $\{\omega^{(\alpha')}\}$  is the coordinate basis for one-forms and  $\{\omega^{(\hat{\alpha})}\}$  is the normalized basis, is  $\{\tilde{\omega}^{(\hat{\alpha})}\}$  a new coordinate basis associated to some coordinates  $\{x^{\hat{\alpha}}\}$ ? i.e.

$$\omega^{(\hat{\alpha})} = \Lambda^{\hat{\alpha}}_{\beta} \tilde{\omega}^{(\beta)} = \frac{\partial x^{\hat{\alpha}}}{\partial x^{\beta}} \tilde{\omega}^{(\beta)}?$$

(Show that in the previous example

$$\begin{aligned} \tilde{\omega}^{\hat{1}} &= \tilde{\omega}^r = \cos \theta \tilde{d}x + \sin \theta \tilde{d}y \\ \tilde{\omega}^{\hat{2}} &= \tilde{\omega}^\theta = r \tilde{d}\theta = -\sin \theta \tilde{d}x + \cos \theta \tilde{d}y \end{aligned} \quad (5.40)$$

The point is that if this is true,  $\Lambda^{\hat{\alpha}}_{\beta}$  **must coincide** with the partial derivative  $\frac{\partial x^{\hat{\alpha}}}{\partial x^{\beta}}$ , and consequently the following condition must be satisfied for any  $\Lambda^{\hat{\alpha}}_{\gamma}$ :

$$\frac{\partial}{\partial x^{\gamma}} \Lambda^{\hat{\alpha}}_{\beta} = \frac{\partial^2 x^{\hat{\alpha}}}{\partial x^{\gamma} \partial x^{\beta}} = \frac{\partial^2 x^{\hat{\alpha}}}{\partial x^{\beta} \partial x^{\gamma}} = \frac{\partial}{\partial x^{\beta}} \Lambda^{\hat{\alpha}}_{\gamma}. \quad (5.41)$$

This is an “integrability condition” that all the components of  $\Lambda^{\hat{\alpha}}_{\gamma}$  must satisfy in order the coordinates  $\{x^{\hat{\alpha}}\}$  do exist.

For examples, let us check whether the basis (5.40) is a coordinate basis. From the expression of  $\tilde{\omega}^{\theta}$  we find that

$$\Lambda^{\hat{2}}_1 = \frac{\partial x^{\hat{2}}}{\partial x} = -\sin \theta \quad \Lambda^{\hat{2}}_2 = \frac{\partial x^{\hat{2}}}{\partial y} = \cos \theta,$$

eq. (5.41) gives

$$\frac{\partial}{\partial y} \Lambda^{\hat{2}}_1 = \frac{\partial}{\partial x} \Lambda^{\hat{2}}_2 \Rightarrow \frac{\partial}{\partial y} (-\sin \theta) = \frac{\partial}{\partial x} (\cos \theta),$$

But

$$x = r \cos \theta \quad y = r \sin \theta \quad r = \sqrt{x^2 + y^2},$$

so that it should be

$$\frac{\partial}{\partial y} \left[ -\frac{y}{\sqrt{x^2 + y^2}} \right] = \frac{\partial}{\partial x} \left[ \frac{y}{\sqrt{x^2 + y^2}} \right],$$

which is certainly not true.

We conclude that the basis  $\{\tilde{\omega}^{(\hat{a})}\}$  **is not** a coordinate basis, since we cannot associate to it a coordinate transformation.

What are the consequences of choosing a noncoordinate basis?

As we have seen at the end of section 3.5, the gradient of a scalar field  $\Phi$  is a one-form:

$$\tilde{d}\Phi \rightarrow \left\{ \frac{\partial \Phi}{\partial x^\alpha} \right\} \equiv \{\Phi_{,\alpha}\} . \quad (5.42)$$

For example let us start in a 2-dimensional plane with coordinates  $(x, y) = (x^1, x^2)$ . Then change to polar coordinates  $(r, \theta) = (x^1, x^2)$ . The gradient will transform as one-forms do:

$$\tilde{d}\Phi_{j'} = \Lambda^k{}_{j'} \tilde{d}\Phi_k$$

where  $\tilde{d}\Phi_x = \Phi_{,x} = \frac{\partial \Phi}{\partial x}$  and  $\tilde{d}\Phi_y = \Phi_{,y} = \frac{\partial \Phi}{\partial y}$ .

The components of the gradient in the new coordinate basis are

$$\begin{cases} \tilde{d}\Phi_r = \Lambda^x{}_r \tilde{d}\Phi_x + \Lambda^y{}_r \tilde{d}\Phi_y = \frac{\partial x}{\partial r} \tilde{d}\Phi_x + \frac{\partial y}{\partial r} \tilde{d}\Phi_y \\ \tilde{d}\Phi_\theta = \Lambda^x{}_\theta \tilde{d}\Phi_x + \Lambda^y{}_\theta \tilde{d}\Phi_y = \frac{\partial x}{\partial \theta} \tilde{d}\Phi_x + \frac{\partial y}{\partial \theta} \tilde{d}\Phi_y. \end{cases} \quad (5.43)$$

Being

$$\begin{aligned} x &= r \cos \theta, \\ y &= r \sin \theta, \end{aligned}$$

$$\begin{cases} \tilde{d}\Phi_r = \cos \theta \tilde{d}\Phi_x + \sin \theta \tilde{d}\Phi_y = \frac{\partial \Phi}{\partial r} = \Phi_{,r} \\ \tilde{d}\Phi_\theta = -r \sin \theta \tilde{d}\Phi_x + r \cos \theta \tilde{d}\Phi_y = \frac{\partial \Phi}{\partial \theta} = \Phi_{,\theta}. \end{cases} \quad (5.44)$$

Thus the components of the gradient in the new coordinate basis  $(\vec{e}_{(r)}, \vec{e}_{(\theta)})$  will still be

$$\tilde{d}\Phi_{j'} \rightarrow \frac{\partial \Phi}{\partial x^{j'}} .$$

But this is certainly non true if we use the non coordinate basis  $\{\vec{e}_{(\hat{a})}\}$ : there are no-coordinates associated to this basis, thus we cannot define  $\tilde{d}\Phi_{\hat{j}} = \frac{\partial \Phi}{\partial x^{\hat{j}}}$  !

Let us see what happens to the affine connections if we use a non-coordinate basis. We have defined  $\Gamma_{\beta\gamma}^{\alpha}$  as

$$\nabla_{\alpha}\vec{e}_{(\beta)} = \frac{\partial\vec{e}_{(\beta)}}{\partial x^{\alpha}} = \Gamma_{\beta\alpha}^{\nu}\vec{e}_{(\nu)}. \quad (5.45)$$

This is a definition valid in any basis, therefore in terms of a noncoordinate basis  $\{\vec{e}_{(\hat{\alpha})}\}$  eq. (5.45) becomes

$$\nabla_{\hat{\alpha}}\vec{e}_{(\hat{\beta})} = \Gamma_{\hat{\beta}\hat{\alpha}}^{\hat{\nu}}\vec{e}_{(\hat{\nu})}. \quad (5.46)$$

But now, since the  $\{x^{\hat{\alpha}}\}$  do not exist, is not longer true that

$$\Phi_{,\hat{\beta};\hat{\alpha}} = \Phi_{,\hat{\alpha};\hat{\beta}}.$$

If we go back to eq.(5.23) we see that we used this condition to show the simmetry of the affine conection in the two lower indices. Thus if the basis is a non coordinate basis

$$\Gamma_{\hat{\beta}\hat{\gamma}}^{\hat{\alpha}} \neq \Gamma_{\hat{\gamma}\hat{\beta}}^{\hat{\alpha}}$$

and moreover eq (5.26) which gives the connections in terms of  $g_{\alpha\beta}$  is no longer true as well.

In the following of this course we shall use mainly coordinate basis, and we shall explicitly specify when we will use a non coordinate basis.

## 5.7 Summary of the preceding chapters

In the chapter I we have seen that the equation of motion of a particle which moves under the exclusive action of a gravitational field is

$$\frac{d^2x^{\alpha}}{d\tau^2} + \Gamma_{\mu\nu}^{\alpha} \left[ \frac{dx^{\mu}}{d\tau} \frac{dx^{\nu}}{d\tau} \right] = 0. \quad (5.47)$$

In this frame the line element is

$$ds^2 = g_{\mu\nu}dx^{\mu}dx^{\nu}. \quad (5.48)$$

Then we have seen that the Equivalence Principle allows to find a locally inertial frame  $\{\xi^{\alpha}\}$  where eq. (5.47) becomes

$$\frac{d^2\xi^{\alpha}}{d\tau^2} = 0, \quad (5.49)$$

and the line element reduces to

$$ds^2 = \eta_{\mu\nu}dx^{\mu}dx^{\nu}. \quad (5.50)$$

However we do not know if this transformation holds everywhere, i.e. if the spacetime is really flat, or if it holds only locally, which would mean that there is a non constant and non uniform gravitational field. It follows that the study of the motion of a single particle, or the knowledge of the  $\Gamma_{\mu\nu}^{\alpha}$  do not allow to decide whether we are in the presence of a gravitational field.

Then we have introduced vectors and tensors on a manifold, we have defined the metric tensor as a geometric object and we have shown that its role is not only that of defining the

distance between points, but also that of mapping vectors into one-forms, and of computing the scalar product between vectors. We have shown that if we introduce at each point of the manifold a basis for vectors  $\{\vec{e}_{(\alpha)}\}$  (and a dual basis for one forms  $\{\tilde{\omega}^{(\beta)}\}$ ) any vector (or one-form) can be assigned “components” with respect to the basis

$$\vec{A} = A^\alpha \vec{e}_{(\alpha)}. \quad (5.51)$$

Then we have introduced an operator of **covariant derivative**, which generates a tensor according to the following rule

$$\nabla_\beta V^\alpha = V^\alpha{}_{,\beta} + \Gamma^\alpha{}_{\mu\beta} V^\mu. \quad (5.52)$$

(and similar rules for tensors). The covariant derivative coincides with ordinary derivative in two particular cases:

1) the spacetime is flat **and** we are in a basis where the vectors  $\vec{e}_{(\alpha)}$  are constant. Consequently  $\Gamma^\alpha{}_{\mu\beta} = 0$ .

2) the spacetime is curved, but we are in a locally inertial frame. In fact, in this frame eq. (5.47) reduces to eq. (5.49), which means again that  $\Gamma^\alpha{}_{\mu\beta} = 0$ .

The fact that we can always find a frame where  $g_{\mu\nu}$  reduces to  $\eta_{\mu\nu}$  and the  $\Gamma^\alpha{}_{\mu\beta} = 0$  (and consequently the first derivatives of  $g_{\mu\nu}$  vanish) implies that in order to know if we are in the presence of a gravitational field, (i.e. if the spacetime is curved), **we need to know the second derivatives of the metric tensor**  $g_{\mu\nu,\alpha,\beta}$ . This result should not be surprising. In fact in chapter I when we introduced the 2-dimensional gaussian geometry we said that one can always choose a frame where the metric looks flat, but there exists a quantity, the gaussian curvature, which tells us if the space is flat or curved. The gaussian curvature is computed from product of first derivatives and from the second derivatives of the metric, thus we are now looking for a generalization of the gaussian curvature. We already mentioned that in four dimensions we need more than one invariant to describe the intrinsic properties of a curved surface: we need six functions, and it is clear that a vector would not be enough. Thus we need a tensor, but which tensor? At the moment we only know that it should contain the second derivatives of  $g_{\mu\nu}$ . But this is not enough. In order to introduce the curvature tensor we first need to introduce the notion of parallel transport of a vector along a curve.

## 5.8 Parallel Transport

In the chapter I we discussed and compared the intrinsic geometry of cones, cylinders and spheres, and we noticed that while it is flat for cones and cylinders, it is curved for spheres. That means, for example, that two lines which start parallel do not remain parallel when prolonged:

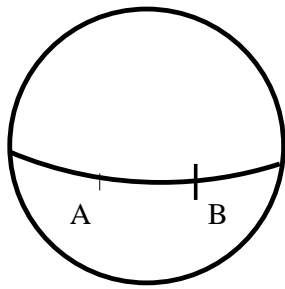

consider two segments in A and B, perpendicular to the equator, i.e. parallel.

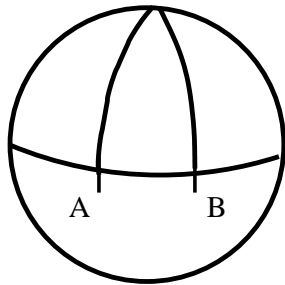

The same lines when prolonged: they do not remain parallel.

It is also interesting to see what happens when we parallelly transport a vector along a path. **Parallel Transport** means that for each infinitesimal displacement, the displaced vector must be parallel to the original one, and must have the same length. Let us consider first the case when the path belongs to a flat space.

a) *FLAT SPACE*

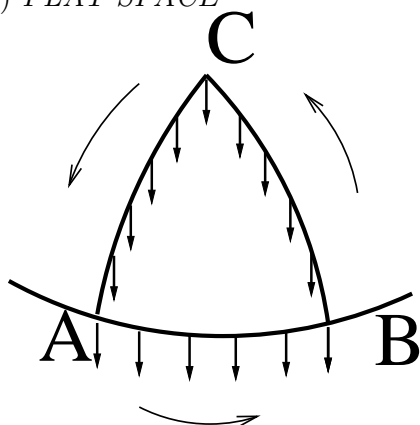

When we return to A the displaced vector coincides with the original vector in A.

b) *ON A SPHERE*

(remember that the vector must always be tangent to the sphere)

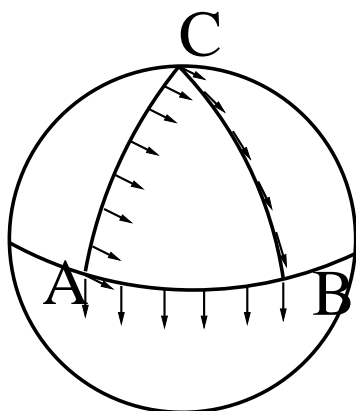

When the vector goes back to A it is rotated of 90 degrees. This is a consequence of the curvature of the sphere.

On a curved manifold it is impossible to define a globally parallel vector field. The parallel transport of a vector depends on the path along which it is transported.

Let us now compute how does a vector change when it is parallelly transported. Consider a curve of parameter  $\lambda$  and a vector field  $\vec{V}$  defined at every point of the curve. Be  $\vec{U} \rightarrow \left\{ \frac{dx^\alpha}{d\lambda} \right\}$  the vector tangent to the curve

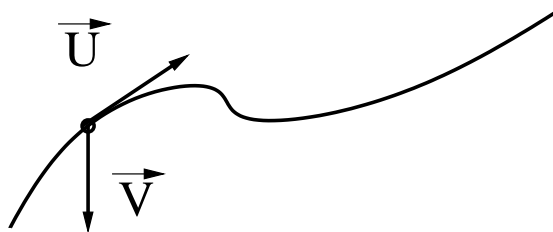

At every point of the curve we can choose a locally inertial frame  $\{\xi^\alpha\}$ . In this frame, if we move  $\vec{V}$  along the curve of an infinitesimal  $d\lambda$ , parallel to itself and keeping its length unchanged, its components do not change

$$\frac{dV^\alpha}{d\lambda} = 0. \quad (5.53)$$

But

$$\frac{dV^\alpha}{d\lambda} = \frac{dV^\alpha}{d\xi^\beta} \frac{d\xi^\beta}{d\lambda} = U^\beta V^\alpha{}_{,\beta} = 0. \quad (5.54)$$

Since we are in a locally inertial frame, ordinary and covariant derivative coincide and therefore we can write

$$U^\beta V^\alpha{}_{;\beta} = 0. \quad (5.55)$$

If this equation is true in a locally inertial frame, since it is a tensor equation it must be true in any other frame. Therefore eq. (5.55) is the frame-invariant definition of the **parallel transport** of  $\vec{V}$  along the curve identified by the tangent vector  $\vec{U}$ .

Eq. (5.55) is written in terms of the components of  $\vec{V}$  and  $\vec{U}$ ; if we want to write it in a frame-independent form we shall write

$$\frac{d\vec{V}}{d\lambda} = \nabla_{\vec{U}} \vec{V} = 0, \quad (5.56)$$

which means that the covariant derivative along the direction of the vector  $\vec{U}$  is zero. Written explicitly for a generic reference frame with coordinates  $\{x^\alpha\}$  eq. (5.56) gives

$$\begin{aligned} (\nabla_{\vec{U}} \vec{V})^\alpha &\equiv U^\beta V^\alpha{}_{;\beta} \\ &= \frac{dx^\beta}{d\lambda} \left[ \frac{\partial V^\alpha}{\partial x^\beta} + \Gamma^\alpha{}_{\beta\nu} V^\nu \right] = \frac{dV^\alpha}{d\lambda} + \Gamma^\alpha{}_{\beta\nu} V^\nu U^\beta = 0. \end{aligned} \quad (5.57)$$

Thus, contrary to what happens in flat space the components of a vector parallelly transported along a curve in curved space do change, and the change is given by

$$\frac{dV^\alpha}{d\lambda} = -\Gamma^\alpha{}_{\beta\nu} V^\nu U^\beta.$$

## 5.9 Geodesics are those curves which parallel-transport their own tangent vectors

Let us prove this statement. It says that geodesics are those curves such that

$$\nabla_{\vec{U}} \vec{U} = 0. \quad (5.58)$$

In components this becomes

$$U^\beta U^\alpha{}_{;\beta} = U^\beta [U^\alpha{}_{,\beta} + \Gamma^\alpha{}_{\mu\beta} U^\mu] = 0. \quad (5.59)$$

If  $\lambda$  is the parameter  $U^\beta = \frac{dx^\beta}{d\lambda}$ , and

$$U^\beta U^\alpha{}_{,\beta} = \left( \frac{\partial}{\partial x^\beta} \frac{dx^\alpha}{d\lambda} \right) \frac{dx^\beta}{d\lambda} = \frac{d^2 x^\alpha}{d\lambda^2}; \quad (5.60)$$

eq. (5.59) becomes

$$\frac{d^2 x^\alpha}{d\lambda^2} + \Gamma^\alpha{}_{\mu\beta} \left[ \frac{dx^\mu}{d\lambda} \frac{dx^\beta}{d\lambda} \right] = 0, \quad (5.61)$$

which is indeed the geodesic equation. The only difference is that in place of the proper time there is the parameter  $\lambda$ . However we can change the parameter (and make it coincides

with  $\tau$ ), which means that the path remains the same, but the curve changes. But there are some restrictions if we require the new curve to be a geodesic:

**If  $\lambda$  is a parameter of a geodesic, only linear transformations of  $\lambda$  :**

$$s = a\lambda + b, \quad a, b = \text{const}, \quad (5.62)$$

**give new parameters in which the geodesic equation is satisfied.**

In fact

$$\frac{d}{d\lambda} = \frac{d}{ds} \frac{ds}{d\lambda} = a \frac{d}{ds}, \quad (5.63)$$

and it is immediate to see that eq. (5.61) becomes

$$\frac{d^2 x^\alpha}{ds^2} + \Gamma_{\mu\nu}^\alpha \left[ \frac{dx^\mu}{ds} \frac{dx^\nu}{ds} \right] = 0. \quad (5.64)$$

$\lambda$  and  $s$  are called **affine parameters**.

# Chapter 6

## The Curvature Tensor

We are now in a position to introduce the curvature tensor. We will do it in two different ways.

### 6.1 a) A Formal Approach

Let us start writing the transformation rule for affine connections

$$\Gamma^\lambda_{\mu\nu} = \frac{\partial x^\lambda}{\partial x^{\tau'}} \frac{\partial x^{\rho'}}{\partial x^\mu} \frac{\partial x^{\sigma'}}{\partial x^\nu} \Gamma^{\tau'}_{\rho'\sigma'} + \frac{\partial x^\lambda}{\partial x^{\tau'}} \frac{\partial^2 x^{\tau'}}{\partial x^\mu \partial x^\nu}. \quad (6.1)$$

As we already noticed (Chapter V sec. 5) if the last term on the right-hand side would be zero  $\Gamma^\lambda_{\mu\nu}$  would transform as a tensor. Let us isolate the ‘bad term’, by multiplying eq. (6.1) by  $\frac{\partial x^{\tau'}}{\partial x^\lambda}$ :

$$\frac{\partial^2 x^{\tau'}}{\partial x^\mu \partial x^\nu} = \frac{\partial x^{\tau'}}{\partial x^\lambda} \Gamma^\lambda_{\mu\nu} - \frac{\partial x^{\rho'}}{\partial x^\mu} \frac{\partial x^{\sigma'}}{\partial x^\nu} \Gamma^{\tau'}_{\rho'\sigma'}. \quad (6.2)$$

We now differentiate this equation with respect to  $x^k$

$$\begin{aligned} \frac{\partial^3 x^{\tau'}}{\partial x^k \partial x^\mu \partial x^\nu} &= \frac{\partial^2 x^{\tau'}}{\partial x^k \partial x^\lambda} \Gamma^\lambda_{\mu\nu} + \frac{\partial x^{\tau'}}{\partial x^\lambda} \left( \frac{\partial}{\partial x^k} \Gamma^\lambda_{\mu\nu} \right) \\ &- \frac{\partial^2 x^{\rho'}}{\partial x^k \partial x^\mu} \frac{\partial x^{\sigma'}}{\partial x^\nu} \Gamma^{\tau'}_{\rho'\sigma'} - \frac{\partial x^{\rho'}}{\partial x^\mu} \frac{\partial^2 x^{\sigma'}}{\partial x^k \partial x^\nu} \Gamma^{\tau'}_{\rho'\sigma'} - \frac{\partial x^{\rho'}}{\partial x^\mu} \frac{\partial x^{\sigma'}}{\partial x^\nu} \left( \frac{\partial}{\partial x^k} \Gamma^{\tau'}_{\rho'\sigma'} \right). \end{aligned} \quad (6.3)$$

We now use eq. (6.2):

$$\begin{aligned} \frac{\partial^3 x^{\tau'}}{\partial x^k \partial x^\mu \partial x^\nu} &= \\ &+ \Gamma^\lambda_{\mu\nu} \left[ \frac{\partial x^{\tau'}}{\partial x^\alpha} \Gamma^\alpha_{k\lambda} - \frac{\partial x^{i'}}{\partial x^k} \frac{\partial x^{j'}}{\partial x^\lambda} \Gamma^{\tau'}_{i'j'} \right] + \frac{\partial x^{\tau'}}{\partial x^\lambda} \left[ \frac{\partial}{\partial x^k} \Gamma^\lambda_{\mu\nu} \right] \\ &- \frac{\partial x^{\sigma'}}{\partial x^\nu} \Gamma^{\tau'}_{\rho'\sigma'} \left[ \frac{\partial x^{\rho'}}{\partial x^\alpha} \Gamma^\alpha_{k\mu} - \frac{\partial x^{i'}}{\partial x^k} \frac{\partial x^{j'}}{\partial x^\mu} \Gamma^{\rho'}_{i'j'} \right] \end{aligned} \quad (6.4)$$

$$\begin{aligned}
& -\frac{\partial x^{\rho'}}{\partial x^{\mu}} \Gamma^{\tau'}{}_{\rho'\sigma'} \left[ \frac{\partial x^{\sigma'}}{\partial x^{\alpha}} \Gamma^{\alpha}{}_{k\nu} - \frac{\partial x^{i'}}{\partial x^k} \frac{\partial x^{j'}}{\partial x^{\nu}} \Gamma^{\sigma'}{}_{ij'} \right] \\
& -\frac{\partial x^{\rho'}}{\partial x^{\mu}} \frac{\partial x^{\sigma'}}{\partial x^{\nu}} \left( \frac{\partial}{\partial x^k} \Gamma^{\tau'}{}_{\rho'\sigma'} \right).
\end{aligned}$$

Let us rewrite the last term as

$$\frac{\partial x^{\rho'}}{\partial x^{\mu}} \frac{\partial x^{\sigma'}}{\partial x^{\nu}} \frac{\partial x^{\eta'}}{\partial x^k} \left( \frac{\partial}{\partial x^{\eta'}} \Gamma^{\tau'}{}_{\rho'\sigma'} \right). \quad (6.5)$$

(The reason is that the indices of  $\Gamma$  have a prime, thus the derivatives must be computed with respect to the  $\{x^{\alpha'}\}$ ). We now rewrite eq. (6.5) in the following way

$$\begin{aligned}
& \frac{\partial^3 x^{\tau'}}{\partial x^k \partial x^{\mu} \partial x^{\nu}} = \\
& \left[ \frac{\partial x^{\tau'}}{\partial x^{\lambda}} \left( \frac{\partial}{\partial x^k} \Gamma^{\lambda}{}_{\mu\nu} \right) + \left( \frac{\partial x^{\tau'}}{\partial x^{\alpha}} \Gamma^{\alpha}{}_{k\lambda} \Gamma^{\lambda}{}_{\mu\nu} \right) \right] \\
& - \left[ \frac{\partial x^{\rho'}}{\partial x^{\mu}} \frac{\partial x^{\sigma'}}{\partial x^{\nu}} \frac{\partial x^{\eta'}}{\partial x^k} \left( \frac{\partial}{\partial x^{\eta'}} \Gamma^{\tau'}{}_{\rho'\sigma'} \right) - \frac{\partial x^{\sigma'}}{\partial x^{\nu}} \frac{\partial x^{i'}}{\partial x^k} \frac{\partial x^{j'}}{\partial x^{\mu}} \Gamma^{\tau'}{}_{\rho'\sigma'} \Gamma^{\rho'}{}_{ij'} \right] \\
& - \left[ \frac{\partial x^{\rho'}}{\partial x^{\mu}} \frac{\partial x^{i'}}{\partial x^k} \frac{\partial x^{j'}}{\partial x^{\nu}} \Gamma^{\tau'}{}_{\rho'\sigma'} \Gamma^{\sigma'}{}_{ij'} \right] \\
& - \left[ \frac{\partial x^{\sigma'}}{\partial x^{\nu}} \Gamma^{\tau'}{}_{\rho'\sigma'} \frac{\partial x^{\rho'}}{\partial x^{\alpha}} \Gamma^{\alpha}{}_{k\mu} + \frac{\partial x^{\rho'}}{\partial x^{\mu}} \Gamma^{\tau'}{}_{\rho'\sigma'} \frac{\partial x^{\sigma'}}{\partial x^{\alpha}} \Gamma^{\alpha}{}_{k\nu} + \frac{\partial x^{i'}}{\partial x^k} \frac{\partial x^{j'}}{\partial x^{\lambda}} \Gamma^{\lambda}{}_{\mu\mu} \Gamma^{\tau'}{}_{ij'} \right].
\end{aligned} \quad (6.6)$$

We now relabel the indices in the following way

$$\frac{\partial x^{\tau'}}{\partial x^{\alpha}} \Gamma^{\alpha}{}_{k\lambda} \Gamma^{\lambda}{}_{\mu\nu} \rightarrow \frac{\partial x^{\tau'}}{\partial x^{\lambda}} \Gamma^{\lambda}{}_{k\eta} \Gamma^{\eta}{}_{\mu\nu} \quad (6.7)$$

$$\begin{aligned}
\frac{\partial x^{\sigma'}}{\partial x^{\nu}} \frac{\partial x^{i'}}{\partial x^k} \frac{\partial x^{j'}}{\partial x^{\mu}} \Gamma^{\tau'}{}_{\rho'\sigma'} \Gamma^{\rho'}{}_{ij'} & \rightarrow \frac{\partial x^{\sigma'}}{\partial x^{\nu}} \frac{\partial x^{\eta'}}{\partial x^k} \frac{\partial x^{\rho'}}{\partial x^{\mu}} \Gamma^{\tau'}{}_{\lambda\sigma'} \Gamma^{\lambda}{}_{\eta'\rho'} \\
\frac{\partial x^{\rho'}}{\partial x^{\mu}} \frac{\partial x^{i'}}{\partial x^k} \frac{\partial x^{j'}}{\partial x^{\nu}} \Gamma^{\tau'}{}_{\rho'\sigma'} \Gamma^{\sigma'}{}_{ij'} & \rightarrow \frac{\partial x^{\rho'}}{\partial x^{\mu}} \frac{\partial x^{\eta'}}{\partial x^k} \frac{\partial x^{\sigma'}}{\partial x^{\nu}} \Gamma^{\tau'}{}_{\rho'\lambda\sigma'} \Gamma^{\lambda}{}_{\eta'\sigma'}
\end{aligned}$$

$$\begin{aligned}
\frac{\partial x^{\sigma'}}{\partial x^{\nu}} \Gamma^{\tau'}{}_{\rho'\sigma'} \frac{\partial x^{\rho'}}{\partial x^{\alpha}} \Gamma^{\alpha}{}_{k\mu} & \rightarrow \frac{\partial x^{\rho'}}{\partial x^{\nu}} \Gamma^{\tau'}{}_{\sigma'\rho'} \frac{\partial x^{\sigma'}}{\partial x^{\lambda}} \Gamma^{\lambda}{}_{k\mu} \\
\frac{\partial x^{\rho'}}{\partial x^{\mu}} \Gamma^{\tau'}{}_{\rho'\sigma'} \frac{\partial x^{\sigma'}}{\partial x^{\alpha}} \Gamma^{\alpha}{}_{k\nu} & \rightarrow \frac{\partial x^{\rho'}}{\partial x^{\mu}} \Gamma^{\tau'}{}_{\rho'\sigma'} \frac{\partial x^{\sigma'}}{\partial x^{\lambda}} \Gamma^{\lambda}{}_{k\nu} \\
\frac{\partial x^{i'}}{\partial x^k} \frac{\partial x^{j'}}{\partial x^{\lambda}} \Gamma^{\lambda}{}_{\mu\mu} \Gamma^{\tau'}{}_{ij'} & \rightarrow \frac{\partial x^{\rho'}}{\partial x^k} \frac{\partial x^{\sigma'}}{\partial x^{\lambda}} \Gamma^{\lambda}{}_{\mu\mu} \Gamma^{\tau'}{}_{\rho'\sigma'}
\end{aligned}$$

With these changes the terms can be collected in the following way

$$\begin{aligned}
& \frac{\partial^3 x^{\tau'}}{\partial x^k \partial x^{\mu} \partial x^{\nu}} = \frac{\partial x^{\tau'}}{\partial x^{\lambda}} \left[ \left( \frac{\partial}{\partial x^k} \Gamma^{\lambda}{}_{\mu\nu} \right) + \Gamma^{\lambda}{}_{k\eta} \Gamma^{\eta}{}_{\mu\nu} \right] \\
& - \frac{\partial x^{\rho'}}{\partial x^{\mu}} \frac{\partial x^{\sigma'}}{\partial x^{\nu}} \frac{\partial x^{\eta'}}{\partial x^k} \left[ \left( \frac{\partial}{\partial x^{\eta'}} \Gamma^{\tau'}{}_{\rho'\sigma'} \right) - \Gamma^{\tau'}{}_{\lambda\sigma'} \Gamma^{\lambda}{}_{\eta'\rho'} - \Gamma^{\tau'}{}_{\rho'\lambda\sigma'} \Gamma^{\lambda}{}_{\eta'\sigma'} \right] \\
& - \frac{\partial x^{\sigma'}}{\partial x^{\lambda}} \Gamma^{\tau'}{}_{\rho'\sigma'} \left[ \Gamma^{\lambda}{}_{k\mu} \frac{\partial x^{\rho'}}{\partial x^{\nu}} + \Gamma^{\lambda}{}_{k\nu} \frac{\partial x^{\rho'}}{\partial x^{\mu}} + \Gamma^{\lambda}{}_{\mu\nu} \frac{\partial x^{\rho'}}{\partial x^k} \right].
\end{aligned} \quad (6.8)$$

We now subtract from this expression the same expression with  $k$  and  $\nu$  interchanged

$$\begin{aligned}
& \frac{\partial^3 x^{\tau'}}{\partial x^k \partial x^\mu \partial x^\nu} - \frac{\partial^3 x^{\tau'}}{\partial x^\nu \partial x^\mu \partial x^k} = 0 = \\
& \frac{\partial x^{\tau'}}{\partial x^\lambda} \left[ \left( \frac{\partial}{\partial x^k} \Gamma^\lambda_{\mu\nu} \right) + \Gamma^\lambda_{k\eta} \Gamma^\eta_{\mu\nu} \right] \\
& - \frac{\partial x^{\rho'}}{\partial x^\mu} \frac{\partial x^{\sigma'}}{\partial x^\nu} \frac{\partial x^{\eta'}}{\partial x^k} \left[ \left( \frac{\partial}{\partial x^{\eta'}} \Gamma^{\tau'}_{\rho'\sigma'} \right) - \Gamma^{\tau'}_{\lambda\sigma'} \Gamma^{\lambda'}_{\eta'\rho'} - \Gamma^{\tau'}_{\rho'\lambda} \Gamma^{\lambda'}_{\eta'\sigma'} \right] \\
& - \frac{\partial x^{\sigma'}}{\partial x^\lambda} \Gamma^{\tau'}_{\rho'\sigma'} \left[ \Gamma^\lambda_{k\mu} \frac{\partial x^{\rho'}}{\partial x^\nu} + \Gamma^\lambda_{k\nu} \frac{\partial x^{\rho'}}{\partial x^\mu} + \Gamma^\lambda_{\mu\nu} \frac{\partial x^{\rho'}}{\partial x^k} \right] - \\
& \frac{\partial x^{\tau'}}{\partial x^\lambda} \left[ \left( \frac{\partial}{\partial x^\nu} \Gamma^\lambda_{\mu k} \right) + \Gamma^\lambda_{\nu\eta} \Gamma^\eta_{\mu k} \right] \\
& + \frac{\partial x^{\rho'}}{\partial x^\mu} \frac{\partial x^{\sigma'}}{\partial x^k} \frac{\partial x^{\eta'}}{\partial x^\nu} \left[ \left( \frac{\partial}{\partial x^{\eta'}} \Gamma^{\tau'}_{\rho'\sigma'} \right) - \Gamma^{\tau'}_{\lambda\sigma'} \Gamma^{\lambda'}_{\eta'\rho'} - \Gamma^{\tau'}_{\rho'\lambda} \Gamma^{\lambda'}_{\eta'\sigma'} \right] \\
& + \frac{\partial x^{\sigma'}}{\partial x^\lambda} \Gamma^{\tau'}_{\rho'\sigma'} \left[ \Gamma^\lambda_{\nu\mu} \frac{\partial x^{\rho'}}{\partial x^k} + \Gamma^\lambda_{\nu k} \frac{\partial x^{\rho'}}{\partial x^\mu} + \Gamma^\lambda_{\mu k} \frac{\partial x^{\rho'}}{\partial x^\nu} \right]
\end{aligned} \tag{6.9}$$

collecting all terms we find

$$\begin{aligned}
& \frac{\partial x^{\tau'}}{\partial x^\lambda} \left[ \frac{\partial}{\partial x^k} \Gamma^\lambda_{\mu\nu} - \frac{\partial}{\partial x^\nu} \Gamma^\lambda_{\mu k} + \Gamma^\lambda_{k\eta} \Gamma^\eta_{\mu\nu} - \Gamma^\lambda_{\nu\eta} \Gamma^\eta_{\mu k} \right] \\
& - \frac{\partial x^{\rho'}}{\partial x^\mu} \frac{\partial x^{\sigma'}}{\partial x^\nu} \frac{\partial x^{\eta'}}{\partial x^k} \left[ \frac{\partial}{\partial x^{\eta'}} \Gamma^{\tau'}_{\rho'\sigma'} - \frac{\partial}{\partial x^{\sigma'}} \Gamma^{\tau'}_{\rho'\eta'} + \Gamma^{\tau'}_{\lambda\eta'} \Gamma^{\lambda'}_{\sigma'\rho'} - \Gamma^{\tau'}_{\lambda\sigma'} \Gamma^{\lambda'}_{\eta'\rho'} \right] = 0.
\end{aligned} \tag{6.10}$$

If we now define the following <sup>1</sup>

$$R^\lambda_{\mu\nu k} = - \left[ \frac{\partial}{\partial x^k} \Gamma^\lambda_{\mu\nu} - \frac{\partial}{\partial x^\nu} \Gamma^\lambda_{\mu k} + \Gamma^\lambda_{k\eta} \Gamma^\eta_{\mu\nu} - \Gamma^\lambda_{\nu\eta} \Gamma^\eta_{\mu k} \right], \tag{6.11}$$

we can write eq. (6.10) as the transformation law for the tensor

$$R^{\sigma'}_{\alpha'\beta'\gamma'} = \frac{\partial x^{\sigma'}}{\partial x^\lambda} \frac{\partial x^\mu}{\partial x^{\alpha'}} \frac{\partial x^\nu}{\partial x^{\beta'}} \frac{\partial x^k}{\partial x^{\gamma'}} R^\lambda_{\mu\nu k}. \tag{6.12}$$

The tensor (6.11) is **The Curvature Tensor**, also called **The Riemann Tensor**, and it can be shown that it is the only tensor that can be constructed by using the metric, its first and second derivatives, and which is linear in the second derivatives.

This way of defining the Riemann tensor is the “old-fashioned way”: it is based on the transformation properties of the affine connections. The idea underlying this derivation is that the information about the curvature of the space must be contained in the second derivative of the metric, and therefore in the first derivative of the  $\Gamma^\alpha_{\mu\nu}$ . But since we want to find a tensor out of them, we must eliminate in eq. (6.1) the part which does not transform as a tensor, and we do this in eq. (6.9).

---

<sup>1</sup>The - sign does not agree with the definition given in Weinberg, but it does agree with the definition given in many other textbooks. As we shall see in the next section it is irrelevant. What is important is to write the Einstein equations with the right signs!

## 6.2 b) The curvature tensor and the curvature of the spacetime

We shall now rederive the curvature tensor in a different way that explicitly shows why it expresses the curvature of a spacetime. This derivation, due to Levi Civita, will use the notion of parallel transport of a vector along a closed loop.

Consider a closed loop whose four sides are the coordinates lines  $x^1 = a$ ,  $x^1 = a + \delta a$ ,  $x^2 = b$ ,  $x^2 = b + \delta b$

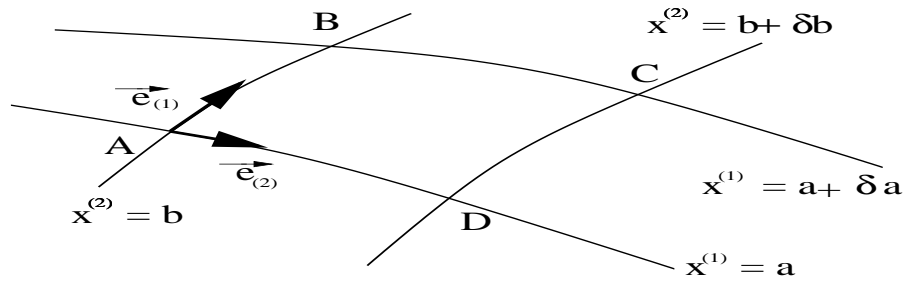

Take a generic vector  $\vec{V}$  and parallelly transport  $\vec{V}$  along AB, i.e. consider  $\nabla_{\vec{e}_{(1)}} \vec{V} = 0$ . From eq. (5.56) it follows that

$$e_{(1)}^\beta V^\alpha{}_{;\beta} = 0. \quad (6.13)$$

Since  $\vec{e}_{(1)}$  has only  $e_{(1)}^1 \neq 0$  then

$$\frac{\partial V^\alpha}{\partial x^1} + \Gamma^\alpha{}_{\mu 1} V^\mu = 0. \quad (6.14)$$

This equation can be integrated along the line AB:

$$\delta V_{AB}^\alpha = - \int_{A(x^2=b)}^B \Gamma^\alpha{}_{\mu 1} V^\mu dx^1. \quad (6.15)$$

In a similar way, if we go from B to C along the line  $x^1 = a + \delta a$

$$\frac{\partial V^\alpha}{\partial x^2} = -\Gamma^\alpha{}_{\mu 2} V^\mu \quad \rightarrow \quad \delta V_{BC}^\alpha = - \int_{B(x^1=a+\delta a)}^C \Gamma^\alpha{}_{\mu 2} V^\mu dx^2. \quad (6.16)$$

From C to D

$$\frac{\partial V^\alpha}{\partial x^1} = -\Gamma^\alpha{}_{\mu 1} V^\mu \quad \rightarrow \quad \delta V_{CD}^\alpha = - \int_{C(x^2=b+\delta b)}^D \Gamma^\alpha{}_{\mu 1} V^\mu dx^1, \quad (6.17)$$

and from D back to A

$$\frac{\partial V^\alpha}{\partial x^2} = -\Gamma^\alpha{}_{\mu 2} V^\mu \quad \rightarrow \quad \delta V_{DA}^\alpha = - \int_{D(x^1=a)}^A \Gamma^\alpha{}_{\mu 2} V^\mu dx^2. \quad (6.18)$$

The change in  $\vec{V}$  due to this parallel transport will be a vector  $\delta\vec{V}$  whose components can be found by adding eqs. (6.15)-(6.18):

$$\begin{aligned} \delta V^\alpha &= - \int_{D(x^1=a)}^A \Gamma^\alpha{}_{\mu 2} V^\mu dx^2 \\ &- \int_{B(x^1=a+\delta a)}^C \Gamma^\alpha{}_{\mu 2} V^\mu dx^2 - \int_{C(x^2=b+\delta b)}^D \Gamma^\alpha{}_{\mu 1} V^\mu dx^1 \\ &- \int_{A(x^2=b)}^B \Gamma^\alpha{}_{\mu 1} V^\mu dx^1. \end{aligned} \quad (6.19)$$

If the spacetime is flat  $V^\mu$  does not change when parallel transported, and  $\delta V^\alpha = 0$ . **But in curved spacetime  $\delta V^\alpha$  will in general be different from zero.**

If we consider an infinitesimal loop, i.e.  $\delta a$  and  $\delta b$  tend to zero, we can take an expansion of eq. (6.19) to first order in  $\delta a$  and  $\delta b$ :

$$\begin{aligned} \delta V^\alpha &\simeq - \int_{D(x^1=a)}^A \Gamma^\alpha{}_{\mu 2} V^\mu dx^2 - \\ &\left[ \int_{B(x^1=a)}^C \Gamma^\alpha{}_{\mu 2} V^\mu dx^2 + \frac{\partial}{\partial x^1} \left( \int_B^C \Gamma^\alpha{}_{\mu 2} V^\mu dx^2 \right) \delta a \right] \\ &- \left[ \int_{C(x^2=b)}^D \Gamma^\alpha{}_{\mu 1} V^\mu dx^1 + \frac{\partial}{\partial x^2} \left( \int_C^D \Gamma^\alpha{}_{\mu 1} V^\mu dx^1 \right) \delta b \right] \\ &- \int_{A(x^2=b)}^B \Gamma^\alpha{}_{\mu 1} V^\mu dx^1, \end{aligned} \quad (6.20)$$

Since

$$A = (a, b), \quad C = (a + \delta a, b + \delta b), \quad B = (a + \delta a, b), \quad \text{and} \quad D = (a, b + \delta b), \quad (6.21)$$

the previous equation becomes

$$\begin{aligned} \delta V^\alpha &\simeq + \int_b^{b+\delta b} \Gamma^\alpha{}_{\mu 2} V^\mu dx^2 \\ &- \int_b^{b+\delta b} \Gamma^\alpha{}_{\mu 2} V^\mu dx^2 - \left[ \int_b^{b+\delta b} \frac{\partial}{\partial x^1} (\Gamma^\alpha{}_{\mu 2} V^\mu) dx^2 \right] \delta a \\ &+ \int_a^{a+\delta a} \Gamma^\alpha{}_{\mu 1} V^\mu dx^1 + \left[ \int_a^{a+\delta a} \frac{\partial}{\partial x^2} (\Gamma^\alpha{}_{\mu 1} V^\mu) dx^1 \right] \delta b \\ &- \int_a^{a+\delta a} \Gamma^\alpha{}_{\mu 1} V^\mu dx^1, \end{aligned} \quad (6.22)$$

i.e.

$$\begin{aligned} \delta V^\alpha &\simeq -\delta a \int_b^{b+\delta b} \frac{\partial}{\partial x^1} (\Gamma^\alpha{}_{\mu 2} V^\mu) dx^2 \\ &+\delta b \int_a^{a+\delta a} \frac{\partial}{\partial x^2} (\Gamma^\alpha{}_{\mu 1} V^\mu) dx^1 \simeq \delta a \delta b \left[ -\frac{\partial}{\partial x^1} (\Gamma^\alpha{}_{\mu 2} V^\mu) + \frac{\partial}{\partial x^2} (\Gamma^\alpha{}_{\mu 1} V^\mu) \right]. \end{aligned} \quad (6.23)$$

Eq. (6.23) can be further developed by using eq. (6.14)

$$\frac{\partial V^\nu}{\partial x^1} = -\Gamma^\nu_{\mu 1} V^\mu, \quad \frac{\partial V^\nu}{\partial x^2} = -\Gamma^\nu_{\mu 2} V^\mu \quad (6.24)$$

and it becomes

$$\begin{aligned} \delta V^\alpha &= \delta a \delta b \left[ \frac{\partial \Gamma^\alpha_{\mu 1}}{\partial x^2} V^\mu + \Gamma^\alpha_{\nu 1} \frac{\partial V^\nu}{\partial x^2} - \frac{\partial \Gamma^\alpha_{\mu 2}}{\partial x^1} V^\mu - \Gamma^\alpha_{\nu 2} \frac{\partial V^\nu}{\partial x^1} \right] \\ &= \delta a \delta b \left[ \frac{\partial \Gamma^\alpha_{\mu 1}}{\partial x^2} - \frac{\partial \Gamma^\alpha_{\mu 2}}{\partial x^1} - \Gamma^\alpha_{\nu 1} \Gamma^\nu_{\mu 2} + \Gamma^\alpha_{\nu 2} \Gamma^\nu_{\mu 1} \right] V^\mu. \end{aligned} \quad (6.25)$$

What does that mean? The term in parenthesis is a number, thus eq. (6.25) says that the  $\delta V^\alpha$  are a linear combination of  $V^\mu$ . The indices 1 and 2 appear because we have chosen the path along  $x^1$  and  $x^2$  coordinates. **Note also that it is antisymmetric in 1 and 2** (if we interchange 1 and 2  $\delta V^\alpha$  reverse their sign, and this because we would go around the loop in opposite direction). If in place of  $x^1$  and  $x^2$ , we choose arbitrary coordinate lines  $x^\sigma$  and  $x^\lambda$  we find

$$\delta V^\alpha = \delta x^\sigma \delta x^\lambda \left[ \frac{\partial \Gamma^\alpha_{\mu \sigma}}{\partial x^\lambda} - \frac{\partial \Gamma^\alpha_{\mu \lambda}}{\partial x^\sigma} - \Gamma^\alpha_{\nu \sigma} \Gamma^\nu_{\mu \lambda} + \Gamma^\alpha_{\nu \lambda} \Gamma^\nu_{\mu \sigma} \right] V^\mu. \quad (6.26)$$

The term in parenthesis coincides with the definition of the Riemann tensor (6.11). If we would go around the loop in the opposite direction the sign would reverse. This shows that the sign can be chosen arbitrarily, and this is the reason why the definition of the Riemann tensor given in textbooks may differ for a sign. In the following we shall assume that the curvature tensor is

$$R^\alpha_{\beta \mu \nu} = \Gamma^\alpha_{\beta \nu, \mu} - \Gamma^\alpha_{\beta \mu, \nu} + \Gamma^\alpha_{\sigma \mu} \Gamma^\sigma_{\beta \nu} - \Gamma^\alpha_{\sigma \nu} \Gamma^\sigma_{\beta \mu}. \quad (6.27)$$

We have already shown that this is a tensor by looking at the way it transforms under a coordinate transformation (eq. 6.12). But we want to see if it also agrees with the definition of tensors given in chapter 4. Let us contract eq. (6.26) with  $V_\alpha$ .

$$\delta V^\alpha V_\alpha = \delta x^\sigma \delta x^\lambda \left[ \frac{\partial \Gamma^\alpha_{\mu \sigma}}{\partial x^\lambda} - \frac{\partial \Gamma^\alpha_{\mu \lambda}}{\partial x^\sigma} - \Gamma^\alpha_{\nu \sigma} \Gamma^\nu_{\mu \lambda} + \Gamma^\alpha_{\nu \lambda} \Gamma^\nu_{\mu \sigma} \right] V^\mu V_\alpha. \quad (6.28)$$

The result of this contraction is, of course, a number. First we note that (6.28) is linear in  $V^\alpha$ ,  $V_\alpha$ ,  $\delta a$ ,  $\delta b$ .  $\delta a$  and  $\delta b$  are the displacement along the basis vectors  $\vec{e}_{(\sigma)}$  and  $\vec{e}_{(\lambda)}$ , thus  $\delta V^\alpha$  depends linearly on  $\delta a \vec{e}_{(\sigma)}$  and  $\delta b \vec{e}_{(\lambda)}$ . If we consider a generic  $\begin{pmatrix} 1 \\ 3 \end{pmatrix}$  tensor,  $T^\alpha_{\beta \gamma \delta}$ , since by definition it is a linear function of one one-form and three vectors, when supplied with these arguments (for example the one-form  $\tilde{V}$ , and the three vectors  $\vec{V}, \delta a \vec{e}_{(\sigma)}, \delta b \vec{e}_{(\lambda)}$ ), it will produce the following number

$$T(\tilde{V}, \vec{V}, \delta a \vec{e}_{(\sigma)}, \delta b \vec{e}_{(\lambda)}) = T^\alpha_{\beta \rho \delta} V_\alpha V^\beta \delta a e^\sigma_{(\rho)} \delta b e^\lambda_{(\delta)}. \quad (6.29)$$

Eq. (6.29) has the same structure of eq. (6.28). Therefore we are entitled to define the components of the Riemann tensor as in eq. (6.27).

It should now be clear why the Riemann tensor deserves its name of **Curvature Tensor**: it tells us how does a vector change when it is parallelly transported along a loop, due to the curvature of the spacetime. If the spacetime is flat

$$\delta V^\alpha = 0 \quad \rightarrow \quad R^\alpha{}_{\beta\gamma\delta} = 0, \quad (6.30)$$

**in any reference frame.** The components of the Riemann tensor assume a very nice form when computed in a locally inertial frame:

$$R^\alpha{}_{\beta\mu\nu} = \frac{1}{2} g^{\alpha\sigma} [g_{\sigma\nu,\beta\mu} - g_{\sigma\mu,\beta\nu} + g_{\beta\mu,\sigma\nu} - g_{\beta\nu,\sigma\mu}], \quad (6.31)$$

or lowering the index  $\alpha$

$$R_{\alpha\beta\mu\nu} = g_{\alpha\lambda} R^\lambda{}_{\beta\mu\nu} = \frac{1}{2} [g_{\alpha\nu,\beta\mu} - g_{\alpha\mu,\beta\nu} + g_{\beta\mu,\alpha\nu} - g_{\beta\nu,\alpha\mu}]. \quad (6.32)$$

It should be stressed that

- 1) The Riemann tensor is linear in the second derivatives of  $g_{\mu\nu}$ .
- 2) In a locally inertial frame the  $\Gamma^\alpha{}_{\nu\sigma}$  vanish and therefore the non-linear part of the Riemann tensor vanishes as well.

### 6.3 Symmetries

From eq. (6.32) it is easy to verify that

$$R_{\alpha\beta\mu\nu} = -R_{\beta\alpha\mu\nu} = -R_{\alpha\beta\nu\mu} = R_{\mu\nu\alpha\beta}, \quad (6.33)$$

$$R_{\alpha\beta\mu\nu} + R_{\alpha\nu\beta\mu} + R_{\alpha\mu\nu\beta} = 0. \quad (6.34)$$

Since  $R_{\alpha\beta\mu\nu}$  is a tensor, these symmetry properties are valid in any reference frame. The symmetries of the Riemann tensor reduce the number of independent components to 20.

### 6.4 The Riemann tensor gives the commutator of covariant derivatives

Let us consider the second covariant derivatives of a vector field  $\vec{V}$

$$\nabla_\alpha \nabla_\beta V^\mu = \nabla_\alpha (V^\mu{}_{;\beta}) = (V^\mu{}_{;\beta})_{;\alpha} + \Gamma^\mu{}_{\sigma\alpha} V^\sigma{}_{;\beta} - \Gamma^\sigma{}_{\beta\alpha} V^\mu{}_{;\sigma}. \quad (6.35)$$

In a locally inertial frame  $\Gamma^\mu{}_{\sigma\alpha} = 0$ , and eq. (6.35) becomes

$$\nabla_\alpha \nabla_\beta V^\mu = (V^\mu{}_{;\beta})_{;\alpha} = V^\mu{}_{;\beta,\alpha} + \Gamma^\mu{}_{\nu\beta,\alpha} V^\nu. \quad (6.36)$$

By interchanging  $\alpha$  and  $\beta$

$$\nabla_\beta \nabla_\alpha V^\mu = (V^\mu{}_{;\alpha})_{;\beta} = V^\mu{}_{;\alpha,\beta} + \Gamma^\mu{}_{\nu\alpha,\beta} V^\nu. \quad (6.37)$$

The commutator of the covariant derivatives then is

$$[\nabla_\alpha, \nabla_\beta] V^\mu = \nabla_\alpha \nabla_\beta V^\mu - \nabla_\beta \nabla_\alpha V^\mu = (\Gamma^\mu_{\nu\beta, \alpha} - \Gamma^\mu_{\nu\alpha, \beta}) V^\nu. \quad (6.38)$$

Since in a locally inertial frame

$$R^\lambda_{\mu\nu k} = \Gamma^\lambda_{\mu k, \nu} - \Gamma^\lambda_{\nu k, \mu} \quad (6.39)$$

(equivalent to eq. 6.31), eq. (6.38) becomes

$$[\nabla_\alpha, \nabla_\beta] V^\mu = R^\mu_{\nu\alpha\beta} V^\nu. \quad (6.40)$$

This is a tensor equation and since it is valid in a given reference frame, it will be valid in **any** frame. Eq. (6.40) implies that in curved spacetime covariant derivatives **do not commute** and therefore the order in which they appear is important.

## 6.5 The Bianchi identities

Let us differentiate eq. (6.32) with respect to  $x^\lambda$  (and remember that it is valid in a locally inertial frame)

$$R_{\alpha\beta\mu\nu, \lambda} = \frac{1}{2} [g_{\alpha\nu, \beta\mu\lambda} - g_{\alpha\mu, \beta\nu\lambda} + g_{\beta\mu, \alpha\nu\lambda} - g_{\beta\nu, \alpha\mu\lambda}]. \quad (6.41)$$

By using the fact that  $g_{\alpha\beta}$  is symmetric and eq. (6.41) one can show that

$$R_{\alpha\beta\mu\nu, \lambda} + R_{\alpha\beta\lambda\mu, \nu} + R_{\alpha\beta\nu\lambda, \mu} = 0. \quad (6.42)$$

Since it is valid in a locally inertial frame and it is a tensor equation, it will be valid in any frame:

$$R_{\alpha\beta\mu\nu; \lambda} + R_{\alpha\beta\lambda\mu; \nu} + R_{\alpha\beta\nu\lambda; \mu} = 0, \quad (6.43)$$

where we have replaced the ordinary derivative with the covariant derivative. **These are the Bianchi identities that, as we shall see, play an important role in the development of the theory.**

# Chapter 7

## The stress-energy tensor

Now we know that there exists a tensor which allows to understand if the spacetime is curved or flat, i.e. if we are in the presence of a non-constant, non-uniform gravitational field. But in order to derive Einstein's equations, we still need to answer the following question: **how do we describe matter and fields in general relativity?** This question is relevant because we want to find what to put on the right-hand-side of the equations as a source of the gravitational field.

We shall first define the stress-energy tensor in a flat spacetime, and then generalize this notion to a generic spacetime.

In Special Relativity, we define the **energy-momentum** four-vector of a particle of mass  $m$  and velocity  $\mathbf{v} = \frac{d\mathbf{x}}{dt}$  in the following way

$$p^\alpha = mcu^\alpha, \quad \alpha = 0, 3, \quad (7.1)$$

where  $u^\alpha = \frac{d\xi^\alpha}{d\tau}$  is the four-velocity ( $u^\alpha u_\alpha = -1$ ),  $\tau$  is

$$d\tau^2 = -\eta_{\alpha\beta}d\xi^\alpha d\xi^\beta \quad \rightarrow \quad d\tau = (c^2 dt^2 - dx^2 - dy^2 - dz^2)^{1/2} = (1 - \frac{v^2}{c^2})^{1/2} c dt; \quad (7.2)$$

and

$$\eta_{\mu\nu} = \begin{pmatrix} -1 & 0 & 0 & 0 \\ 0 & 1 & 0 & 0 \\ 0 & 0 & 1 & 0 \\ 0 & 0 & 0 & 1 \end{pmatrix}. \quad (7.3)$$

Note that  $d\tau$  has the dimension of a length, and it is related to the particle proper time by the equation: **[proper time =  $\frac{1}{c}\tau$ ]**. In what follows, we shall indicate in boldface tri-vectors, for instance  $\mathbf{v}$ , whereas four-vectors will be indicated with an arrow, i.e.  $\vec{A}$ . Also remember that  $\{\xi^\alpha\}$  are the coordinates of a flat spacetime, or of a locally inertial frame.

The time-component of the energy-momentum vector does represent the energy of the particle

$$p^0 = \frac{E}{c}, \quad \gamma = (1 - v^2/c^2)^{-1/2}, \quad \text{and} \quad E = mc^2\gamma. \quad (7.4)$$

The space-components are the components of the three-dimensional momentum

$$\mathbf{p} = m\gamma\mathbf{v}. \quad (7.5)$$

What does it change if we are dealing with a continuous or discrete distribution of matter and energy? In that case we should be able to measure some other quantities, as the mass and the energy which are contained in a unitary volume, or the flux of energy and momentum that flows across the different faces of this volume. These informations are contained in the **stress-energy tensor** we are now going to define.

Let us consider the simple case of a system of  $n$  non-interacting particles located at some points  $\xi_n(t)$ , each with an energy-momentum vector  $p_n^\alpha$ .

We define the **density of energy** as

$$T^{00} \equiv \sum_n c p_n^0(t) \delta^3(\boldsymbol{\xi} - \boldsymbol{\xi}_n(t)) = \sum_n E_n \delta^3(\boldsymbol{\xi} - \boldsymbol{\xi}_n(t)), \quad (7.6)$$

the **density of momentum**  $\frac{1}{c} T^{0i}$ , where  $T^{0i}$  is defined as

$$T^{0i} \equiv \sum_n c p_n^i(t) \delta^3(\boldsymbol{\xi} - \boldsymbol{\xi}_n(t)), \quad i = 1, 3 \quad (7.7)$$

and the **current** of momentum as

$$T^{ki} \equiv \sum_n p_n^k(t) \frac{d\xi_n^i(t)}{dt} \delta^3(\boldsymbol{\xi} - \boldsymbol{\xi}_n(t)), \quad k = 1, 3 \quad i = 1, 3. \quad (7.8)$$

$\delta^3(\boldsymbol{\xi} - \boldsymbol{\xi}_n)$  is the Dirac delta-function defined by the statement that for any smooth function  $f(\boldsymbol{\xi})$

$$\int d^3\xi f(\boldsymbol{\xi}) \delta^3(\boldsymbol{\xi} - \boldsymbol{\xi}_n) = f(\boldsymbol{\xi}_n), \quad (7.9)$$

and if  $\boldsymbol{\xi}_n = (x_0, y_0, z_0)$

$$\delta^3(\boldsymbol{\xi} - \boldsymbol{\xi}_n) = \delta(x - x_0) \delta(y - y_0) \delta(z - z_0), \quad (7.10)$$

or, in polar coordinates

$$\delta^3(r - r_0) = \frac{1}{r^2 \sin^2 \theta} \delta(r - r_0) \delta(\theta - \theta_0) \delta(\varphi - \varphi_0). \quad (7.11)$$

Thus, according to the definition (7.9) the three-dimensional  $\delta$ -function has the dimensions of the inverse of a cubic length  $l^{-3}$ . For this reason, for example,  $T^{00}$  is, dimensionally, an energy ( $[cp^0]$ ) divided by a volume ( $[\delta^3]$ ) and therefore it is the energy density of the system<sup>1</sup> The definitions (7.6), (7.7) and (7.8) can be unified into a single formula

$$T^{\alpha\beta} = \sum_n p_n^\alpha \frac{d\xi_n^\beta(t)}{dt} \delta^3(\boldsymbol{\xi} - \boldsymbol{\xi}_n(t)), \quad \alpha, \beta = 0, 3, \quad (7.12)$$

---

<sup>1</sup>Properties of the  $\delta$ -function

$$\begin{aligned} \delta(x) &= \delta(-x), & \delta(cx) &= \frac{1}{|c|} \delta(x) \\ \delta[g(x)] &= \sum_j \frac{1}{|g'(x^j)|} \delta(x - x^j) & x\delta(x) &= 0 \\ \int dx f(x) \delta'(x - x_0) &= -f'(x_0). \end{aligned}$$

or, since

$$p_n^\alpha = \frac{E_n}{c^2} \frac{d\xi_n^\alpha(t)}{dt}, \quad (7.13)$$

eq. (7.12) can also be written as

$$T^{\alpha\beta} = c^2 \sum_n \frac{p_n^\alpha p_n^\beta}{E_n} \delta^3(\boldsymbol{\xi} - \boldsymbol{\xi}_n(t)), \quad (7.14)$$

which clearly shows that  $T^{\alpha\beta}$  is **symmetric**

$$T^{\alpha\beta} = T^{\beta\alpha}. \quad (7.15)$$

Finally, an alternative way of writing eq. (7.12) is

$$T^{\alpha\beta} = c \sum_n \int p_n^\alpha \frac{d\xi_n^\beta}{d\tau_n} \delta^4(\vec{\xi} - \vec{\xi}_n(\tau_n)) d\tau_n, \quad (7.16)$$

where

$$\delta^4(\vec{\xi} - \vec{\xi}_n) = \delta(\xi^0 - \xi_n^0) \delta(\xi^1 - \xi_n^1) \delta(\xi^2 - \xi_n^2) \delta(\xi^3 - \xi_n^3); \quad (7.17)$$

indeed, using the property (7.9) of the  $\delta$ -function it is easy to see that

$$\begin{aligned} T^{\alpha\beta} &= c \sum_n \int p_n^\alpha \frac{d\xi_n^\beta}{d\tau_n} \delta^4(\vec{\xi} - \vec{\xi}_n(\tau_n)) d\tau_n \\ &= c \sum_n \int \left[ p_n^\alpha \frac{d\xi_n^\beta}{d\tau_n} \delta^3(\boldsymbol{\xi} - \boldsymbol{\xi}_n(\tau_n)) \right] \delta(\xi^0 - \xi_n^0(\tau_n)) \frac{d\tau_n}{d\xi_n^0} d\xi_n^0 \\ &= c \sum_n \left[ p_n^\alpha \frac{d\xi_n^\beta}{d\xi_n^0} \delta^3(\boldsymbol{\xi} - \boldsymbol{\xi}_n(\tau_n)) \right]_{\xi^0(\tau_n)=\xi^0} \\ &= c \sum_n p_n^\alpha \frac{d\xi_n^\beta}{d\xi^0} \delta^3(\boldsymbol{\xi} - \boldsymbol{\xi}_n(\xi^0)) = \sum_n p_n^\alpha \frac{d\xi_n^\beta}{dt} \delta^3(\boldsymbol{\xi} - \boldsymbol{\xi}_n(\xi^0)) \end{aligned} \quad (7.18)$$

which coincides with (7.14)

Summarizing, the meaning of the different components is the following

$T^{00}$  = energy-density. In the non-relativistic case  $v \ll c$ ,  $p_n^0 \sim m_n c$  and  $T^{00} \sim \sum_n m_n c^2 \delta^3(\boldsymbol{\xi} - \boldsymbol{\xi}_n(t))$  reduces to the density of matter  $\rho c^2$  where

$$\rho = \sum_n m_n \delta^3(\boldsymbol{\xi} - \boldsymbol{\xi}_n(t)) \quad (7.19)$$

(remember the dimensions of the  $\delta$ -function) .

$\frac{1}{c} T^{0i}$  = density of momentum. Since the dimensions of the momentum  $\vec{p}$  are those of an energy divided by a velocity,  $[p^0] = [E/c]$ , it follows that  $c T^{0i}$  has the dimensions of  $[\frac{E}{tS}]$ , i.e. it is the energy which flows across the unit surface orthogonal to the axis  $\xi^i$  per unit time ( $i=1,3$ ) (see eq. (7.7)).

Similar dimensional considerations allow us to interpret  $T^{ik}$  as the flux of the  $i$ -th component of the three-momentum  $\mathbf{p}$  across the unit surface orthogonal to the axis  $\xi^k$

(i,k=1,3) (see eq. (7.8)).

Now we must check several things:

- 1) is  $T^{\alpha\beta}$  a tensor?
- 2) does it satisfy any conservation law? (remember that the energy-momentum four vector does satisfy a conservation law).

3) if it does, how to write this law in a curved spacetime, i.e. in the presence of a gravitational field?

1) **is  $T^{\alpha\beta}$  a tensor?**

Let us consider a **generic** coordinate transformation

$$\{\xi^\alpha\} \longrightarrow \{x^{\alpha'}\} \longrightarrow \xi^\alpha = \Lambda^\alpha_{\gamma'} x^{\gamma'}, \quad (7.20)$$

The four-momentum and the four-velocity transform as

$$p^\alpha = \Lambda^\alpha_{\gamma'} p^{\gamma'}, \quad u^\alpha \equiv \frac{d\xi^\alpha}{d\tau} = \Lambda^\alpha_{\gamma'} u^{\gamma'}. \quad (7.21)$$

In order to see how  $T^{\alpha\beta}$  transforms we need a brief digression to show how to transform  $\delta^4(x)$ .

In a four dimensional spacetime the volume element which is invariant under a generic coordinate transformation is  $\sqrt{-g} d^4x$ , i.e.

$$\sqrt{-g} d^4x = \sqrt{-g'} d^4x'. \quad (7.22)$$

Indeed,

$$d^4x = |J| d^4x', \quad (7.23)$$

where  $J = \det\left(\frac{\partial x^\alpha}{\partial x^{\beta'}}\right)$  is the Jacobian associated to the coordinate transformation. Since

$$g_{\alpha'\beta'} = \frac{\partial x^\mu}{\partial x^{\alpha'}} \frac{\partial x^\nu}{\partial x^{\beta'}} g_{\mu\nu}, \quad (7.24)$$

taking the determinant of both member we get

$$g' = J^2 g \quad \text{and therefore} \quad \sqrt{-g} = \frac{1}{|J|} \sqrt{-g'}. \quad (7.25)$$

Thus, if  $\{x^\alpha\} = \{\xi^\alpha\}$  is a Minkowskian frame, and  $\{x^{\alpha'}\}$  is a generic frame,

$$d^4\xi = \sqrt{-g} d^4x. \quad (7.26)$$

Let us now consider a delta-function in Minkowski's spacetime; its definition is

$$\int d^4\xi \delta^4(\vec{\xi} - \vec{\xi}_n) = 1, \quad (7.27)$$

and, in a generic frame,

$$\int d^4x \delta^4(\vec{x} - \vec{x}_n) = 1, \quad (7.28)$$

i.e.

$$\int \sqrt{-g} d^4x \frac{\delta^4(\vec{x} - \vec{x}_n)}{\sqrt{-g}} = \int \frac{\delta^4(\vec{x} - \vec{x}_n)}{\sqrt{-g}} d^4\xi = 1. \quad (7.29)$$

By comparing eq. (7.27) and eq. (7.29) we find the sought transformation formula for the delta-function

$$\delta^4(\vec{\xi} - \vec{\xi}_n) = \frac{\delta^4(\vec{x} - \vec{x}_n)}{\sqrt{-g}}. \quad (7.30)$$

Using eqs. (7.16), (7.21) and (7.30) it is now easy to find the transformation rule for  $T^{\alpha\beta}$ :

$$T^{\alpha\beta} = c \sum_n \int \Lambda^\alpha_{\gamma'} \Lambda^\beta_{\delta'} p_n^{\gamma'} \frac{dx_n^{\delta'}}{d\tau_n} \frac{\delta^4(\vec{x} - \vec{x}_n)}{\sqrt{-g}} d\tau_n. \quad (7.31)$$

Therefore if we define

$$T^{\alpha\beta} = c \sum_n \int \frac{1}{\sqrt{-g}} p_n^\alpha \frac{dx_n^\beta}{d\tau_n} \delta^4(\vec{x} - \vec{x}_n) d\tau_n, \quad (7.32)$$

under a generic coordinate transformation it will transform like

$$T^{\alpha\beta} = \Lambda^\alpha_{\gamma'} \Lambda^\beta_{\delta'} T^{\gamma'\delta'}. \quad (7.33)$$

and therefore it is a tensor. In flat spacetime, and in a locally inertial frame  $\sqrt{-g} = 1$  and we recover the definition (7.16). In conclusion, eq. (7.32) is the stress-energy tensor appropriate to describe a cloud of non interacting particles both in flat and in curved spacetime. Of course we may have different kind of matter and/or energy: a fluid, an electromagnetic field, etc. In that case it is possible to show that the corresponding stress-energy tensor can be derived by writing the action of the considered field, and by varying this action with respect to  $g_{\mu\nu}$ . However, the physical meaning of the different components of  $T^{\alpha\beta}$  will be the same.

We shall now use the tensor we have derived to answer the second important question we raised. The answer will be valid for the stress-energy tensor of any sort of matter-energy.

## 2) Does $T^{\alpha\beta}$ satisfy a conservation law?

Let us assume that we are in flat spacetime, and let us differentiate eq. (7.8):

$$\frac{\partial T^{\alpha i}}{\partial \xi^i} = \sum_n p_n^\alpha(t) \frac{d\xi_n^i(t)}{dt} \frac{\partial}{\partial \xi^i} \delta^3(\boldsymbol{\xi} - \boldsymbol{\xi}_n(t)), \quad (7.34)$$

where  $\alpha = 0, 3$  and  $i = 1, 2$ . Since

$$\frac{\partial}{\partial \xi^i} \delta^3(\boldsymbol{\xi} - \boldsymbol{\xi}_n(t)) = -\frac{\partial}{\partial \xi_n^i} \delta^3(\boldsymbol{\xi} - \boldsymbol{\xi}_n(t)), \quad (7.35)$$

eq. (7.34) becomes

$$\begin{aligned}
\frac{\partial T^{\alpha i}}{\partial \xi^i} &= - \sum_n p_n^\alpha(t) \frac{d\xi_n^i(t)}{dt} \frac{\partial}{\partial \xi_n^i} \delta^3(\boldsymbol{\xi} - \boldsymbol{\xi}_n(t)) \\
&= - \sum_n p_n^\alpha(t) \frac{d\xi_n^i(t)}{dt} \frac{\partial}{\partial t} \frac{\partial t}{\partial \xi_n^i} \delta^3(\boldsymbol{\xi} - \boldsymbol{\xi}_n(t)) \\
&= - \sum_n p_n^\alpha(t) \frac{\partial}{\partial t} \delta^3(\boldsymbol{\xi} - \boldsymbol{\xi}_n(t)).
\end{aligned} \tag{7.36}$$

By making use of eqs. (7.6) and (7.7), eq. (7.36) gives

$$\frac{\partial T^{\alpha i}}{\partial \xi^i} = -\frac{1}{c} \frac{\partial}{\partial t} T^{\alpha 0} + \sum_n \frac{dp_n^\alpha(t)}{dt} \delta^3(\boldsymbol{\xi} - \boldsymbol{\xi}_n(t)). \tag{7.37}$$

Since

$$\frac{dp_n^\alpha(t)}{dt} = \frac{dp_n^\alpha(\tau)}{d\tau} \frac{d\tau}{dt} = \frac{d\tau}{dt} f_n^\alpha, \tag{7.38}$$

where  $f_n^\alpha$  is the relativistic force, the last term in eq. (7.37) can be considered as a *density of force*  $G^\alpha$  defined as

$$G^\alpha(\boldsymbol{\xi}, t) = \sum_n \frac{dp_n^\alpha(t)}{dt} \delta^3(\boldsymbol{\xi} - \boldsymbol{\xi}_n(t)) = \sum_n \delta^3(\boldsymbol{\xi} - \boldsymbol{\xi}_n(t)) \frac{d\tau}{dt} f_n^\alpha. \tag{7.39}$$

It is a density because the  $\delta$ -function is [ $l^{-3}$ ]. If the particles are free,  $f_n^\alpha = 0$  and eq. (7.37) becomes

$$\frac{\partial}{\partial \xi^\beta} T^{i\beta} + \frac{1}{c} \frac{\partial}{\partial t} T^{0\beta} = \frac{\partial}{\partial \xi^\beta} T^{\alpha\beta} = 0, \tag{7.40}$$

or

$$T^{\alpha\beta}{}_{,\beta} = 0, \tag{7.41}$$

which is the conservation law we were looking for.

Why is  $T^{\alpha\beta}{}_{,\beta} = 0$  a conservation law? To answer this question, let us start with a familiar equation in classical electrodynamics. Consider, as an example, a collection of charged particles of density  $\rho$  enclosed in a volume  $V$ .

$$\frac{\partial}{\partial t} \int_V \rho dV \tag{7.42}$$

will be the variation of charge inside the volume  $V$ . Be  $S$  the surface enclosing the volume, and  $\mathbf{n}$  the normal vector, which is assumed to be positive if pointing outward.

$$\rho \mathbf{v} \cdot \mathbf{n} dS \tag{7.43}$$

will be the charge which flows across  $dS$  per unit time. It is positive if the charge goes out, negative if it flows in. Thus

$$\int_S \rho \mathbf{v} \cdot \mathbf{n} dS \tag{7.44}$$

is the total charge per unit time, which flows across the surface  $S$  enclosing the volume  $V$ . The continuity equation then says that

$$\frac{\partial}{\partial t} \int_V \rho dV = - \int_S \rho \mathbf{v} \cdot \mathbf{n} dS. \quad (7.45)$$

The minus sign is because the right-hand side is positive if the charge contained in  $V$  increases. If we now introduce the three-dimensional current

$$\mathbf{J} = \rho \mathbf{v}, \quad (7.46)$$

eq. (7.45) becomes

$$\frac{\partial}{\partial t} \int_V \rho dV = - \int_S \mathbf{J} \cdot \mathbf{n} dS. \quad (7.47)$$

We now apply the Gauss theorem:

$$\int_S \mathbf{J} \cdot \mathbf{n} dS = \int_V \text{div} \mathbf{J} dV, \quad (7.48)$$

and eq. (7.47) becomes

$$\frac{\partial}{\partial t} \int_V \rho dV = - \int_V \text{div} \mathbf{J} dV. \quad (7.49)$$

Since the volume  $V$  is arbitrary, we can write

$$\text{div} \mathbf{J} = - \frac{\partial \rho}{\partial t}, \quad (7.50)$$

or

$$\frac{\partial J_x}{\partial x} + \frac{\partial J_y}{\partial y} + \frac{\partial J_z}{\partial z} = - \frac{\partial \rho}{\partial t}, \quad (7.51)$$

which is the **continuity equation** in a differential form. Let us now transform eq. (7.50) in a four-dimensional form. We define a four-current

$$J^\alpha = \rho \frac{d\xi^\alpha}{dt} = (\rho c, \mathbf{J}), \quad (7.52)$$

Then eq. (7.50) becomes

$$\frac{\partial}{\partial \xi^\alpha} J^\alpha = 0, \quad \alpha = 0, 3. \quad (7.53)$$

We are now going to show that any current  $J^\alpha(x)$  which satisfies the conservation law (7.53) is associated to a total charge  $Q$  defined as

$$Q = \int_V J^0 dV, \quad (7.54)$$

which is conserved. **The integral in eq. (7.54) is evaluated at some fixed time, thus we say that the integration is performed on an hypersurface  $\xi^0 = \text{const}$  over the whole three-dimensional space.** The total charge  $Q$  is a conserved quantity for the following reason. By virtue of eq. (7.53)

$$\frac{1}{c} \frac{dQ}{dt} = \int_{\text{allspace}} \frac{1}{c} \frac{\partial}{\partial t} J^0 dV = - \int_{\text{allspace}} \text{div} \mathbf{J} dV = - \int_{\text{surface}} J^k dS_k. \quad (7.55)$$

The last equality follows from the application of the Gauss theorem, and the subscript ‘surface’ means that we are considering the flux of  $\mathbf{J}$  across the surface which encloses the whole space.  $dS_k$  are the element of surface orthogonal to  $\xi^k$ . If  $\mathbf{J}$  goes to zero at infinity, the last term in eq. (7.55) vanishes, and therefore the total charge  $Q$  is a conserved quantity.

And now let us go back to equation (7.41). Let us assume for example that  $\alpha = 0$ :

$$\frac{\partial T^{01}}{\partial \xi^1} + \frac{\partial T^{02}}{\partial \xi^2} + \frac{\partial T^{03}}{\partial \xi^3} = -\frac{\partial T^{00}}{\partial \xi^0}. \quad (7.56)$$

If we integrate over a volume  $V$  as we did before, we get

$$-\frac{\partial}{\partial \xi^0} \int_V T^{00} dV = \int_V \text{div}(T^{0k}) dV = \int_S T^{0k} dS_k. \quad (7.57)$$

Remembering that  $T^{00}$  is the energy-density and  $T^{0k}$  is the energy which flows across the unit surface orthogonal to  $\xi^k$  it is clear that eq. (7.57) expresses a law of conservation of energy, and a similar procedure can be used to find the conservation of momentum by putting  $\alpha = 1, 2, 3$ . In analogy with eq. (7.54) we can define a vector

$$P^\alpha = \int_V T^{\alpha 0} dV, \quad \alpha = 0, 3, \quad (7.58)$$

which can be identified as the conserved energy-momentum vector of the system. For example

$$P^0 = \int_V T^{00} dV, \quad (7.59)$$

does represent the total energy of the system. It is conserved because

$$\frac{1}{c} \frac{dP^0}{dt} = \frac{1}{c} \int_{\text{all space}} \frac{\partial}{\partial t} T^{00} dV = - \int_{\text{all space}} \frac{\partial}{\partial \xi^i} T^{0i} dV = - \int_{\text{surface}} T^{0i} dS_i = 0. \quad (7.60)$$

It should be reminded that this derivation has been carried out in the framework of Special Relativity.

### 3) How do we write this conservation law in curved spacetime?

In order to answer this question we need to state The Principle of General Covariance which will be the foundation of the theory of General Relativity:

## 7.1 The Principle of General Covariance

*A physical law is true if:*

1) *it is true in the absence of gravity, i.e. it reduces to the laws of special relativity when  $g_{\mu\nu} \rightarrow \eta_{\mu\nu}$  and  $\Gamma^\alpha_{\mu\nu}$  vanish.* It is clear that this first proposition includes the Equivalence Principle.

2) *In order to preserve their form under an arbitrary coordinate transformation, all equations must be generally covariant. This means that all equations must be expressed in a tensor form.*

The physical content of the Principle of General Covariance is that if a tensor equation is true in absence of gravity, then it is true in the presence of an *arbitrary* gravitational field. It should also be stressed that the Principle of General Covariance can be applied only on scales that are small compared with the typical distances associated to the gravitational field, (for example to the curvature) , because only on these scales one can construct locally inertial frames.

And now we can give an answer to the question 3). First we note that eq. (7.41) is valid in special relativity, i.e. in the absence of gravity, therefore, according to the Principle of Equivalence, it will hold in a locally inertial frame of a curved spacetime. In this frame, the covariant and ordinary derivative coincide, therefore we can write eq. (7.41) in the alternative form

$$T^{\alpha\beta}{}_{;\beta} = 0. \quad (7.61)$$

Then we observe that in the light of the Principle of General Covariance, since the conservation law (7.41) is a tensor equation, it will hold in any arbitrary frame. Thus in order to transform a generic tensor equation valid in Special Relativity to a *generally covariant* form it will suffice to replace the comma with a semi-colon. The general conservation law satisfied by the stress-energy tensor therefore is eq. (7.61).

### Is this a conservation law?

To answer this question we need to compute the covariant divergence of a tensor. From the expression of the affine connections in terms of the metric we find that

$$\Gamma^{\mu}{}_{\lambda\mu} = \frac{1}{2}g^{\mu m} \left( \frac{\partial g_{m\lambda}}{\partial x^{\mu}} + \frac{\partial g_{m\mu}}{\partial x^{\lambda}} - \frac{\partial g_{\lambda\mu}}{\partial x^m} \right). \quad (7.62)$$

The first and the third term give

$$g^{\mu m} \frac{\partial g_{m\lambda}}{\partial x^{\mu}} - g^{\mu m} \frac{\partial g_{\lambda\mu}}{\partial x^m} = g^{\mu m} \frac{\partial g_{m\lambda}}{\partial x^{\mu}} - g^{m\mu} \frac{\partial g_{\mu\lambda}}{\partial x^m} = 0, \quad (7.63)$$

due to the symmetry of  $g_{\alpha\beta}$ , therefore

$$\Gamma^{\mu}{}_{\lambda\mu} = \frac{1}{2}g^{\mu\rho} \frac{\partial g_{\rho\mu}}{\partial x^{\lambda}}. \quad (7.64)$$

For any arbitrary matrix  $M$

$$\text{Tr} \left[ M^{-1}(x) \frac{\partial}{\partial x^{\lambda}} M(x) \right] = \frac{\partial}{\partial x^{\lambda}} \ln[\text{Det}M(x)]. \quad (7.65)$$

But this is what we have on the right-hand side of eq. (7.64), therefore, if we call  $\text{Det}(g) = -g$ , eq. (7.64) becomes

$$\Gamma^{\mu}{}_{\lambda\mu} = \frac{1}{2} \frac{\partial}{\partial x^{\lambda}} \ln[-g] = \frac{1}{\sqrt{-g}} \frac{\partial}{\partial x^{\lambda}} \sqrt{-g}. \quad (7.66)$$

Thus for example, if  $V^{\mu}$  is a vector

$$V^{\lambda}{}_{;\lambda} = V^{\lambda}{}_{,\lambda} + \Gamma^{\lambda}{}_{\alpha\lambda} V^{\alpha} = \frac{1}{\sqrt{-g}} \frac{\partial}{\partial x^{\lambda}} (\sqrt{-g} V^{\lambda}), \quad (7.67)$$

and for  $T^{\mu\nu}$

$$T^{\mu\nu}{}_{;\mu} = \frac{1}{\sqrt{-g}} \frac{\partial}{\partial x^\mu} (\sqrt{-g} T^{\mu\nu}) + \Gamma^\nu{}_{\lambda\mu} T^{\mu\lambda}. \quad (7.68)$$

In particular, if  $F^{\mu\nu}$  is antisymmetric, the last term in eq. (7.68) is zero and

$$F^{\mu\nu}{}_{;\mu} = \frac{1}{\sqrt{-g}} \frac{\partial}{\partial x^\lambda} (\sqrt{-g} F^{\mu\nu}). \quad (7.69)$$

Now we go back to eq. (7.61). By using eq. (7.68) it becomes

$$\frac{\partial}{\partial x^\lambda} (\sqrt{-g} T^{\mu\nu}) = -\sqrt{-g} \Gamma^\nu{}_{\lambda\mu} T^{\mu\lambda}, \quad (7.70)$$

and this is not a conservation law. Thus we cannot define a conserved four-momentum as we did in Special Relativity. We may be tempted to define

$$P^\alpha = \int_V \sqrt{-g} T^{\alpha 0} dV, \quad \alpha = 0, 3, \quad (7.71)$$

but this would not be a vector. The physical reason for this failure is that now we are in General Relativity, and we must take into account not only the energy and momentum associated to matter, but also the energy which is carried by the gravitational field itself, and the momentum which may be carried by gravitational waves. However we shall see that if the spacetime admits some symmetry (for example if it is spherically or plane-symmetric, or it is invariant under time-translations etc.) conserved quantities can be defined.

# Chapter 8

## The Einstein equations

We now have all the elements needed to derive the equations of the gravitational field. We expect they will be more complicated than the linear equations of the electromagnetic field. For example electromagnetic waves are produced as a consequence of the motion of charged particles, but the energy and the momentum they carry **is not** a source for the electromagnetic field, and it does not appear on the right-hand side of the equations. In gravity the situation is different. The equation

$$E = mc^2, \tag{8.1}$$

establishes that mass and energy can transform one into another: they are different manifestation of the same physical quantity. It follows that if the mass is the source of the gravitational field, so must be the energy, and consequently both mass and energy should appear on the right-hand side of the field equations. This implies that the equations we are looking for will be non linear. For example a system of masses arbitrarily moving will radiate gravitational waves, which carry energy, which is in turn source of the gravitational field and must appear on the right-hand-side of the equations. However, since newtonian gravity works remarkably well when we are dealing with non relativistic particles, or in general when the gravitational field is weak, in formulating the new theory we shall require that in the weak field limit the new equations reduce to the Poisson equation

$$\nabla^2 \Phi = 4\pi G\rho, \tag{8.2}$$

where  $\rho$  is the matter density,  $\Phi$  is the newtonian potential and  $\nabla^2$  is the Laplace operator in cartesian coordinates

$$\nabla^2 = \frac{\partial^2}{\partial x^2} + \frac{\partial^2}{\partial y^2} + \frac{\partial^2}{\partial z^2}. \tag{8.3}$$

Let us start by asking how the equations should look in the weak field limit.

## 8.1 The geodesic equations in the weak field limit

Consider a non-relativistic particle which moves in a **weak and stationary** gravitational field. Be  $\tau$  the proper time. Since  $v \ll c$ , it follows that

$$\frac{dx^i}{dt} \ll c \quad \rightarrow \quad \frac{dx^i}{d\tau} \ll \frac{cdt}{d\tau} = \frac{dx^0}{d\tau}. \quad (8.4)$$

In an arbitrary coordinate system the geodesic equations are

$$\frac{d^2 x^\mu}{d\tau^2} + \Gamma_{\alpha\beta}^\mu \frac{dx^\alpha}{d\tau} \frac{dx^\beta}{d\tau} = 0 \quad \rightarrow \quad \frac{d^2 x^\mu}{d\tau^2} + \Gamma_{00}^\mu \left( \frac{cdt}{d\tau} \right)^2 = 0. \quad (8.5)$$

From the expressions of the affine connections in terms of  $g_{\mu\nu}$  we easily find that

$$\Gamma_{00}^\mu = \frac{1}{2} g^{\mu\sigma} (2g_{0\sigma,0} - g_{00,\sigma}). \quad (8.6)$$

In addition, if the field is stationary  $g_{0\sigma,0} = 0$ , and

$$\Gamma_{00}^\mu = -\frac{1}{2} g^{\mu\sigma} \frac{\partial g_{00}}{\partial x^\sigma}. \quad (8.7)$$

Since we have assumed that the gravitational field is weak, we can choose a coordinate system such that

$$g_{\mu\nu} = \eta_{\mu\nu} + h_{\mu\nu}, \quad |h_{\mu\nu}| \ll 1, \quad (8.8)$$

where  $h_{\mu\nu}$  is a small perturbation of the flat metric. In other words, we are assuming that the field is so weak that the metric is nearly flat. Since we are interested only in first order terms, we shall raise and lower indices with the flat metric  $\eta^{\mu\nu}$ . For example

$$h^\lambda{}_\nu = g^{\lambda\rho} h_{\rho\nu} \sim \eta^{\lambda\rho} h_{\rho\nu} + O(h_{\mu\nu}^2).$$

If we substitute eq. (8.8) into eq. (8.7), and retain only the terms up to first order in  $h_{\mu\nu}$  we find

$$\Gamma_{00}^\mu \sim -\frac{1}{2} \eta^{\mu\sigma} \frac{\partial h_{00}}{\partial x^\sigma}, \quad (8.9)$$

and the geodesic equation becomes

$$\frac{d^2 x^\mu}{d\tau^2} = \frac{1}{2} \eta^{\mu\alpha} \frac{\partial h_{00}}{\partial x^\alpha} \left( \frac{cdt}{d\tau} \right)^2, \quad (8.10)$$

or, splitting the time- and the space-components

$$\frac{d^2 \mathbf{x}}{d\tau^2} = \frac{1}{2} \nabla h_{00} \left( \frac{cdt}{d\tau} \right)^2, \quad \text{and} \quad \frac{d^2 ct}{d\tau^2} = -\frac{1}{2} \frac{\partial h_{00}}{\partial ct} \left( \frac{cdt}{d\tau} \right)^2 = 0, \quad (8.11)$$

where

$$\nabla \rightarrow \left( \frac{\partial}{\partial x}, \frac{\partial}{\partial y}, \frac{\partial}{\partial z} \right) \quad (8.12)$$

is the gradient in cartesian coordinates. The second equation vanishes because we have assumed that the field is stationary ( $\frac{\partial h_{00}}{\partial t} = 0$ ). We can rescale the time coordinate in such a way that  $\frac{cdt}{d\tau} = 1$  and the first of eqs. (8.11) becomes

$$\frac{d^2 \mathbf{x}}{d\tau^2} = \frac{1}{2} \nabla h_{00}. \quad (8.13)$$

We should remember that the corresponding newtonian equation is

$$\frac{d^2 \mathbf{x}}{dt^2} = -\nabla \Phi, \quad (8.14)$$

where  $\Phi$  is the gravitational potential given by the Poisson equation (8.2). By comparing eqs. (8.14) and (8.13), and since  $\tau = ct$  we see that it must be

$$h_{00} = -2\frac{\Phi}{c^2} + \text{const.} \quad (8.15)$$

For example if the field is stationary and spherically symmetric, the newtonian potential is

$$\Phi = -\frac{GM}{r}, \quad (8.16)$$

and if we require that  $h_{00}$  vanishes at infinity, the constant must be zero and eq. (8.15) gives

$$h_{00} = -2\frac{\Phi}{c^2}, \quad \text{and} \quad g_{00} = -(1 + 2\frac{\Phi}{c^2}). \quad (8.17)$$

**Thus we have shown that in the weak field limit the geodesic equations reduce to the newtonian law of gravitation.** This suggests the form that the field equations should have. In fact if the field is weak, matter will behave non-relativistically, i.e.  $T^{00} = T_{00} \sim \rho c^2$  and therefore the generalization of Laplace's equation (8.2) could be

$$\nabla^2 g_{00} = -\frac{8\pi G}{c^4} T_{00}. \quad (8.18)$$

But this equation is not even Lorentz-invariant! It doesn't work. However it suggests that if in place of a stationary field, we would have an arbitrary distribution of energy and matter, we should construct a tensor starting from  $g_{\mu\nu}$  and its derivatives such that the field equations are

$$G_{\mu\nu} = \frac{8\pi G}{c^4} T_{\mu\nu}, \quad (8.19)$$

where  $G_{\mu\nu}$  is an operator which acts on  $g_{\mu\nu}$  which we shall now define. It should be stressed that, by the Principle of General Covariance, if equation (8.19) holds in a given reference frame, it will hold in any other frame.

## 8.2 The Einstein's field equations

Let us first see which derivatives and of which order do we expect in  $G_{\mu\nu}$ . A comparison with the Laplace equation shows that  $G_{\mu\nu}$  must have the dimensions of a second derivative. In fact, suppose that it contains terms of this type

$$\frac{\partial^3 g_{\mu\nu}}{\partial x_\mu^3}, \quad \frac{\partial^2 g_{\mu\nu}}{\partial x_\mu^2} \cdot \frac{\partial g_{\mu\nu}}{\partial x_\nu}, \quad \frac{\partial g_{\mu\nu}}{\partial x_\nu}, \quad (8.20)$$

then, in order to be dimensionally homogeneous each term should be multiplied by a constant having the dimensions of a suitable power of a length

$$\frac{\partial^3 g_{\mu\nu}}{\partial x_\mu^3} \cdot l, \quad \frac{\partial^2 g_{\mu\nu}}{\partial x_\mu^2} \frac{\partial g_{\mu\nu}}{\partial x_\nu} \cdot l, \quad \frac{\partial g_{\mu\nu}}{\partial x_\nu} \cdot \frac{1}{l}. \quad (8.21)$$

In this case, a gravitational field acting on small or on very large scale would be described by equations where some of the terms would be negligible with respect to some others. This is unacceptable, because we want a set of equations that are valid at any scale, and consequently the only terms we can accept in  $G_{\mu\nu}$  are those containing the second derivatives of  $g_{\mu\nu}$  in a linear form and products of first derivatives. Let us summarize the assumptions that we need to make on  $G_{\mu\nu}$  :

- 1) it must be a tensor
- 2) it must be linear in the second derivatives, and it must contain products of first derivatives of  $g_{\mu\nu}$  .
- 3) Since  $T_{\mu\nu}$  is symmetric,  $G_{\mu\nu}$  also must be symmetric.
- 4) Since  $T_{\mu\nu}$  satisfies the "conservation law"  $T^{\mu\nu}{}_{;\mu} = 0$  ,  $G_{\mu\nu}$  must satisfy the same conservation law.

$$G^{\mu\nu}{}_{;\nu} = 0. \quad (8.22)$$

- 5) In the weak field limit it must reduce to (compare with eq. (8.18)

$$G_{00} \sim -\nabla^2 g_{00}. \quad (8.23)$$

In this last assumption the Principle of Equivalence and the weak field limit explicitly appear.

In the preceding section we have shown that there exists a tensor which is linear in the second derivatives of  $g_{\mu\nu}$  and non linear in the first derivatives. It is the Riemann tensor, given in eq. (6.31), and it contains the information on the gravitational field. However we cannot use it directly in the field equations we are looking for, since it has four indices (it is a  $\begin{pmatrix} 1 \\ 3 \end{pmatrix}$  tensor) while we need a  $\begin{pmatrix} 2 \\ 0 \end{pmatrix}$  (or  $\begin{pmatrix} 0 \\ 2 \end{pmatrix}$ ) tensor. In addition, the covariant divergence of the stress-energy tensor vanishes, and so must be also for the tensor we shall put on the left-hand side of eq. (8.19).

By contracting the Riemann tensor with the metric we can construct a  $\begin{pmatrix} 0 \\ 2 \end{pmatrix}$  tensor, i.e. **the Ricci tensor**:

$$R_{\mu\nu} = g^{k\alpha} R_{k\mu\alpha\nu} = R^\alpha{}_{\mu\alpha\nu}, \quad (8.24)$$

which is a symmetric tensor because of the symmetry property of the Riemann tensor

$$R_{k\mu\alpha\nu} = R_{\alpha\nu k\mu}, \quad (8.25)$$

and a scalar, called the **scalar curvature**

$$R = R^\alpha{}_\alpha. \quad (8.26)$$

The contraction in eq. (8.26) has the following meaning

$$R^\alpha{}_\alpha = R^0{}_0 + R^1{}_1 + R^2{}_2 + R^3{}_3. \quad (8.27)$$

It can be shown, by using the symmetries of the Riemann tensor, that  $R_{\mu\nu}$  and  $R$  are the only second rank tensor and scalar that can be constructed by contraction of  $R_{k\mu\alpha\nu}$  with the metric. Both in  $R_{\mu\nu}$  and  $R$  the second derivatives of  $g_{\mu\nu}$  appear linearly. Therefore the tensor we are looking for should have the following form

$$G_{\mu\nu} = C_1 R_{\mu\nu} + C_2 g_{\mu\nu} R, \quad (8.28)$$

where  $C_1$  and  $C_2$  are constants to be determined. The tensor  $G_{\mu\nu}$  satisfies the points 1,2 and 3. Condition 4 requires that

$$G^{\mu\nu}{}_{;\mu} = C_1 R^{\mu\nu}{}_{;\mu} + C_2 g^{\mu\nu} R_{;\mu} = 0. \quad (8.29)$$

(remember that the covariant derivative of  $g_{\mu\nu}$  vanishes). Now a very remarkable thing happens: eq. (8.29) is satisfied because of the Bianchi identities

$$R_{\lambda\mu\nu k;\eta} + R_{\lambda\mu\eta\nu;k} + R_{\lambda\mu k\eta;\nu} = 0. \quad (8.30)$$

In fact by contracting these equations we find

$$\begin{aligned} g^{\lambda\nu} (R_{\lambda\mu\nu k;\eta} + R_{\lambda\mu\eta\nu;k} + R_{\lambda\mu k\eta;\nu}) &= g^{\lambda\nu} (R_{\lambda\mu\nu k;\eta} - R_{\lambda\mu\nu\eta;k} + R_{\lambda\mu k\eta;\nu}) \\ &= (R_{\mu k;\eta} - R_{\mu\eta;k} + R^\nu{}_{\mu k\eta;\nu}) = 0. \end{aligned} \quad (8.31)$$

Contracting again

$$g^{\mu k} (R_{\mu k;\eta} - R_{\mu\eta;k} + R^\nu{}_{\mu k\eta;\nu}) = R_{;\eta} - R^k{}_{\eta;k} - R^\nu{}_{\eta;\nu} = 0. \quad (8.32)$$

The last expression can be rewritten in the following form

$$\left( R^{\mu\nu} - \frac{1}{2} g^{\mu\nu} R \right)_{;\nu} = 0. \quad (8.33)$$

Therefore, the Bianchi identities say that if

$$\frac{C_2}{C_1} = -\frac{1}{2}, \quad (8.34)$$

eq. (8.33) will be satisfied. We still need  $C_1$ .

In the weak field limit <sup>1</sup>

$$|T_{ij}| \ll |T_{00}|, \quad i, j = 1, 3, \quad (8.37)$$

and therefore

$$|G_{ij}| \ll |G_{00}|, \quad i, j = 1, 3. \quad (8.38)$$

From eqs. (8.28) and (8.34) it follows

$$|C_1 \left( R_{ij} - \frac{1}{2} g_{ij} R \right)| \ll |G_{00}|, \quad (8.39)$$

hence

$$R_{ij} \simeq \frac{1}{2} g_{ij} R. \quad (8.40)$$

Since  $g_{ij} \simeq \eta_{ij}$

$$R_{kk} \simeq \frac{1}{2} R, \quad k = 1, 3 \quad (8.41)$$

consequently

$$R = g^{\mu\nu} R_{\mu\nu} \simeq \eta^{\mu\nu} R_{\mu\nu} = -R_{00} + \sum_k R_{kk} = -R_{00} + \frac{3}{2} R, \quad (8.42)$$

and

$$R \simeq 2R_{00}. \quad (8.43)$$

Since

$$G_{\mu\nu} = C_1 \left( R_{\mu\nu} - \frac{1}{2} g_{\mu\nu} R \right), \quad (8.44)$$

we find

$$G_{00} \simeq C_1 2R_{00}. \quad (8.45)$$

If we now compute  $R_{00}$  in the weak field limit (assuming the field is stationary), we find that the non linear part is second order. Retaining only the first order terms we get

$$R_{00} \simeq -\frac{1}{2} \frac{\partial^2 g_{00}}{\partial x^i \partial x^j} = -\frac{1}{2} \nabla^2 g_{00}, \quad i, k = 1, 3 \quad (8.46)$$

namely

$$G_{00} \simeq -C_1 \nabla^2 g_{00}, \quad (8.47)$$

---

<sup>1</sup>The fact that in the weak field limit  $|T_{ik}| \ll T_{00}$  can be easily understood if we consider, as an example, a system on non-interacting particles. If  $\rho$  is the mass density

$$\rho = \sum_n m_n \delta^3(\mathbf{r} - \mathbf{r}_n), \quad (8.35)$$

where  $\mathbf{r}_n$  denotes the positions of the particles, the stress-energy tensor (7.14) can be also written as

$$T^{\mu\nu} = \rho c^2 \frac{dx^\mu}{d\tau} \frac{dx^\nu}{d\tau}. \quad (8.36)$$

It is clear that, if  $\frac{dx^i}{d\tau} \ll \frac{dx^0}{d\tau}$   $i = 1, 3$  the dominant term will be  $T^{00}$ .

A comparison of this equation with eq. (8.23) shows that if we require that the relativistic field equations reduce to the newtonian equations in the weak field limit it must be

$$C_1 = 1. \quad (8.48)$$

In conclusion, the Einstein's field equations are <sup>2</sup>

$$G_{\mu\nu} = \frac{8\pi G}{c^4} T_{\mu\nu}, \quad (8.49)$$

where

$$G_{\mu\nu} = \left( R_{\mu\nu} - \frac{1}{2} g_{\mu\nu} R \right), \quad (8.50)$$

and it is called **The Einstein tensor**. An alternative form is

$$R_{\mu\nu} = \frac{8\pi G}{c^4} \left( T_{\mu\nu} - \frac{1}{2} g_{\mu\nu} T \right). \quad (8.51)$$

In vacuum  $T_{\mu\nu} = 0$  and the Einstein equations reduce to

$$R_{\mu\nu} = 0. \quad (8.52)$$

Therefore, in vacuum the Ricci tensor vanishes, but the Riemann tensor does not, unless the gravitational field vanishes or is constant and uniform. We may still add to eqs. (8.49) the following term

$$\left( R_{\mu\nu} - \frac{1}{2} g_{\mu\nu} R - \lambda g_{\mu\nu} \right) = \frac{8\pi G}{c^4} T_{\mu\nu}. \quad (8.53)$$

where  $\lambda$  is a constant. This term satisfies the conditions 1,2,3 and 4, but not the condition 5. This means that it must be very small in such a way that in the weak field limit the equations reduce to the newtonian equations.

### 8.3 Gauge invariance of the Einstein equations

Since there are 10 independent components of  $G_{\mu\nu}$ , Einstein's equations provide 10 equations for the 10 independent components of  $g_{\mu\nu}$ . However these equations are not independent, because, as we have seen, the Bianchi identities imply the "conservation law"  $G^{\mu\nu}{}_{;\nu} = 0$ , which provides 4 relations that the Einstein tensor must satisfy. Thus the number of independent equations reduces to six.

Do we have six equations and 10 unknown functions? Why do we have these four degrees of freedom? The reason is the following. Be  $g_{\mu\nu}$  a solution of the equations. If we make a coordinate transformation  $x^{\mu'} = x^{\mu}(x^{\alpha})$  the 'transformed' tensor  $g'_{\mu\nu} = g_{\mu\nu'}$  is again

---

<sup>2</sup>Although we call these equations the Einstein equations, they were derived independently (and in a more elegant form) by D. Hilbert in the same year. However Einstein showed the implications of these equations in the theory of the solar system, and in particular that the precession of the perihelion of Mercury has a relativistic origin. This led to the theory's acceptance and since then the equations have been called the Einstein equations.

a solution, as established by the Principle of General Covariance. This also means that  $g_{\mu\nu}$  and  $g'_{\mu\nu}$  do represent the same physical solution (the same geometry) seen in different reference frames.

The coordinate transformation involves 4 arbitrary functions  $x'^{\mu}(x^{\alpha})$ , therefore the four degrees of freedom derive from the freedom of choosing the coordinate system, and disappear when we choose it. For example, we may choose a frame where four of the ten  $g_{\mu\nu}$  are zero.

Thus Einstein's equations do not determine the solution  $g_{\mu\nu}$  in a unique way, but only up to an arbitrary coordinate transformation. A similar situation arises in the case of Maxwell's equations in Special Relativity. In that case the equations for the vector potential<sup>3</sup>  $A^{\mu}$  are

$$\square A_{\alpha} - \frac{\partial^2 A^{\beta}}{\partial x^{\alpha} \partial x^{\beta}} = -\frac{4\pi}{c} J_{\alpha}. \quad (8.54)$$

(where  $\square = -\frac{\partial^2}{c^2 \partial t^2} + \nabla^2 = \eta^{\alpha\beta} \frac{\partial}{\partial x^{\alpha}} \frac{\partial}{\partial x^{\beta}}$ ). These are four equations for the four components of the vector potential. However they do not determine  $A^{\mu}$  uniquely, because of the conservation law

$$J^{\mu}{}_{,\mu} = 0, \quad \text{i.e.} \quad \frac{\partial}{\partial x^{\mu}} \left( \square A^{\mu} - \eta^{\mu\alpha} \frac{\partial^2 A^{\beta}}{\partial x^{\alpha} \partial x^{\beta}} \right) = 0. \quad (8.55)$$

Equation (8.55) plays the same role as the Bianchi identities do in our context. It provides **one** condition which must be satisfied by the components of  $A^{\mu}$ , therefore the number of independent Maxwell equations is three. The extra degree of freedom corresponds to a gauge invariance, which means the following.

If  $A_{\alpha}$  is a solution,

$$A'_{\alpha} = A_{\alpha} + \frac{\partial \Phi}{\partial x^{\alpha}}, \quad (8.56)$$

will also be a solution. In fact, by direct substitution we find

$$\square A'_{\alpha} - \frac{\partial}{\partial x^{\alpha}} \square \Phi - \frac{\partial^2 A'^{\beta}}{\partial x^{\alpha} \partial x^{\beta}} + \eta^{\beta\delta} \frac{\partial^2}{\partial x^{\alpha} \partial x^{\beta}} \frac{\partial \Phi}{\partial x^{\delta}} = -\frac{4\pi}{c} J_{\alpha}, \quad (8.57)$$

and since the second and the last term on the left hand-side cancel, it becomes

$$\square A'_{\alpha} - \eta^{\beta\delta} \frac{\partial^2 A'^{\delta}}{\partial x^{\alpha} \partial x^{\beta}} = -\frac{4\pi}{c} J_{\alpha}, \quad (8.58)$$

q.e.d.

Since  $\Phi$  is arbitrary, we can chose it in such a way that

$$\frac{\partial}{\partial x^{\beta}} A'^{\beta} = 0 \quad (8.59)$$

---

<sup>3</sup>Eq. (8.54) is the four-dimensional version of the wave equation for the vector potential

$$\square \mathbf{A} = \text{grad}(\text{div} \mathbf{A}) = -\frac{4\pi}{c} \mathbf{J}.$$

and eq. (8.58) becomes

$$\square A'_\alpha = -\frac{4\pi}{c} J_\alpha, \quad (8.60)$$

This is the Lorentz gauge.

Summarizing: in the electromagnetic case the extra degree of freedom on  $A_\mu$  is due to the fact that the vector potential is defined up to a function  $\Phi$  defined in eq. (8.56). In our case the **four** extra degrees of freedom are due to the fact that  $g_{\mu\nu}$  is defined up to a coordinate transformation. This gauge freedom is particularly useful when one is looking for exact solutions of Einstein's equations.

\*\*\*\*\*

## 8.4 Example: The armonic gauge.

\*\*\*\*\*

The armonic gauge is defined by the condition

$$\Gamma^\lambda = g^{\mu\nu}\Gamma_{\mu\nu}^\lambda = 0. \quad (8.61)$$

As we shall see in a next lecture, this gauge is of particular interest when we study the propagation of gravitational waves, because it simplifies the equations in a way similar to that of Maxwell's equations when written in the Lorentz gauge. It is always possible to choose this gauge indeed, given a generic coordinate transformation, the affine connections  $\Gamma_{\beta\gamma}^\alpha$  transform as (see eq. (6.1))

$$\Gamma_{\mu\nu}^{\lambda'} = \frac{\partial x^{\lambda'}}{\partial x^\rho} \frac{\partial x^\tau}{\partial x^\mu} \frac{\partial x^\sigma}{\partial x^{\nu'}} \Gamma_{\tau\sigma}^\rho - \frac{\partial x^\rho}{\partial x^{\nu'}} \frac{\partial x^\sigma}{\partial x^\mu} \frac{\partial^2 x^{\lambda'}}{\partial x^\rho \partial x^\sigma}. \quad (8.62)$$

When contracted with  $g^{\mu\nu'}$  this equation gives

$$\Gamma^{\lambda'} = \frac{\partial x^{\lambda'}}{\partial x^\rho} \Gamma^\rho - g^{\rho\sigma} \frac{\partial^2 x^{\lambda'}}{\partial x^\rho \partial x^\sigma}, \quad (8.63)$$

where we have made use of the relation

$$g^{\tau\sigma} = g^{\mu\nu'} \frac{\partial x^\tau}{\partial x^\mu} \frac{\partial x^\sigma}{\partial x^{\nu'}}. \quad (8.64)$$

Therefore, if  $\Gamma^\lambda$  is non zero, we can always find a frame where  $\Gamma^{\rho'} = 0$  and reduce to the armonic gauge. The condition  $\Gamma^\lambda = 0$  can be rewritten in a more elegant form remembering the expression of the affine connections in terms of the metric tensor

$$\Gamma^\lambda = \frac{1}{2} g^{\mu\nu} g^{\lambda k} \left\{ \frac{\partial g_{k\mu}}{\partial x^\nu} + \frac{\partial g_{k\nu}}{\partial x^\mu} - \frac{\partial g_{\mu\nu}}{\partial x^k} \right\} = 0. \quad (8.65)$$

Since

$$\begin{aligned} g^{\lambda k} \frac{\partial g_{k\mu}}{\partial x^\nu} &= -g_{k\mu} \frac{\partial g^{\lambda k}}{\partial x^\nu}, \\ \frac{1}{2} g^{\mu\nu} \frac{\partial g_{\mu\nu}}{\partial x^k} &= \sqrt{-g} \frac{\partial}{\partial x^k} \frac{1}{\sqrt{-g}}, \end{aligned} \quad (8.66)$$

it follows that

$$\Gamma^\lambda = \frac{1}{2} g^{\mu\nu} \left\{ -g_{k\mu} \left[ \frac{\partial g^{\lambda k}}{\partial x^\nu} \right] - g_{k\nu} \left[ \frac{\partial g^{\lambda k}}{\partial x^\mu} \right] \right\} - \frac{g^{\lambda k}}{\sqrt{-g}} \frac{\partial}{\partial x^k} \sqrt{-g} = 0. \quad (8.67)$$

The term in brackets is symmetric in  $\mu$  and  $\nu$ , therefore

$$\Gamma^\lambda = -\frac{1}{2} \left\{ 2g^{\mu\sigma} g_{k\mu} \frac{\partial g^{\lambda k}}{\partial x^\sigma} \right\} - \frac{g^{\lambda k}}{\sqrt{-g}} \frac{\partial}{\partial x^k} \sqrt{-g} = 0, \quad (8.68)$$

and, since  $g^{\mu\sigma} g_{k\mu} = \delta^\sigma_k$

$$\Gamma^\lambda = -\frac{\partial g^{\lambda k}}{\partial x^k} - \frac{g^{\lambda k}}{\sqrt{-g}} \frac{\partial}{\partial x^k} \sqrt{-g} = 0, \quad (8.69)$$

from which we find

$$-\frac{1}{\sqrt{-g}} \frac{\partial}{\partial x^k} (\sqrt{-g} g^{\lambda k}) = 0. \quad (8.70)$$

This means that

$$\Gamma^\lambda = 0 \quad \text{implies} \quad \frac{\partial}{\partial x^k} (\sqrt{-g} g^{\lambda k}) = 0. \quad (8.71)$$

The reason why this gauge is called ‘armonic’ is the following. A function  $\Phi$  is harmonic if

$$\square\Phi = 0, \quad (8.72)$$

where the operator  $\square$  is the **covariant d’Alambertian operator** defined as

$$\square\Phi = g^{\lambda k} \nabla_\lambda \nabla_k \Phi, \quad (8.73)$$

and  $\nabla_\lambda$  is the covariant derivative. Since

$$\begin{aligned} g^{\lambda k} \nabla_\lambda \nabla_k \Phi &= g^{\lambda k} \left( \frac{\partial \Phi_{;\lambda}}{\partial x^k} - \Gamma_{\lambda k}^\alpha \Phi_{;\alpha} \right) = \\ g^{\lambda k} \left[ \frac{\partial^2 \Phi}{\partial x^k \partial x^\lambda} - \Gamma_{\lambda k}^\alpha \frac{\partial \Phi}{\partial x^\alpha} \right] &= g^{\lambda k} \frac{\partial^2 \Phi}{\partial x^k \partial x^\lambda} - \Gamma^\alpha \frac{\partial \Phi}{\partial x^\alpha}. \end{aligned} \quad (8.74)$$

If  $\Gamma^\lambda = 0$  the harmonic gauge condition becomes

$$\square\Phi = g^{\lambda k} \frac{\partial^2 \Phi}{\partial x^k \partial x^\lambda} = 0. \quad (8.75)$$

If  $\Gamma^\lambda = 0$  then the **coordinates itself are harmonic functions**, in fact putting  $\Phi = x^\mu$  in eq. (8.75) one finds

$$\square x^\mu = g^{\lambda k} \frac{\partial^2 x^\mu}{\partial x^k \partial x^\lambda} = g^{\lambda k} \frac{\partial}{\partial x^k} \delta_\lambda^\mu = 0, \quad (8.76)$$

q.e.d. If the spacetime is flat, harmonic coordinates coincide with minkowskian coordinates.

# Chapter 9

## Symmetries

H. Weyl: “Symmetry, as wide or as narrow as you may define its meaning, is one idea by which man through the ages has tried to comprehend and create order, beauty, and perfection.”

The solution of a physical problem can be considerably simplified if it allows some symmetries. Consider for example the newtonian equations of gravity. It is easy to find a solution which is spherically symmetric, but it may be difficult to find the analytic solution for an arbitrary mass distribution.

In euclidean space a symmetry is related to an invariance with respect to some operation. For example plane symmetry implies invariance of the physical variables with respect to translations on a plane, spherically symmetric solutions are invariant with respect to translation on a sphere of constant radius, and the equations of newtonian gravity are symmetric with respect to time translations

$$t' \rightarrow t + \tau.$$

Thus a symmetry corresponds to invariance under translations along certain lines or over certain surfaces. This definition can be applied and extended to Riemannian geometry. We say that a solution of Einstein’s equations has a symmetry if there exists an  $n$ -dimensional manifold of points with  $1 \leq n \leq 4$ , such that the solution is invariant under translations which bring a point of this manifold into another point of the same manifold. For example, for spherically symmetric solutions the manifold is the 2-sphere, and  $n=2$ . This is a simple example, but we may have more complicated four-dimensional symmetries. These definitions can be made more precise by introducing the notion of Killing vectors.

### 9.1 The Killing vectors

Consider a vector field  $\vec{\xi}(x^\mu)$  defined at every point  $x^\alpha$  of a region of spacetime.  $\vec{\xi}$  identifies a symmetry if an infinitesimal translation along  $\vec{\xi}$  leaves the line-element unchanged, i.e.

$$\delta(ds^2) = \delta(g_{\alpha\beta}dx^\alpha dx^\beta) = 0. \quad (9.1)$$

This implies that

$$\delta g_{\alpha\beta} dx^\alpha dx^\beta + g_{\alpha\beta} [\delta(dx^\alpha) dx^\beta + dx^\alpha \delta(dx^\beta)] = 0. \quad (9.2)$$

$\vec{\xi}$  is the tangent vector to some curve  $x^\alpha(\lambda)$ , i.e.  $\xi^\alpha = \frac{dx^\alpha}{d\lambda}$ , therefore an infinitesimal translation in the direction of  $\vec{\xi}$  is an infinitesimal translation along the curve from a point  $P$  to the point  $P'$  whose coordinates are, respectively,

$$P = (x^\alpha) \quad \text{and} \quad P' = (x^\alpha + \delta x^\alpha).$$

Let us consider for example the 2-dimensional space indicated in the following figure

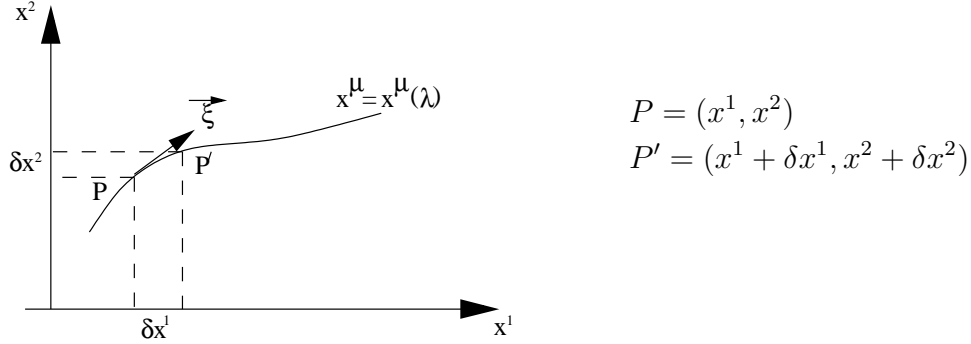

Since

$$\delta x^1 = \frac{dx^1}{d\lambda} d\lambda = \xi^1 d\lambda \quad \text{and} \quad \delta x^2 = \frac{dx^2}{d\lambda} d\lambda = \xi^2 d\lambda \quad (9.3)$$

the coordinates of the point  $P'$  in the general case are

$$x^{\alpha'} = x^\alpha + \xi^\alpha d\lambda. \quad (9.4)$$

When we move from  $P$  to  $P'$  the metric components change as follows

$$\begin{aligned} g_{\alpha\beta}(P') &\simeq g_{\alpha\beta}(P) + \frac{\partial g_{\alpha\beta}}{\partial \lambda} d\lambda + \dots \\ &= g_{\alpha\beta}(P) + \frac{\partial g_{\alpha\beta}}{\partial x^\mu} \frac{dx^\mu}{d\lambda} d\lambda + \dots \\ &= g_{\alpha\beta}(P) + g_{\alpha\beta,\mu} \xi^\mu d\lambda, \end{aligned} \quad (9.5)$$

hence

$$\delta g_{\alpha\beta} = g_{\alpha\beta,\mu} \xi^\mu d\lambda. \quad (9.6)$$

Moreover, since the operators  $\delta$  and  $d$  commute, we find

$$\begin{aligned} \delta(dx^\alpha) &= d(\delta x^\alpha) = d(\xi^\alpha d\lambda) = d\xi^\alpha d\lambda \\ &= \frac{\partial \xi^\alpha}{\partial x^\mu} dx^\mu d\lambda = \xi_{,\mu}^\alpha dx^\mu d\lambda. \end{aligned} \quad (9.7)$$

Thus, using eqs. (9.7) and (9.6), eq. (9.2) becomes

$$g_{\alpha\beta,\mu} \xi^\mu d\lambda dx^\alpha dx^\beta + g_{\alpha\beta} \left[ \xi_{,\mu}^\alpha dx^\mu d\lambda dx^\beta + \xi_{,\gamma}^\beta dx^\gamma d\lambda dx^\alpha \right] = 0, \quad (9.8)$$

and, after relabelling the indices,

$$\left[ g_{\alpha\beta,\mu} \xi^\mu + g_{\delta\beta} \xi_{,\alpha}^\delta + g_{\alpha\delta} \xi_{,\beta}^\delta \right] dx^\alpha dx^\beta d\lambda = 0. \quad (9.9)$$

In conclusion, a solution of Einstein's equations will be invariant under translations along  $\vec{\xi}$  if and only if

$$g_{\alpha\beta,\mu}\xi^\mu + g_{\delta\beta}\xi_{,\alpha}^\delta + g_{\alpha\delta}\xi_{,\beta}^\delta = 0. \quad (9.10)$$

In order to find the Killing vectors of a given a metric  $g_{\alpha\beta}$  we need to solve eq. (9.10), which is a system of differential equations for the components of  $\vec{\xi}(x^\mu)$ . If eq. (9.10) admits no solution, the spacetime has no symmetries. It may look like eq. (9.10) is not covariant, since it contains partial derivatives, but it is easy to show that it is equivalent to the following equation (see appendix A)

$$\xi_{\alpha;\beta} + \xi_{\beta;\alpha} = 0. \quad (9.11)$$

This is called the **Killing equation**.

### 9.1.1 Lie-derivative

The variation of a tensor under an infinitesimal translation along the direction of a vector field  $\vec{\xi}$  is called **Lie-derivative** ( $\vec{\xi}$  must not necessarily be a Killing vector), and it is indicated as  $L_{\vec{\xi}}$ . For a  $\begin{pmatrix} 0 \\ 2 \end{pmatrix}$  tensor

$$L_{\vec{\xi}}T_{\alpha\beta} = T_{\alpha\beta,\mu}\xi^\mu + T_{\delta\beta}\xi_{,\alpha}^\delta + T_{\alpha\delta}\xi_{,\beta}^\delta. \quad (9.12)$$

For the metric tensor

$$L_{\vec{\xi}}g_{\alpha\beta} = g_{\alpha\beta,\mu}\xi^\mu + g_{\delta\beta}\xi_{,\alpha}^\delta + g_{\alpha\delta}\xi_{,\beta}^\delta = \xi_{\alpha;\beta} + \xi_{\beta;\alpha}, \quad (9.13)$$

and if  $\vec{\xi}$  is a Killing vector the Lie-derivative of  $g_{\alpha\beta}$  must vanish.

### 9.1.2 Killing vectors coordinate systems

The existence of Killing vectors remarkably simplifies the problem of choosing a coordinate system appropriate to solve Einstein's equations. For example if we are looking for a solution which admits a timelike vector, we may choose the time axis aligned with this vector  $\vec{\xi}$  in such a way that the time coordinate lines coincide with the worldlines to which  $\vec{\xi}$  is tangent and consequently

$$\xi^\alpha = (\xi^0, 0, 0, 0). \quad (9.14)$$

If we parametrize the coordinate curves associated to  $\vec{\xi}$  in such a way that  $\xi^0$  is constant or equal unity, from eq. (9.10) it follows that

$$\frac{\partial g_{\alpha\beta}}{\partial x^0} = 0. \quad (9.15)$$

This means that **if the metric admits a timelike Killing vector, with an appropriate choice of the coordinate system it can be made independent of time.**

A similar procedure can be used if the metric admits a spacelike, or a null Killing vector. In

that case the metric would be independent of the space-coordinate, or of the null coordinate associated to the corresponding Killing vector. The map

$$f_t : M \rightarrow M$$

under which the metric is unchanged is called an *isometry*, and the Killing vector field is the generator of the isometry.

The family of worldlines to which the vector field  $\vec{\xi}$  is tangent, i.e. the **congruence of worldlines**, can be found by integrating the equations

$$\frac{dx^\mu}{d\lambda} = \xi^\mu(x^\alpha). \quad (9.16)$$

## 9.2 Examples

### 1) The Killing vectors of flat spacetime

The Killing vectors of Minkowski spacetime can be obtained very easily in cartesian coordinates. Since all Christoffel symbols vanish, the Killing equation becomes

$$\xi_{\alpha,\beta} + \xi_{\beta,\alpha} = 0. \quad (9.17)$$

If one combines the following equations

$$\xi_{\alpha,\beta\gamma} + \xi_{\beta,\alpha\gamma} = 0, \quad \xi_{\beta,\gamma\alpha} + \xi_{\gamma,\beta\alpha} = 0, \quad \xi_{\gamma,\alpha\beta} + \xi_{\alpha,\gamma\beta} = 0, \quad (9.18)$$

by using eq. (9.17) we find

$$\xi_{\alpha,\beta\gamma} = 0, \quad (9.19)$$

whose general solution is

$$\xi_\alpha = c_\alpha + \epsilon_{\alpha\gamma} x^\gamma \quad (9.20)$$

where  $c_\alpha$ ,  $\epsilon_{\alpha\beta}$  are general constants. Substitution into eq. (9.17) gives

$$\epsilon_{\alpha\gamma} x^\gamma_{,\beta} + \epsilon_{\beta\gamma} x^\gamma_{,\alpha} = \epsilon_{\alpha\gamma} \delta^\gamma_\beta + \epsilon_{\beta\gamma} \delta^\gamma_\alpha = \epsilon_{\alpha\beta} + \epsilon_{\beta\alpha} = 0$$

Therefore eq. (9.20) is the solution only if

$$\epsilon_{\alpha\beta} = -\epsilon_{\beta\alpha}. \quad (9.21)$$

The general Killing vector field of the form (9.20) can be written as the linear combination of ten Killing vector fields  $\xi_\alpha^{(A)} = \{\xi_\alpha^{(1)}, \xi_\alpha^{(2)}, \dots, \xi_\alpha^{(10)}\}$  corresponding to ten independent choices of the constants  $c_\alpha$ ,  $\epsilon_{\alpha\beta}$ :

$$\xi_\alpha^{(A)} = c_\alpha^{(A)} + \epsilon_{\alpha\gamma}^{(A)} x^\gamma \quad A = 1, \dots, 10. \quad (9.22)$$

For instance, we can choose

$$\begin{aligned} c_\alpha^{(1)} &= (1, 0, 0, 0) & \epsilon_{\alpha\beta}^{(1)} &= 0 \\ c_\alpha^{(2)} &= (0, 1, 0, 0) & \epsilon_{\alpha\beta}^{(2)} &= 0 \end{aligned}$$

$$\begin{aligned}
c_\alpha^{(3)} &= (0, 0, 1, 0) & \epsilon_{\alpha\beta}^{(3)} &= 0 \\
c_\alpha^{(4)} &= (0, 0, 0, 1) & \epsilon_{\alpha\beta}^{(4)} &= 0 \\
c_\alpha^{(5)} &= 0 & \epsilon_{\alpha\beta}^{(5)} &= \begin{pmatrix} 0 & 1 & 0 & 0 \\ -1 & 0 & 0 & 0 \\ 0 & 0 & 0 & 0 \\ 0 & 0 & 0 & 0 \end{pmatrix} \\
c_\alpha^{(6)} &= 0 & \epsilon_{\alpha\beta}^{(6)} &= \begin{pmatrix} 0 & 0 & 1 & 0 \\ 0 & 0 & 0 & 0 \\ -1 & 0 & 0 & 0 \\ 0 & 0 & 0 & 0 \end{pmatrix} \\
c_\alpha^{(7)} &= 0 & \epsilon_{\alpha\beta}^{(7)} &= \begin{pmatrix} 0 & 0 & 0 & 1 \\ 0 & 0 & 0 & 0 \\ 0 & 0 & 0 & 0 \\ -1 & 0 & 0 & 0 \end{pmatrix} \\
c_\alpha^{(8)} &= 0 & \epsilon_{\alpha\beta}^{(8)} &= \begin{pmatrix} 0 & 0 & 0 & 0 \\ 0 & 0 & 1 & 0 \\ 0 & -1 & 0 & 0 \\ 0 & 0 & 0 & 0 \end{pmatrix} \\
c_\alpha^{(9)} &= 0 & \epsilon_{\alpha\beta}^{(9)} &= \begin{pmatrix} 0 & 0 & 0 & 0 \\ 0 & 0 & 0 & 1 \\ 0 & 0 & 0 & 0 \\ 0 & -1 & 0 & 0 \end{pmatrix} \\
c_\alpha^{(10)} &= 0 & \epsilon_{\alpha\beta}^{(10)} &= \begin{pmatrix} 0 & 0 & 0 & 0 \\ 0 & 0 & 0 & 0 \\ 0 & 0 & 0 & 1 \\ 0 & 0 & -1 & 0 \end{pmatrix}
\end{aligned} \tag{9.23}$$

Therefore, there exist ten linearly independent Killing vectors in flat spacetime,

The symmetries generated by the Killing vectors with  $A = 1, \dots, 4$  are the spacetime translations; the symmetries generated by the Killing vectors with  $A = 5, 6, 7$  are the Lorentz boosts; the symmetries generated by the Killing vectors with  $A = 8, 9, 10$  are the space rotations.

2) *The Killing vectors of a spherical surface*

Consider a sphere of unit radius

$$ds^2 = d\theta^2 + \sin^2\theta d\varphi^2 = (dx^1)^2 + \sin^2 x^1 (dx^2)^2. \tag{9.24}$$

The Killing equation written in the form of eq. (9.10)

$$g_{\alpha\beta,\mu}\xi^\mu + g_{\delta\beta}\xi_{,\alpha}^\delta + g_{\alpha\delta}\xi_{,\beta}^\delta = 0$$

gives

$$\begin{aligned}
1) \quad \alpha = \beta = 1 & \quad 2g_{\delta 1}\xi_{,1}^\delta = 0 \rightarrow \xi_{,1}^1 = 0 \\
2) \quad \alpha = 1, \beta = 2 & \quad g_{\delta 2}\xi_{,1}^\delta + g_{1\delta}\xi_{,2}^\delta = 0 \rightarrow \xi_{,2}^1 + \sin^2\theta \xi_{,1}^2 = 0 \\
3) \quad \alpha = \beta = 2 & \quad g_{22,\mu}\xi^\mu + 2g_{\delta 2}\xi_{,2}^\delta = 0 \rightarrow \cos\theta \xi^1 + \sin\theta \xi_{,2}^2 = 0.
\end{aligned} \tag{9.25}$$

The general solution is

$$\xi^1 = A \sin(\varphi + a), \quad \xi^2 = A \cos(\varphi + a) \cot \theta + b. \quad (9.26)$$

Therefore a spherical surface admits three linearly independent Killing vectors depending on the choice of the integration constants  $(A, a, b)$ .

### 9.3 Conserved quantities in geodesic motion

Killing vectors are important because they are associated to conserved quantities, that may be hidden by an unsuitable choice of the coordinate system.

Let us consider a massive particle moving along a geodesic, and choose the affine parameter as being the proper time, so that the tangent vector is the four-velocity of the particle  $\vec{U} = \frac{dx^\alpha}{d\tau}$ . Geodesic equations can be written as follows

$$\frac{dU^\alpha}{d\tau} + \Gamma^\alpha_{\beta\nu} U^\beta U^\nu = 0. \quad (9.27)$$

Let us assume that the metric admits a Killing vector  $\vec{\xi}$ . If we contract eq. (9.27) with  $\vec{\xi}$  we find

$$\xi_\alpha \left[ \frac{dU^\alpha}{d\tau} + \Gamma^\alpha_{\beta\nu} U^\beta U^\nu \right] = \frac{d(\xi_\alpha U^\alpha)}{d\tau} - U^\alpha \frac{d\xi_\alpha}{d\tau} + \Gamma^\alpha_{\beta\nu} U^\beta U^\nu \xi_\alpha. \quad (9.28)$$

Since

$$U^\alpha \frac{d\xi_\alpha}{d\tau} = U^\beta \frac{d\xi_\beta}{d\tau} = U^\beta \frac{\partial \xi_\beta}{\partial x^\nu} \frac{dx^\nu}{d\tau} = U^\beta U^\nu \frac{\partial \xi_\beta}{\partial x^\nu}, \quad (9.29)$$

and eq. (9.28) becomes

$$\frac{d(\xi_\alpha U^\alpha)}{d\tau} - U^\beta U^\nu \left[ \frac{d\xi_\beta}{dx^\nu} - \Gamma^\alpha_{\beta\nu} \xi_\alpha \right] = 0, \quad (9.30)$$

or

$$\frac{d(\xi_\alpha U^\alpha)}{d\tau} - U^\beta U^\nu \xi_{\beta;\nu} = 0. \quad (9.31)$$

Since  $\xi_{\beta;\nu}$  is antisymmetric in  $\beta$  and  $\nu$ , when contracted on  $U^\beta U^\nu$  which is symmetric, gives zero as a result. Finally eq. (9.31) becomes

$$\frac{d(\xi_\alpha U^\alpha)}{d\tau} = 0. \quad (9.32)$$

This means that the quantity

$$\xi_\alpha U^\alpha = \text{const}, \quad (9.33)$$

is a constant of motion for the particle. Thus in mechanics for every Killing vector there is an associated conserved quantity. If  $\vec{\xi}$  is a timelike Killing vector eq. (9.33) expresses the conservation of the particle energy, if  $\vec{\xi}$  is spacelike it expresses momentum conservation.

It should be reminded that if the particle is massless, its geodesic equation cannot be parametrized with the proper time because  $d\tau = \frac{1}{c} \sqrt{-ds^2} = 0$ . In this case one has to use

an affine parameter  $\lambda$  using which the geodesic equation has the same form as eq. (9.27). In this case the particle four-velocity will be  $U^\alpha = \frac{dx^\alpha}{d\lambda}$  and the derivation of the constant of motion in presence of symmetries is the same as for massive particles.

It should be mentioned that in Riemannian spaces there may exist conservation laws which cannot be traced back to the presence of a symmetry, and therefore to the existence of a Killing vector field.

## 9.4 Killing vectors and conservation laws

In Chapter 7 we have shown that the stress-energy tensor satisfies the “conservation law”

$$T^{\mu\nu}{}_{;\nu} = 0, \quad (9.34)$$

and we have shown that in general this is not a genuine conservation law. If the spacetime admits a Killing vector, then

$$(\xi_\mu T^{\mu\nu})_{;\nu} = \xi_{\mu;\nu} T^{\mu\nu} + \xi_\mu T^{\mu\nu}{}_{;\nu} = 0. \quad (9.35)$$

In fact the second term vanishes because of eq. (9.34) and the first vanishes because  $\xi_{\mu;\nu}$  is antisymmetric, and  $T^{\mu\nu}$  is symmetric. But now the quantity  $(\xi_\mu T^{\mu\nu})$  is a vector, and according to eq. (7.67)

$$V^\nu{}_{;\nu} = \frac{1}{\sqrt{-g}} \frac{\partial}{\partial x^\nu} (\sqrt{-g} V^\nu), \quad (9.36)$$

therefore eq. (9.35) is equivalent to

$$\frac{1}{\sqrt{-g}} \frac{\partial}{\partial x^\nu} [\sqrt{-g} (\xi_\mu T^{\mu\nu})] = 0, \quad (9.37)$$

and accordingly, a conserved quantity can be defined as

$$T = \int_{(x^0=const)} \sqrt{-g} (\xi_\mu T^{\mu 0}) dx^1 dx^2 dx^3, \quad (9.38)$$

as we showed in Chapter 7. If the Killing vector is timelike, the associated conserved quantity will be called energy. (Remember that in classical mechanics energy is conserved when the hamiltonian is time independent, thus conservation of energy is associated to a symmetry with respect to translations in time, which is precisely what the existence of a timelike Killing vector means, except that now ‘time’ means the  $x^0$ -coordinate). Thus the energy of a gravitational system can be defined in a non ambiguous way only if there exists a timelike Killing vector field. Similarly when there is a spacelike Killing vector the associated conserved quantities are called momentum or angular momentum, though this is more a matter of definition.

## 9.5 Hypersurface orthogonal vector fields

Given a vector field  $\vec{V}$  it identifies a **congruence of worldlines**, i.e. the set of curves to which the vector is tangent at any point of the considered region. If there exists a family of

surfaces  $f(x^\mu) = \text{const}$  such that at each point the worldlines are perpendicular to that surface, we say that  $\vec{V}$  is **hypersurface orthogonal**. If this is the case,  $\vec{V}$  should be parallel to the gradient of the family of surfaces. Let us clarify what do we mean. As we described in Chapter 3, section 5, the gradient of a surface  $f(x^\mu)$  is a one-form

$$\tilde{d}f \rightarrow \left( \frac{\partial f}{\partial x^0}, \frac{\partial f}{\partial x^1}, \dots, \frac{\partial f}{\partial x^n} \right) = \{f, \alpha\}. \quad (9.39)$$

When we say that  $\vec{V}$  must be parallel to  $\tilde{d}f$  we mean that the one-form dual to  $\vec{V}$ , i.e.  $\tilde{V} \rightarrow \{g_{\alpha\beta}V^\beta \equiv V_\alpha\}$  must satisfy the equation

$$\frac{\partial f}{\partial x^\alpha} = \lambda V_\alpha, \quad \text{or} \quad V_\alpha = \frac{1}{\lambda} f, \alpha, \quad (9.40)$$

where  $\lambda$  is a function of the coordinates  $\{x^\mu\}$ . If this is true, it follows that

$$\begin{aligned} V_{\alpha;\beta} - V_{\beta;\alpha} &= \left( \frac{f, \alpha}{\lambda} \right)_{;\beta} - \left( \frac{f, \beta}{\lambda} \right)_{;\alpha} \\ &= \frac{1}{\lambda} (f, \alpha; \beta - f, \beta; \alpha) + f, \alpha (\lambda^{-1})_{;\beta} - f, \beta (\lambda^{-1})_{;\alpha} = \\ &= \frac{1}{\lambda} (f, \alpha, \beta - f, \beta, \alpha - \Gamma^\mu{}_{\beta\alpha} f, \mu + \Gamma^\mu{}_{\alpha\beta} f, \mu) + f, \alpha \left( -\frac{\lambda, \beta}{\lambda^2} \right) - f, \beta \left( -\frac{\lambda, \alpha}{\lambda^2} \right) \\ &= V_\beta \frac{\lambda, \alpha}{\lambda} - V_\alpha \frac{\lambda, \beta}{\lambda}, \end{aligned} \quad (9.41)$$

i.e.

$$V_{\alpha;\beta} - V_{\beta;\alpha} = V_\beta \frac{\lambda, \alpha}{\lambda} - V_\alpha \frac{\lambda, \beta}{\lambda}. \quad (9.42)$$

If we now define the following quantity

$$\omega^\delta = \frac{1}{2} \epsilon^{\delta\alpha\beta\mu} V_{[\alpha;\beta]} V_\mu, \quad (9.43)$$

which we call *rotation*, remembering the definition of the antisymmetric unit pseudotensor  $\epsilon^{\delta\alpha\beta\mu}$  given in Appendix B, one can show that

$$\omega^\delta = 0. \quad (9.44)$$

This is the Frobenius theorem, which states the sufficient and necessary condition for  $\vec{V}$  to be a hypersurface-orthogonal vector field.

What do we do with hypersurface-orthogonal vectors? In general, if we have any vector field, for example a timelike vector field  $V^\alpha(x^\mu)$ , we can choose the worldlines of  $\vec{V}$  as coordinate lines such that at any point the vector field takes a very simple form

$$V^\alpha(x^\mu) \rightarrow (V^0(x^\mu), 0, 0, 0), \quad (9.45)$$

and by means of a coordinate transformation  $x^{0'} = x^{0'}(x^\mu)$  we can set  $V^0 = 1$ . (Similarly, if  $\vec{V}$  is spacelike we can set  $V^\alpha(x^\mu) \rightarrow (0, V^1(x^\mu), 0, 0)$ . If  $\vec{V}$  is the four-velocity of

some matter, we say that we choose a **comoving** coordinate system. It is always possible to choose coordinates such that  $\vec{V}$  takes the simple form (9.45), but the corresponding transformation for the dual one-form  $\tilde{V}$

$$V_\alpha(x^\mu) \rightarrow (V_0(x^\mu), 0, 0, 0), \quad (9.46)$$

is possible only if  $\vec{V}$  is hypersurface-orthogonal. In fact, eq. (9.46) is equivalent to  $V_\alpha = V_0 x_{,\alpha}^0$ , i.e. if (9.46) holds,  $\vec{V}$  is hypersurface-orthogonal and viceversa (remember that  $x_{,\beta}^\alpha = \delta_\beta^\alpha$ ). The existence of an hypersurface-orthogonal vector field allows to choose coordinates in such a way that the metric can be considerably simplified. Given a three-dimensional spacetime  $(x^0, x^1, x^2)$

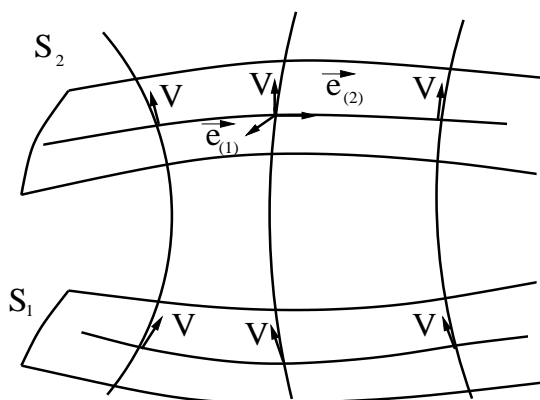

be  $S_1$  and  $S_2$  two of the family of surfaces  $f(x^\mu) = cost$ , to which  $\vec{V}$  is orthogonal. Let us assume, for example, that  $\vec{V}$  is timelike. We can choose  $\vec{e}_{(0)}$  parallel to  $\vec{V}$ , and the remaining basis vectors as the tangent vectors to some curves lying on the surface so that

$$\begin{aligned} g_{00} &= g(\vec{e}_{(0)}, \vec{e}_{(0)}) = \vec{e}_{(0)} \cdot \vec{e}_{(0)} \neq 0 \\ g_{0i} &= g(\vec{e}_{(0)}, \vec{e}_{(i)}) = 0, \quad i = 1, 2. \end{aligned} \quad (9.47)$$

Thus, the metric takes the form

$$ds^2 = g_{00}(dx^0)^2 + g_{ik}(dx^i)(dx^k), \quad i, k = 1, 3 \quad (9.48)$$

The generalization of this example to the four-dimensional spacetime is immediate, and the surface  $S$  will now be a hypersurface.

## 9.6 Appendix A

We want to show that eq. (9.10) is equivalent to eq. (9.11).

$$\begin{aligned} \xi_{\alpha;\beta} &= (g_{\alpha\mu}\xi^\mu)_{;\beta} \\ &= g_{\alpha\mu}\xi^\mu_{;\beta} = g_{\alpha\mu}(\xi^\mu_{;\beta} + \Gamma^\mu_{\delta\beta}\xi^\delta), \end{aligned} \quad (9.49)$$

hence

$$\begin{aligned}
\xi_{\alpha;\beta} + \xi_{\beta;\alpha} &= g_{\alpha\mu} \left( \xi_{,\beta}^{\mu} + \Gamma^{\mu}_{\delta\beta} \xi^{\delta} \right) \\
&+ g_{\beta\mu} \left( \xi_{,\alpha}^{\mu} + \Gamma^{\mu}_{\alpha\delta} \xi^{\delta} \right) \\
&= g_{\alpha\mu} \xi_{,\beta}^{\mu} + g_{\beta\mu} \xi_{,\alpha}^{\mu} + (g_{\alpha\mu} \Gamma^{\mu}_{\delta\beta} + g_{\beta\mu} \Gamma^{\mu}_{\alpha\delta}) \xi^{\delta}.
\end{aligned} \tag{9.50}$$

The term in parenthesis can be written as

$$\begin{aligned}
&\frac{1}{2} [g_{\alpha\mu} g^{\mu\sigma} (g_{\delta\sigma,\beta} + g_{\sigma\beta,\delta} - g_{\delta\beta,\sigma}) + g_{\beta\mu} g^{\mu\sigma} (g_{\alpha\sigma,\delta} + g_{\sigma\delta,\alpha} - g_{\alpha\delta,\sigma})] \\
&= \frac{1}{2} [\delta_{\alpha}^{\sigma} (g_{\delta\sigma,\beta} + g_{\sigma\beta,\delta} - g_{\delta\beta,\sigma}) + \delta_{\beta}^{\sigma} (g_{\alpha\sigma,\delta} + g_{\sigma\delta,\alpha} - g_{\alpha\delta,\sigma})] \\
&= \frac{1}{2} [g_{\delta\alpha,\beta} + g_{\alpha\beta,\delta} - g_{\delta\beta,\alpha} + g_{\alpha\beta,\delta} + g_{\beta\delta,\alpha} - g_{\alpha\delta,\beta}] \\
&= g_{\alpha\beta,\delta},
\end{aligned} \tag{9.51}$$

and eq. (9.50) becomes

$$\xi_{\alpha;\beta} + \xi_{\beta;\alpha} = g_{\alpha\mu} \xi_{,\beta}^{\mu} + g_{\beta\mu} \xi_{,\alpha}^{\mu} + g_{\alpha\beta,\delta} \xi^{\delta} \tag{9.52}$$

which coincides with eq. (9.10).

## 9.7 Appendix B: The Levi-Civita completely antisymmetric pseudotensor

We define the *Levi-Civita symbol* (also said *Levi-Civita tensor density*),  $e_{\alpha\beta\gamma\delta}$ , as an object whose components change sign under interchange of any pair of indices, and whose non-zero components are  $\pm 1$ . Since it is completely antisymmetric, all the components with two equal indices are zero, and the only non-vanishing components are those for which all four indices are different. We set

$$e_{0123} = 1. \tag{9.53}$$

Under general coordinate transformations,  $e_{\alpha\beta\gamma\delta}$  does not transform as a tensor; indeed, under the transformation  $x^{\alpha} \rightarrow x^{\alpha'}$ ,

$$\frac{\partial x^{\alpha}}{\partial x^{\alpha'}} \frac{\partial x^{\beta}}{\partial x^{\beta'}} \frac{\partial x^{\gamma}}{\partial x^{\gamma'}} \frac{\partial x^{\delta}}{\partial x^{\delta'}} e_{\alpha\beta\gamma\delta} = J e_{\alpha'\beta'\gamma'\delta'} \tag{9.54}$$

where  $J$  is defined (see Chapter 7) as

$$J \equiv \det \left( \frac{\partial x^{\alpha}}{\partial x^{\alpha'}} \right) \tag{9.55}$$

and we have used the definition of determinant.

We now define the *Levi-Civita pseudo-tensor* as

$$\epsilon_{\alpha\beta\gamma\delta} \equiv \sqrt{-g} e_{\alpha\beta\gamma\delta}. \tag{9.56}$$

Since, from (7.25), for a coordinate transformation  $x^\alpha \rightarrow x^{\alpha'}$

$$|J| = \frac{\sqrt{-g'}}{\sqrt{-g}}, \quad (9.57)$$

then

$$\epsilon_{\alpha\beta\gamma\delta} \rightarrow \epsilon_{\alpha'\beta'\gamma'\delta'} = \text{sign}(J) \frac{\partial x^\alpha}{\partial x^{\alpha'}} \frac{\partial x^\beta}{\partial x^{\beta'}} \frac{\partial x^\gamma}{\partial x^{\gamma'}} \frac{\partial x^\delta}{\partial x^{\delta'}} \epsilon_{\alpha\beta\gamma\delta}. \quad (9.58)$$

Thus,  $\epsilon_{\alpha\beta\gamma\delta}$  is not a tensor but a pseudo-tensor, because it transforms as a tensor times the sign of the Jacobian of the transformation. It transforms as a tensor only under a subset of the general coordinate transformations, i.e. that with  $\text{sign}(J) = +1$ .

Warning: do not confuse the Levi-Civita symbol,  $e_{\alpha\beta\gamma\delta}$ , with the Levi-Civita pseudo-tensor,  $\epsilon_{\alpha\beta\gamma\delta}$ .

# Chapter 10

## The Schwarzschild solution

The Schwarzschild solution was first derived by Karl Schwarzschild in 1916, although a complete understanding of the Schwarzschild spacetime was achieved much recently. The paper was communicated to the Berlin Academy by Einstein on 13 January 1916, just about two months after he had published the seminal papers on the theory of General Relativity. In those years Schwarzschild was very ill. He had contracted a fatal disease in 1915 while serving the German army at the eastern front. He died on 11 May 1916, and during his illness he wrote two papers in General Relativity, one describing the solution for the gravitational field exterior to a spherically symmetric non rotating body, which we are going to derive, and the second describing the interior solution for a star of constant density which we shall discuss later.

We now want to find an exact solution of Einstein's equations in vacuum, which is spherically symmetric and static. This will be the relativistic generalization of the newtonian solution for a pointlike mass

$$V = -\frac{GM}{r}, \quad (10.1)$$

and it will describe the gravitational field in the exterior of a non rotating body. Let us first discuss the symmetries of the problem.

### 10.1 The symmetries of the problem

a) *Symmetry with respect to time.*

Time-symmetric spacetimes can be stationary or static. A spacetime is said to be **stationary** if it admits a **timelike Killing vector**  $\vec{\xi}$ . It follows from the Killing equations that the metric of a stationary spacetime does not depend on time

$$\frac{\partial g_{\alpha\beta}}{\partial x^0} = 0. \quad (10.2)$$

A spacetime is **static** if it admits a **hypersurface-orthogonal, timelike Killing vector**. In this case, as shown in Chapter 12, we can choose the coordinates in such a way that

$\vec{\xi} \rightarrow (1, 0, 0, 0)$ , and the line-element takes the simple form

$$ds^2 = g_{00}(x^i)(dx^0)^2 + g_{kn}(x^i)dx^k dx^n, \quad i, k, n = 1, 3, \quad (10.3)$$

where  $g_{00} = g(\vec{\xi}, \vec{\xi}) = \vec{\xi} \cdot \vec{\xi}$ .

From this equation we see that the metric is not only independent on time, but also invariant under time reversal  $t \rightarrow -t$ . (If terms like  $dx^0 dx^i$  were present this would not be true).

b) *Spatial symmetry.*

We now take care of the spatial part of the metric. The basic idea is that we want to “fill” the space with concentric spherical surfaces. We start with the 2-sphere of radius  $a$  in flat space

$$ds_{(2)}^2 = g_{22}(dx^2)^2 + g_{33}(dx^3)^2 = a^2(d\theta^2 + \sin^2 \theta d\varphi^2). \quad (10.4)$$

The surface of this sphere is

$$A = \int \sqrt{g} d\theta d\varphi = \int_0^\pi a^2 \sin \theta d\theta \int_0^{2\pi} d\varphi = 4\pi a^2, \quad (10.5)$$

and the length of the circumference

$$\theta = \frac{\pi}{2}, \quad dl = a d\varphi, \quad C = 2\pi a. \quad (10.6)$$

These results continue to hold if  $a$  is an arbitrary function of the remaining coordinates  $x^0, x^1$

$$ds_{(2)}^2 = a^2(x^0, x^1)(d\theta^2 + \sin^2 \theta d\varphi^2). \quad (10.7)$$

But since we have already established that the metric does not depend on time, we put  $a = a(x^1)$ . We are now free to make a coordinate transformation and put

$$r = a(x^1). \quad (10.8)$$

Thus we **define** the radial coordinate as being the ratio between the surface and the circumference of the 2-sphere. However, it should be noted that in principle the coordinate  $r$  has nothing to do with the distance between the center of the sphere and the surface, as we shall later show.

Then we go to the next sphere at  $r + dr$ . We may label the points of the second sphere with different  $(\theta', \varphi')$  as indicated in the figure

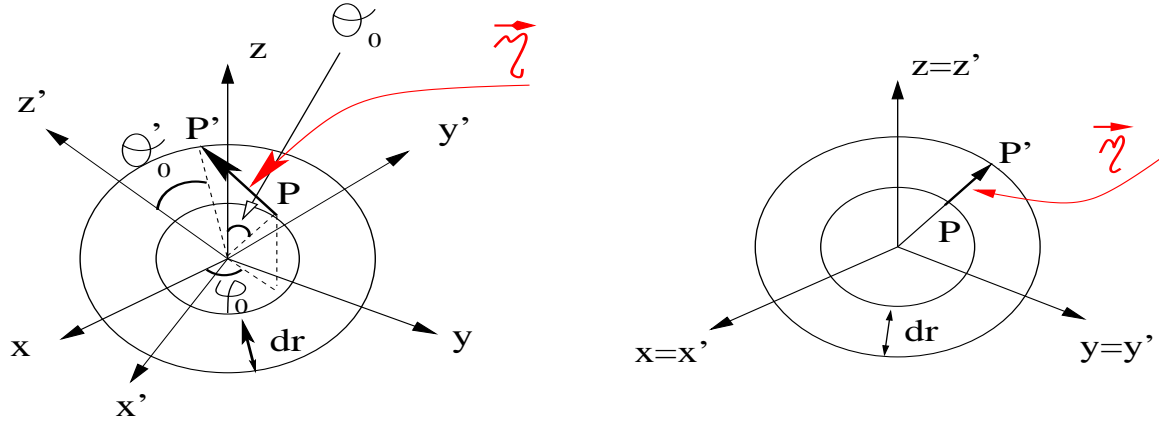

If the poles of the two spheres are not aligned, the vector  $\vec{\eta}$  which maps the point  $P = (\theta_0, \varphi_0)$  on the internal sphere ( $\theta_0, \varphi_0$  constants), to the point  $P' = (\theta'_0, \varphi'_0)$  on the external sphere (with  $\theta'_0 = \theta_0$  and  $\varphi'_0 = \varphi_0$ ), is directed as indicated in the figure. Conversely, if the poles are aligned  $\vec{\eta}$  is orthogonal to the two spheres, and therefore it is orthogonal to  $\frac{\partial}{\partial \theta} = \vec{e}_{(\theta)}$  and  $\frac{\partial}{\partial \varphi} = \vec{e}_{(\varphi)}$ , which are the basis vectors on the sphere. Thus in this case  $\vec{\eta}$  is **hypersurface-orthogonal**.

Since we want angular coordinates  $(\theta, \varphi)$  defined in a unique way on the whole set of spheres filling the space, we require that  $\vec{\eta}$  is indeed orthogonal to the spheres. In this case  $\vec{\eta}$  is the vector tangent to the coordinate line  $(\theta = \text{const}, \varphi = \text{const})$ , therefore  $\vec{\eta} = \frac{\partial}{\partial r} = \vec{e}_r$ . The orthogonality condition then gives

$$\vec{e}_r \cdot \vec{e}_\theta = g_{r\theta} = 0, \quad \vec{e}_r \cdot \vec{e}_\varphi = g_{r\varphi} = 0. \quad (10.9)$$

Under these assumptions, the metric of the three-space becomes

$$ds_{(3)}^2 = g_{rr} dr^2 + r^2(d\theta^2 + \sin^2 \theta d\varphi^2), \quad (10.10)$$

and that of the four-dimensional spacetime finally is

$$ds^2 = g_{00}(dx^0)^2 + g_{rr} dr^2 + r^2(d\theta^2 + \sin^2 \theta d\varphi^2). \quad (10.11)$$

At this point the two metric components  $g_{00}$  and  $g_{rr}$  should, in principle, depend on  $(r, \theta, \phi)$ . However, this is not the case. Indeed, if we consider a set of new polar coordinates  $(\theta', \phi')$  to label the points on the two spheres that fill the space, neither the vector  $\vec{e}_\theta$ , nor the vector  $\vec{e}_r$  will change and therefore they cannot depend on the angular coordinates we choose. As a consequence  $g_{00}$  and  $g_{rr}$  do not depend on  $(\theta, \phi)$  either, and we can write

$$g_{00} = g_{00}(r), \quad \text{and} \quad g_{rr} = g_{rr}(r).$$

It is convenient to rewrite the metric in the following form

$$ds^2 = -e^{2\nu}(dx^0)^2 + e^{2\lambda} dr^2 + r^2(d\theta^2 + \sin^2 \theta d\varphi^2), \quad (10.12)$$

where  $\nu = \nu(r)$  and  $\lambda = \lambda(r)$ . Let us now compute the distance between two points  $P1 = (x_*^0, r_1, \theta_*, \varphi_*)$ , and  $P2 = (x_*^0, r_2, \theta_*, \varphi_*)$

$$l = \int_{r_1}^{r_2} e^\lambda dr \quad (10.13)$$

(we can compute this finite length because we are in a time-independent spacetime). This distance **does not** coincide with  $(r_2 - r_1)$ .

We now write the components of the Einstein tensor in terms of the metric (10.13). They are

$$\begin{aligned} a) \quad G_{00} &= \frac{1}{r^2} e^{2\nu} \frac{d}{dr} \left[ r(1 - e^{-2\lambda}) \right] \\ b) \quad G_{rr} &= -\frac{1}{r^2} e^{2\lambda} \left[ (1 - e^{-2\lambda}) \right] + \frac{2}{r} \nu_{,r} \\ c) \quad G_{\theta\theta} &= r^2 e^{-2\lambda} \left[ \nu_{,rr} + \nu_{,r}^2 + \frac{\nu_{,r}}{r} - \nu_{,r} \lambda_{,r} - \frac{\lambda_{,r}}{r} \right] \\ d) \quad G_{\varphi\varphi} &= \sin^2 \theta G_{\theta\theta} \end{aligned} \quad (10.14)$$

The remaining components identically vanish. Since we are looking for a vacuum solution, the equations to solve are

$$G_{\mu\nu} = 0, \quad (10.15)$$

and eq. (10.14a) gives

$$r(1 - e^{-2\lambda}) = K, \quad (10.16)$$

where  $K$  is an integration constant. Hence

$$e^{2\lambda} = \frac{1}{1 - \frac{K}{r}}. \quad (10.17)$$

From eq. (10.14b) we find

$$\nu_{,r} = \frac{1}{2} \frac{K}{r(r - K)}, \quad (10.18)$$

and therefore

$$\nu = \frac{1}{2} \log \left( 1 - \frac{K}{r} \right) + \nu_0, \quad \rightarrow \quad e^{2\nu} = \left( 1 - \frac{K}{r} \right) e^{2\nu_0}, \quad (10.19)$$

where  $\nu_0$  is a constant. We can rescale the time coordinate

$$t \rightarrow e^{\nu_0} t,$$

in such a way that  $e^{2\nu}$  becomes

$$e^{2\nu} = 1 - \frac{K}{r}. \quad (10.20)$$

The final form of the solution is

$$ds^2 = - \left( 1 - \frac{K}{r} \right) c^2 dt^2 + \frac{1}{1 - \frac{K}{r}} dr^2 + r^2 (d\theta^2 + \sin^2 \theta d\varphi^2). \quad (10.21)$$

This is the **Schwarzschild solution**. When  $r \rightarrow \infty$  the metric reduces to that of a flat spacetime, therefore we say that the metric is **asymptotically flat**.

Now we want to understand what is the meaning of the integration constant  $K$ . In Chapter 8 section 1, we showed that in the weak-field limit, the geodesic equations reduce to the newtonian equations of motion, and consequently

$$g_{00} \sim - \left( 1 + \frac{2\Phi}{c^2} \right) = - \left( 1 - \frac{2GM}{c^2 r} \right), \quad \text{where} \quad (10.22)$$

$\Phi = -\frac{GM}{r}$  is the newtonian potential. From eq. (10.20) we see that when  $r \rightarrow \infty$   $g_{00}$  tends to unity as

$$-g_{00} = e^{2\nu} = 1 - \frac{K}{r}. \quad (10.23)$$

By comparing eq. (10.22) and (10.23) we find

$$K = \frac{2GM}{c^2}. \quad (10.24)$$

Therefore the constant  $K$  is the physical mass multiplied by  $\frac{2G}{c^2}$ . It is easy to check that the solution (10.21) satisfies eq. (10.14c).

## 10.2 The Birkhoff theorem

The solution (10.21) has been found by imposing that the spacetime is static and spherically symmetric, therefore it represents the gravitational field external to a non-rotating, spherically symmetric body whose structure is time-independent. However, it is more general than that. In fact Birkhoff's theorem establishes that it is the only spherically symmetric and asymptotically flat solution of the vacuum Einstein field equations. Let us assume that the functions  $(\nu, \lambda)$  in the metric (10.12) depend both on the radial coordinate **and** on time. To prove Birkhoff's theorem we only need the components  $R_{0r}$  and  $R_{\theta\theta}$  of the Ricci tensor:

$$\begin{aligned} a) \quad R_{0r} &= \frac{2}{r} \frac{\partial \lambda}{\partial x^0} = 0, \\ b) \quad R_{\theta\theta} &= 1 - e^{-2\lambda} \left[ 1 + r \frac{\partial(\nu - \lambda)}{\partial r} \right] = 0. \end{aligned} \quad (10.25)$$

From eq. (10.25a) it follows that  $\lambda$  must depend only upon the radial coordinate  $r$ . Then from eq. (10.25b) it follows that also  $\frac{\partial \nu}{\partial r}$  must be independent on  $x^0$  and consequently

$$\nu = \nu(r) + f(x^0). \quad (10.26)$$

This means that the coefficient of  $(dx^0)^2$  in the line element is  $e^{2\nu(r)} e^{2f(x^0)}$ . But the term  $e^{2f(x^0)}$  can be 'reabsorbed' by a coordinate transformation

$$dt' = e^{f(x^0)} dt, \quad (10.27)$$

so that the new metric coefficients are

$$\nu = \nu(r), \quad \lambda = \lambda(r), \quad (10.28)$$

and the metric is time independent. This means that even if we impose that the central object evolves in time, as it would be for example in the case of a star radially pulsating, or in a spherical collapse, we would find, in the exterior, the same Schwarzschild metric, and since the spacetime remains static even in these cases, gravitational waves could not be emitted. The conclusion is that spherically symmetric systems can never emit gravitational waves. A similar situation occurs in electrodynamics: a spherically symmetric distribution of charges and currents does not radiate.

### 10.3 Geometrized unities

From eq. (10.23) and (10.24) is easy to see that  $K = \frac{2GM}{c^2}$  must have the dimension of a length. In fact the ratio  $\frac{G}{c^2}$  is

$$\frac{G}{c^2} = 0.7425 \times 10^{-28} \text{cm} \cdot \text{g}^{-1}. \quad (10.29)$$

It is often convenient to put

$$G = c = 1, \quad (10.30)$$

which means that we measure the mass, as the lengths, in cm. We shall often adopt this convention, and we will indicate the geometrical mass (i.e. the mass in cm) as  $m$ .

In these unities the Schwarzschild solution becomes

$$ds^2 = - \left(1 - \frac{2m}{r}\right) dt^2 + \frac{1}{1 - \frac{2m}{r}} dr^2 + r^2 (d\theta^2 + \sin^2 \theta d\varphi^2). \quad (10.31)$$

### 10.4 The singularities of Schwarzschild solution

Let us examine the metric (10.31) in some more detail. We immediately see that there is a problem when  $r \rightarrow 2m$ :  $g_{00} \rightarrow 0$ , and  $g_{rr} \rightarrow \infty$ . Moreover, when  $r \rightarrow 0$ ,  $g_{00} \rightarrow \infty$ , and  $g_{rr} \rightarrow 0$ . In both cases we say that there is a singularity, but of a different nature. In order to check wheter a singularity is a genuine curvature singularity, we should compute the scalars which we can construct from the Riemann tensor and see if they diverge. To check whether the Riemann tensor is well-behaved is not enough, in fact for the Schwarzschild metric the components of  $R^\alpha_{\beta\gamma\delta}$  are

$$\begin{aligned} R^t_{\ rtr} &= -2 \frac{m}{r^3} \left(1 - \frac{2m}{r}\right)^{-1} \\ R^t_{\ \theta t\theta} &= \frac{1}{\sin^2 \theta} R^t_{\ \varphi t\varphi} = \frac{m}{r^5} \\ R^\theta_{\ \varphi\theta\varphi} &= 2 \frac{m}{r^5} \sin^2 \theta \\ R^r_{\ \theta r\theta} &= \frac{1}{\sin^2 \theta} R^r_{\ \varphi r\varphi} = -\frac{m}{r^5} \end{aligned} \quad (10.32)$$

and they diverge both at  $r = 0$ , and at  $r = 2m$ . However, if we compute the scalar invariants, like  $R^{abcd}R_{abcd}$ , we find that they diverge only at  $r = 0$ . We conclude that  $r = 0$  is a true curvature singularity, while  $r = 2m$  is only a *coordinate singularity*, due to an unappropriate choice of the coordinates.

We shall now analyse the properties of the surface  $r = 2m$ .

## 10.5 Spacelike, Timelike and Null Surfaces

In a curved background hypersurfaces are classified in the following way. Consider a generic hypersurface  $\Sigma$

$$\Sigma(x^\mu) = 0, \quad (10.33)$$

Be  $\vec{n}$  the normal vector dual to the gradient one-form

$$n_\alpha = \Sigma_{,\alpha} \quad (10.34)$$

If  $dx^\alpha$  is a displacement along the surface, it follows that

$$n_\alpha dx^\alpha = \Sigma_{,\alpha} dx^\alpha = d\Sigma = 0. \quad (10.35)$$

At any point of the hypersurface we can introduce a locally inertial frame, and rotate it in such a way that the components of  $\vec{n}$  are

$$n^\alpha = (n^0, n^1, 0, 0) \quad \text{and} \quad n_\alpha n^\alpha = (n^1)^2 - (n^0)^2. \quad (10.36)$$

Consider a vector  $t^\alpha$  tangent to  $\Sigma$  at the same point.  $t^\alpha$  must be orthogonal to  $\vec{n}$

$$n_\alpha t^\alpha = -n^0 t^0 + n^1 t^1 = 0 \quad \rightarrow \quad \frac{t^0}{t^1} = \frac{n^1}{n^0}. \quad (10.37)$$

From eq. (10.37) it follows that

$$t^\alpha = \Lambda(n^1, n^0, a, b) \quad \text{with } a, b \in \Lambda \quad \text{costant and arbitrary.} \quad (10.38)$$

Consequently the norm of  $\vec{t}$  is

$$t_\alpha t^\alpha = \Lambda^2[-(n^1)^2 + (n^0)^2 + (a^2 + b^2)] = \Lambda^2[-n_\alpha n^\alpha + (a^2 + b^2)]. \quad (10.39)$$

There are three possibilities:

- 1)  $n_\alpha n^\alpha < 0$ ,  $\rightarrow$   $n^\alpha$  is a timelike vector  $\rightarrow$   $\Sigma$  is **spacelike**
- 2)  $n_\alpha n^\alpha > 0$ ,  $\rightarrow$   $n^\alpha$  is a spacelike vector  $\rightarrow$   $\Sigma$  is **timelike**
- 3)  $n_\alpha n^\alpha = 0$ ,  $\rightarrow$   $n^\alpha$  is a null vector  $\rightarrow$   $\Sigma$  is **null**

We shall now see how the normal and the tangent vectors are directed in order to understand the disposition of the light-cones with respect to the hypersurface.

1) If  $n_\alpha n^\alpha < 0$ , then  $t_\alpha t^\alpha > 0$  and  $\vec{t}$  is spacelike. Consequently no tangent vector to  $\Sigma$  in P lies inside, or on the light-cone through P. Since a massive particle which starts

at P must move inside the light-cone (or on the light-cone if it is massless), this means that **a spacelike hypersurface can be crossed only in one direction.**

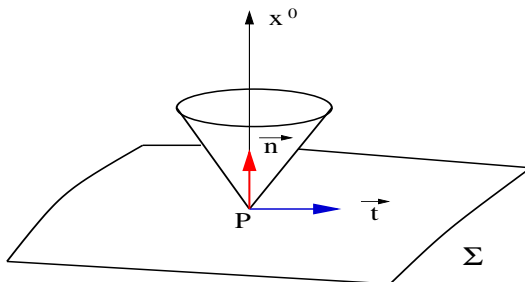

2) If  $n_\alpha n^\alpha > 0$ , then  $t_\alpha t^\alpha$  can be positive, negative or null depending on the value of  $a^2 + b^2$ . Therefore there will be some tangent vectors which lie inside the light-cone. Consequently a **timelike hypersurface can be crossed inward and outward.**

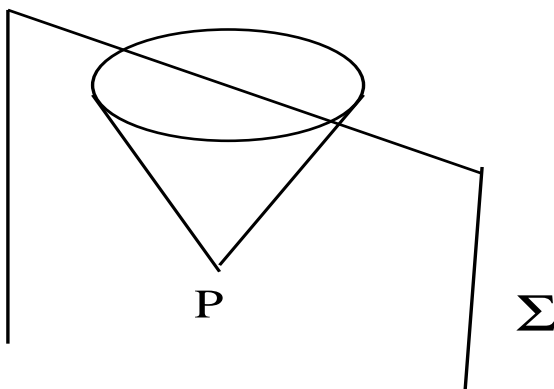

3) If  $n_\alpha n^\alpha = 0$ , then  $t_\alpha t^\alpha$  is positive ( $t^\alpha$  is spacelike), or null if  $a = b = 0$ . In this case there will be only one tangent vector (and all its multiples) at P which lies on  $\Sigma$  and on the light-cone

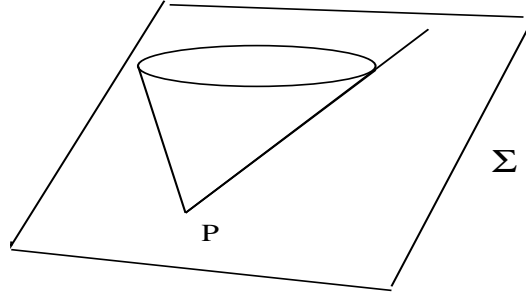

For example, in Minkowski spacetime  $t = const$  is a spacelike surface, and any physical object can pass it in only one direction without violating causality.  $x = const$  is a timelike surface, and physical objects can pass it in either direction,  $x - ct = 0$  is a null surface. Let us now try to understand what kind of surface  $r = 2m$  is.

Consider a generic hypersurface  $r = const$  in the Schwarzschild geometry

$$\Sigma = r - cost = 0. \tag{10.40}$$

The norm of the normal vector is

$$\begin{aligned} n_\alpha n^\alpha &= g^{\alpha\beta} n_\alpha n_\beta = g^{\alpha\beta} \Sigma_{,\alpha} \Sigma_{,\beta} = \\ &g^{00} \Sigma_{,0}^2 + g^{rr} \Sigma_{,r}^2 + g^{\theta\theta} \Sigma_{,\theta}^2 + g^{\varphi\varphi} \Sigma_{,\varphi}^2 = g^{rr} \Sigma_{,r}^2 = \left(1 - \frac{2m}{r}\right). \end{aligned} \tag{10.41}$$

From eq. (10.41) it follows that

$$\begin{aligned} r > 2m &\rightarrow n_\alpha n^\alpha > 0, & \Sigma &\text{ is timelike} \\ r = 2m &\rightarrow n_\alpha n^\alpha = 0, & \Sigma &\text{ is null} \\ r < 2m &\rightarrow n_\alpha n^\alpha < 0, & \Sigma &\text{ is spacelike} \end{aligned}$$

Consider for example  $S_1$  and  $S_2$  as shown in the following figure

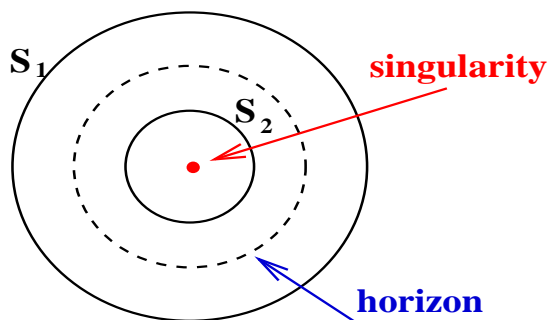

Any signal which starts at some point of  $S_1$  can be sent both toward the origin and outward, since  $S_1$  is timelike. Conversely, a signal which starts at a point of  $S_2$  in the interior of  $r = 2m$  must necessarily go inward, and be captured by the singularity at  $r = 0$ , since  $S_2$  is spacelike. The surface  $r = 2m$  is a null surface, which is basically the transition from spacelike to timelike hypersurface. On the surface at  $r = 2m$  the timelike Killing vector  $\vec{\xi}_{(t)}$  becomes null and it is spacelike for  $r < 2m$ .

The Schwarzschild solution is said to represent the gravitational field of a **black hole**, and the hypersurface  $r = 2m$  is called the **event horizon**. The reason for these names is that if we are outside  $r = 2m$  we can send a signal both inward and outward, but as soon as we cross the horizon any signal will inevitably bend toward the singularity: there is no way to know what happens inside the horizon.

As we mentioned before,  $r = 0$  is a genuine curvature singularity. Thus General Relativity predicts the existence of singularities hidden by a horizon.

## 10.6 How to remove a coordinate singularity

In general, it is not a simple problem to understand whether a singularity is a genuine curvature singularity or it is only a coordinate singularity. The first thing to do is to compute the Riemann tensor and the scalars which can be computed from it, like  $R^{abcd}R_{abcd}$  and check whether they diverge somewhere. If this is not the case, the singularity is due to a bad choice of the coordinate system, and a suitable choice of a new set of coordinates should remove it. If this can be done, we say that we are extending our original spacetime  $(M, g_{\alpha\beta})$  to a larger spacetime  $(\tilde{M}, \tilde{g}_{\alpha\beta})$  which includes the original one. Before analyzing the Schwarzschild case, let us consider two examples.

Consider the two-dimensional spacetime

$$ds^2 = -\frac{1}{t^4}dt^2 + dx^2, \quad 0 < t < \infty, \quad -\infty < x < \infty. \quad (10.42)$$

( $c = G = 1$ .) The metric is singular at  $t = 0$ . The coordinate transformation

$$t' = \frac{1}{t} \quad \rightarrow \quad dt' = -\frac{1}{t^2}dt, \quad (10.43)$$

gives

$$ds^2 = -(dt')^2 + dx^2, \quad (10.44)$$

Thus the metric (10.42) represents a flat spacetime. The metric (10.44) is defined for any  $t'$ , i.e.  $-\infty < t' < \infty$ , therefore it describes regions of the spacetime which were “unaccessible” to the coordinates (10.42). In fact in that case  $0 < t < \infty$ , which corresponds only to the section  $0 < t' < \infty$ , of our new spacetime. This is the reason why we say that the new coordinates provide an extension of the spacetime. The coordinate singularity  $t = 0$  is mapped onto the line  $t' \rightarrow \infty$ . The new spacetime is said to be **geodesically complete** because any geodesic which starts at any given point of the spacetime, can be extended for arbitrarily large values of the affine parameter. Conversely, the original spacetime (10.42) was **geodesically incomplete** for the following reason. We have established that the spacetime is flat, and it extends from  $-\infty$  to  $+\infty$  in both coordinates  $(t', x')$ . In eq. (10.42) we were trying to cover our infinite spacetime with coordinates which vary in a semi-infinite range ( $0 < t < \infty$ ). This is the reason why the singularity  $t = 0$  appears. With those coordinates we were able to cover only the region ( $0 < t' < \infty$ ) of the complete spacetime, but not the region ( $-\infty < t' < 0$ ). Consequently, geodesics which start in the region  $t' < 0$ , cross the axis and continue in the region  $t' > 0$ , cannot be completely represented in the spacetime described by  $(t, x)$ : they will terminate for a finite value of the proper time.

Another example is the Rindler spacetime, which has interesting similarities with the Schwarzschild geometry. The line-element is

$$ds^2 = -x^2 dt^2 + dx^2, \quad -\infty < t < \infty, \quad 0 < x < \infty. \quad (10.45)$$

The metric is singular at  $x = 0$ . The determinant  $g$  vanishes at  $x = 0$ , therefore  $g^{\mu\nu}$  is also singular. Let us consider geodesics in this spacetime. Since the metric is independent on time, it admits a timelike Killing vector  $\vec{\xi}_{(t)} \rightarrow (1, 0)$ . According to eq. (9.33)

$$\xi_{(t)\alpha} U^\alpha = g_{\alpha\beta} \xi_{(t)}^\alpha U^\beta = \text{const} = -E, \quad \rightarrow \quad U^0 = \frac{E}{x^2}, \quad (10.46)$$

where  $U^\beta = \frac{dx^\beta}{d\lambda}$  and  $\lambda$  is an affine parameter (not necessarily the proper time). Therefore,

$$\frac{dt}{d\lambda} = \frac{E}{x^2}. \quad (10.47)$$

Since the norm of the vector tangent to the worldline of a massive particle is  $-1$ , then

$$U^\mu U^\nu g_{\mu\nu} = -x^2 \left( \frac{dt}{d\lambda} \right)^2 + \left( \frac{dx}{d\lambda} \right)^2 = -1, \quad (10.48)$$

thus

$$\left( \frac{dx}{d\lambda} \right)^2 = x^2 \left( \frac{dt}{d\lambda} \right)^2 - 1 = \frac{E^2}{x^2} - 1. \quad (10.49)$$

Hence

$$\frac{dx}{d\lambda} = \pm \sqrt{\frac{E^2}{x^2} - 1}, \quad \rightarrow \quad \lambda = \int^x \frac{x dx}{\sqrt{E^2 - x^2}} = -\sqrt{E^2 - x^2} + const. \quad (10.50)$$

Thus a particle starting at some point  $x$  reaches  $x = 0$  in a finite interval of the affine parameter: Rindler spacetime is **geodesically incomplete**. However, since the Riemann tensor and the curvature scalars do not diverge at  $x = 0$ , there must exist a coordinate transformation which brings the metric into a non-singular form. Unfortunately a systematic approach to the problem of finding the “right” coordinates to extend the metric does not exist. We shall describe a procedure which is based on the behaviour of null geodesics. In two dimension the situation is easier, since null geodesics belong, *at least locally* to two classes: ingoing and outgoing. Two geodesics belonging to the same class cannot cross, because the two tangent vectors should coincide at that point, and consequently the two geodesic should coincide everywhere (remember that geodesics parallel-transport their own tangent vector).  
If

$$\vec{K} \rightarrow \left\{ \frac{dx^\mu}{d\lambda} \right\}, \quad (10.51)$$

is the vector tangent to the null geodesic whose affine parameter is  $\lambda$ , we must have that

$$g_{\mu\nu} K^\mu K^\nu = 0. \quad (10.52)$$

In the case we are considering it becomes

$$0 = g_{\mu\nu} K^\mu K^\nu = -x^2 \left( \frac{dt}{d\lambda} \right)^2 + \left( \frac{dx}{d\lambda} \right)^2, \quad (10.53)$$

from which we find

$$\left( \frac{dt}{dx} \right)^2 = \frac{1}{x^2}. \quad (10.54)$$

Therefore along the null geodesic

$$t = \pm \log x + const, \quad (10.55)$$

where the + identifies the outgoing geodesics and the - the ingoing geodesics. Accordingly, we define the null ingoing and outgoing coordinates as

$$u = t - \log x \quad \text{and} \quad v = t + \log x \quad (10.56)$$

and the metric in the new coordinates becomes

$$ds^2 = -e^{v-u} du dv. \quad (10.57)$$

The coordinates  $u$  and  $v$  vary in the range  $(-\infty, +\infty)$ , and they cover the original region  $x > 0$ , (they do not extend the spacetime yet!), thus we haven't solved the problem of eliminating the singularity. An extension of the spacetime can be accomplished if we reparametrize the null geodesics with new coordinates

$$\begin{aligned} U &= U(u) \\ V &= V(v). \end{aligned} \quad (10.58)$$

The form of the metric is so simple that we may define  $U$  and  $V$  immediately. But to have a feeling on what one should do in general we proceed in a more systematic way. From eqs. (10.46) and (10.51) it follows that for a massless particle

$$\xi_{(t)\alpha} K^\alpha = g_{\alpha\beta} \xi_{(t)}^\alpha K^\beta = \text{const} = -E, \quad \rightarrow \quad d\lambda = \frac{x^2}{E} dt. \quad (10.59)$$

Since  $dt = \frac{1}{2}d(u+v)$ , if we put  $u = \text{const}$  and move along a null direction parallel to the  $v$ -axis, i.e. along an outgoing null geodesic, eq. (10.59) becomes

$$\begin{aligned} d\lambda &= \frac{x^2}{2E} dv, \quad \text{or, since} \quad 2 \log x = v - u \rightarrow x = e^{\frac{v-u}{2}}, \\ \lambda &= \frac{1}{2E} \int e^{(v-u)} dv = C + \left( \frac{e^{-u}}{2E} \right) e^v, \end{aligned} \quad (10.60)$$

where  $C$  is a constant. If we shift  $\lambda \rightarrow \frac{\lambda-C}{\frac{e^{-u}}{2E}}$ , then the affine parameter along outgoing null geodesics becomes

$$\lambda_{out} = e^v. \quad (10.61)$$

Proceeding in a similar way we find that the affine parameter along ingoing null geodesics is

$$\lambda_{in} = -e^{-u}. \quad (10.62)$$

If we now choose

$$\begin{aligned} U &= -e^{-u} \\ V &= e^v, \end{aligned} \quad (10.63)$$

the metric becomes

$$\begin{aligned} ds^2 &= -dU dV, \quad \text{or if we put} \quad T = \frac{(U+V)}{2}, \quad X = \frac{(V-U)}{2} \\ ds^2 &= -dT^2 + dX^2, \end{aligned} \quad (10.64)$$

which is again a flat spacetime.

Summarying: 1) we find the equations for the ingoing and outgoing null geodesics, 2) we choose the affine parameters along these geodesics as coordinates, then we introduce  $X$  and  $T$ .

$U$  and  $V$  range between  $-\infty$  and  $+\infty$ . The original spacetime  $(x, t)$  coincides with the quadrant  $[U < 0, V > 0]$ , but since everything is regular at  $[U = 0, V = 0]$ , the metric is extended to the regions  $U > 0$ , and  $V < 0$ , which were not included before. The relation between the old and the new coordinates is

$$\begin{aligned} x &= (X^2 - T^2)^{\frac{1}{2}} \\ t &= \tanh^{-1}\left(\frac{T}{X}\right) = \frac{1}{2} \log\left(\frac{X+T}{X-T}\right) \end{aligned} \tag{10.65}$$

A picture of the spacetime is given in the following figure

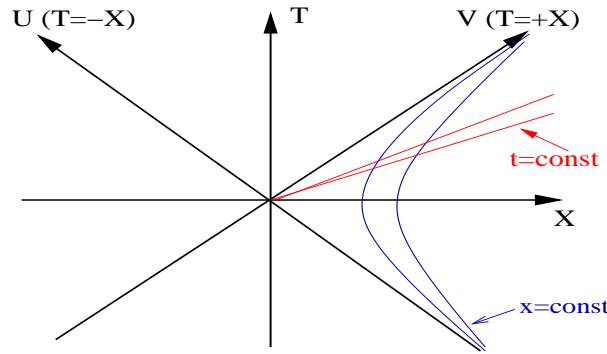

The singularity  $x = 0$  corresponds to the lines  $X = \pm T$ , where the metric in the new coordinates is perfectly well behaved. From the second of eqs. (10.65)

$$\begin{aligned} X = -T & \text{ corresponds to } t \rightarrow -\infty \\ X = T & \text{ corresponds to } t \rightarrow +\infty. \end{aligned} \tag{10.66}$$

The curves  $x = const$  are now mapped onto the hyperbolae  $X^2 - T^2 = const$ , while the curves  $t = const$  are mapped onto  $T = constX$ . The original Rindler space corresponds to the dashed region in the figure. Therefore we have finally extended the spacetime across the barrier  $x = 0$ .

If we now go back to Rindler's metric and consider the following coordinate transformation

$$y = \frac{1}{4}x^2, \tag{10.67}$$

the metric becomes

$$ds^2 = -4ydt^2 + \frac{1}{y}dy^2, \quad (10.68)$$

and rescaling the time coordinate  $t \rightarrow 2t$

$$ds^2 = -ydt^2 + \frac{1}{y}dy^2. \quad (10.69)$$

This is similar to the form of the two-dimensional  $(t, r)$  part of the Schwarzschild metric.

## 10.7 The Kruskal extension

First we compute the null geodesics of the two-dimensional Schwarzschild metric

$$ds^2 = \left(1 - \frac{2m}{r}\right) dt^2 + \frac{1}{1 - \frac{2m}{r}} dr^2 \quad (10.70)$$

by imposing

$$0 = g_{\mu\nu}K^\mu K^\nu = -\left(1 - \frac{2m}{r}\right) \left(\frac{dt}{d\lambda}\right)^2 + \left(1 - \frac{2m}{r}\right)^{-1} \left(\frac{dr}{d\lambda}\right)^2. \quad (10.71)$$

Hence

$$\left(\frac{dr}{dt}\right)^2 = \left(1 - \frac{2m}{r}\right)^2 \rightarrow \frac{dr}{dt} = \pm \frac{r}{r - 2m}, \quad (10.72)$$

whose solution is

$$t = \pm r_* + \text{const} \quad (10.73)$$

where

$$r_* = r + 2m \log\left(\frac{r}{2m} - 1\right), \quad \text{and} \quad \frac{dr}{dr_*} = \left(1 - \frac{2m}{r}\right). \quad (10.74)$$

The coordinate  $r_*$  is called the ‘‘tortoise’’ coordinate, since if  $r \rightarrow +\infty$  then  $r_* \sim r$ , but if  $r \rightarrow 2m$  then  $r_* \rightarrow -\infty$ , thus as  $r \rightarrow 2m$   $r_*$  pushes the horizon to  $-\infty$ . We now define the null ingoing and outgoing coordinates

$$\begin{aligned} u &= t - r_* & -\infty < u < +\infty, \\ v &= t + r_* & \rightarrow r_* = \frac{v-u}{2} & -\infty < v < +\infty \end{aligned} \quad (10.75)$$

and the two-dimensional metric becomes

$$\begin{aligned} ds^2 &= -\left(1 - \frac{2m}{r}\right) \left[ dt^2 - \frac{dr^2}{\left(1 - \frac{2m}{r}\right)^2} \right] = \\ &= -\left(1 - \frac{2m}{r}\right) [dt^2 - dr_*^2] = -\left(1 - \frac{2m}{r}\right) dudv. \end{aligned} \quad (10.76)$$

hence <sup>1</sup>

$$ds^2 = - \left(1 - \frac{2m}{r}\right) dudv = -\frac{2m}{r} e^{-\frac{r}{2m}} e^{\frac{v-u}{4m}} dudv. \quad (10.80)$$

Since  $r = 2m$  corresponds to  $u \rightarrow \infty$  and  $v \rightarrow -\infty$ , the metric (10.80) is regular everywhere. A comparison with the Rindler case shows that a convenient choice for  $U$  and  $V$  is

$$\begin{aligned} U &= -e^{-\frac{u}{4m}}, & \rightarrow & -\infty < U < 0 \\ V &= e^{\frac{v}{4m}}, & \rightarrow & 0 < V < +\infty \end{aligned} \quad (10.81)$$

The metric becomes

$$ds^2 = -\frac{32m^3 e^{-\frac{r}{2m}}}{r} dU dV. \quad (10.82)$$

The surface  $r = 2m$  now corresponds to  $U = 0$  or  $V = 0$  where the metric (10.82) is non-singular. Therefore it can be extended across these two hypersurfaces to cover the whole two-dimensional spacetime. By introducing the coordinates  $T$  and  $X$

$$T = \frac{V + U}{2} \quad X = \frac{V - U}{2} \quad (10.83)$$

the four-dimensional metric finally becomes

$$ds^2 = \frac{32m^3 e^{-\frac{r}{2m}}}{r} [-dT^2 + dX^2] + r^2 (d\theta^2 + \sin^2 \theta d\varphi^2). \quad (10.84)$$

This extension was independently found by Kruskal and Szekeres in 1960. The relation between the old and the new coordinates is <sup>2</sup>

---

<sup>1</sup>From the definition of  $r_*$  we find

$$\frac{r_* - r}{2m} = \log \left( \frac{r - 2m}{2m} \right) \rightarrow e^{\frac{r_* - r}{2m}} e^{-\frac{r}{2m}} = \frac{r - 2m}{2m}. \quad (10.77)$$

$$\left(1 - \frac{2m}{r}\right) = \frac{r - 2m}{2m} \frac{2m}{r} = \frac{2m}{r} e^{-\frac{r}{2m}} e^{\frac{r_*}{2m}}. \quad (10.78)$$

Since  $r_* = (v - u)/2$ , it follows

$$\left(1 - \frac{2m}{r}\right) = \frac{2m}{r} e^{-\frac{r}{2m}} e^{\frac{(v-u)}{4m}} \quad (10.79)$$

<sup>2</sup>The derivation of eqs. (10.85) and (10.86):

$$(X^2 - T^2) = \left(\frac{V - U}{2}\right)^2 - \left(\frac{V + U}{2}\right)^2 = -UV = +e^{-\frac{v-u}{4m}} = \frac{r}{2m} \left(1 - \frac{2m}{r}\right) e^{\frac{r}{2m}},$$

and

$$\log \left( \frac{X + T}{X - T} \right) = \log - \left( \frac{V}{U} \right) = \log e^{\frac{v-u}{4m}} = \frac{v + u}{4m} = \frac{t}{2m}.$$

$$(X^2 - T^2) = \left(\frac{r}{2m} - 1\right) e^{\frac{r}{2m}} \tag{10.85}$$

$$\frac{t}{2m} = \log\left(\frac{X+T}{X-T}\right) = 2 \tanh^{-1}\left(\frac{T}{X}\right) \tag{10.86}$$

The extended two-dimensional spacetime is shown in the following figure

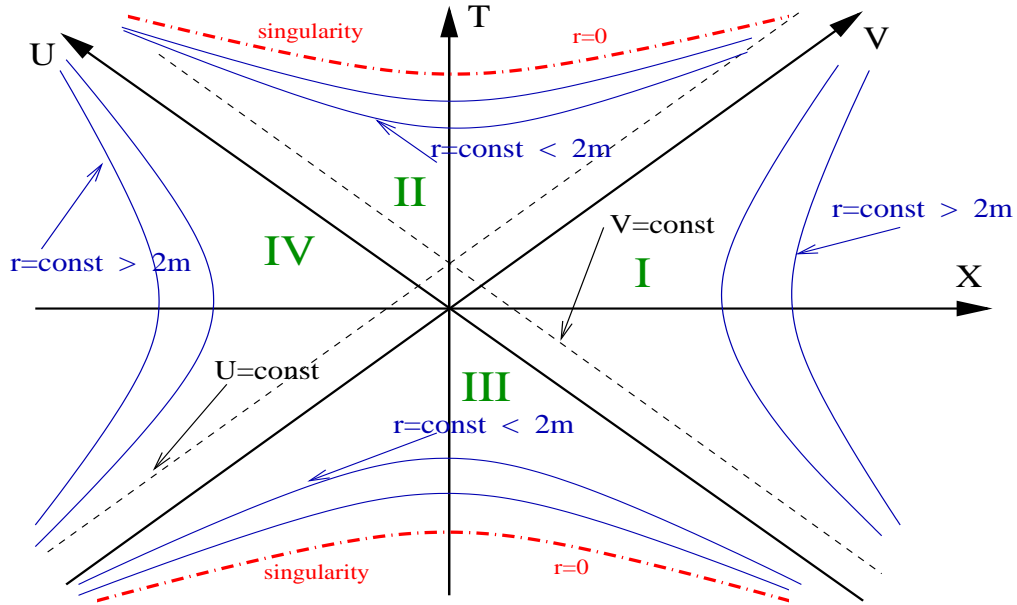

If  $r = \text{const} > 2m$ , from eq. (10.85) it follows that  $X^2 - T^2 > 0$  and constant, and consequently  $X = \pm\sqrt{T^2 + k}$ , where  $k = \left[\left(1 - \frac{2m}{r}\right) e^{\frac{r}{2m}}\right]_{r=\text{const}}$ . These curves are indicated as continuous lines in the quadrants I and IV of the preceding figure.

If  $r = \text{const} < 2m$ ,  $X^2 - T^2 < 0$  and constant, and  $X = \pm\sqrt{T^2 - |k|}$ . These curves are the dashed lines in the quadrants II and III. The curvature singularity  $r = 0$

corresponds to the curves  $X^2 - T^2 = -1$  and  $X = \pm\sqrt{T^2 - 1}$  also represented in regions II and III. Radial null geodesics correspond to  $U = \text{const}$  (ingoing) or to  $V = \text{const}$  (outgoing). This diagram has the remarkable property that null geodesics are  $45^\circ$ -straight lines. The curves  $t = \text{const}$  are straight lines passing through the origin.

The original spacetime ( $r > 0$ ), i.e. the Schwarzschild spacetime in the exterior of the horizon, corresponds to the quadrant  $[-\infty < U < 0, 0 < V < \infty]$ , labeled as region I. What is the meaning of the other regions? Consider a physical observer which starts at some point  $r$  in the exterior of the horizon, i.e. in region I, as indicated in the next figure

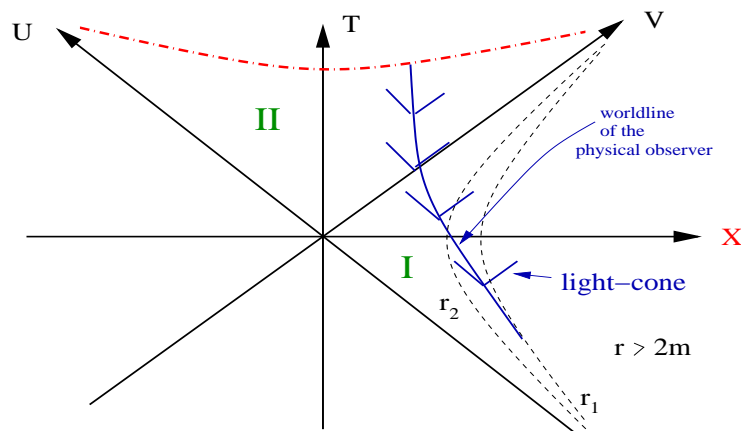

He can move only in the interior of the light-cones, which, at every point are  $45^\circ$ -straight lines. As one can see from the figure, as long as the observer is outside the horizon, he can still invert its direction of motion and escape free at infinity. But as soon as he crosses the surface  $U = 0$  and enters in region II, this is no longer possible, and he gets captured by the singularity  $r = 0$ , (compare with the discussion on the nature of the hypersurfaces  $r = \text{const}$  in section 10.5. The singularity  $r = 0$  is a spacelike singularity). Thus region II represents the spacetime in the interior of the horizon. Regions III and IV have the same characteristics as regions I and II, but they are time-reversed with respect to them: a particle in region III must necessarily have been emitted by the singularity sitting in that region. Then it will cross the surface  $r = 2m$  ( $U = 0$  or  $V = 0$ ) and will escape free at infinity either in region I, or in its mirror image region IV. It should be noted that region I and IV are causally unrelated, since a signal emitted by an observer in region I will never reach region IV and viceversa. It is interesting to ask whether regions IV and III do exist

or not. Suppose that a black hole has formed, and we really have a singularity concealed by a horizon. We live in the exterior of the horizon (we can move inward and outward). We can send signals to region II, but no signal emitted by us will reach regions III and IV for the reasons explained above. On the other hand, no signal coming from region IV can reach us. A signal emitted in region III (the white hole region) might, in principle, reach region I. However it is reasonable to assume that the black hole has formed at some time as the result of some physical process (the collapse of a massive star, as we shall soon see), and since any signal emitted in region III would take an infinite time  $t$  to reach region I, region III cannot communicate with us. If we want to take a pragmatical point of view, we can conclude that since we cannot communicate with regions III and IV (and viceversa), they do not exist for us. To speculate on the existence of ‘other universes’, although intriguing, is outside the scope of this course.

The Kruskal extension is very useful to investigate the causal structure of the spacetime in the vicinity of the horizon. However it is inappropriate to describe the spacetime at infinity, due to the exponential behaviour of  $g_{TT}$  and  $g_{XX}$ .

# Chapter 11

## Experimental Tests of General Relativity

### 11.1 Gravitational redshift of spectral lines

First of all let us clarify the following point. When we measure a time interval, we use a clock, which is based on a periodic phenomenon, such as atomic oscillations or the oscillations of a quartz crystal. We choose as time unit the interval of proper time associated to the repetition of the periodic signal of the clock. Thus, if we are in a frame in which the clock is at rest, the interval of proper time between two ticks will be

$$dT \equiv \frac{1}{c} d\tau = \frac{1}{c} \sqrt{-g_{00}(x^\mu)} dx^0 = \sqrt{-g_{00}(x^\mu)} dt; \quad (11.1)$$

$g_{00}(x^\mu)$  is the metric coefficient computed at the clock position, and  $dt$  is the interval of *coordinate time* between the two ticks. Note that we are assuming that  $dT$  is very small, so that we can use the infinitesimal expression of proper time without integrating over the path. The clock can be used in any reference frame, with respect to which it may be moving; the interval of proper time between two ticks, of course, will be the same, but will depend on the metric

$$dT = \frac{1}{c} (-g_{\mu\nu} dx^\mu dx^\nu)^{1/2}. \quad (11.2)$$

Let us assume that  $dT$  has been written on the clock by the manufacturer; if the clock has a velocity  $\frac{dx^\alpha}{dt}$  with respect to the reference frame, we can also write

$$\frac{dT}{dt} = \frac{1}{c} \left[ -g_{\nu\mu} \frac{dx^\mu}{dt} \frac{dx^\nu}{dt} \right]^{1/2}. \quad (11.3)$$

$\frac{dT}{dt}$  is called *time dilation factor* in the frame  $\{x^\mu\}$ , and it depends both on the metric, and on the velocity of the clock with respect to the frame. It tells us what is the ratio between the interval of proper time between two events and the corresponding interval of coordinate time. If the clock is at rest with respect to  $\{x^\mu\}$ , this becomes

$$\frac{dT}{dt} = [-g_{00}]^{1/2}. \quad (11.4)$$

We shall now show that due to this factor, the frequency of signals detected at a given point different from the emission point, changes with respect to the emission frequency. Let us assume that we are in a stationary gravitational field, which implies that there exists a timelike Killing vector and that, by a suitable choice of coordinates, the metric can be made independent of time. In this case, the coordinate  $x^0$  will be referred to as a *universal time*. This choice is not univocal, because we can always shift the origin of time, and rescale  $x^0$  by an arbitrary constant. Be  $S$  a source of light signals and  $O$  an observer, located at two different points.

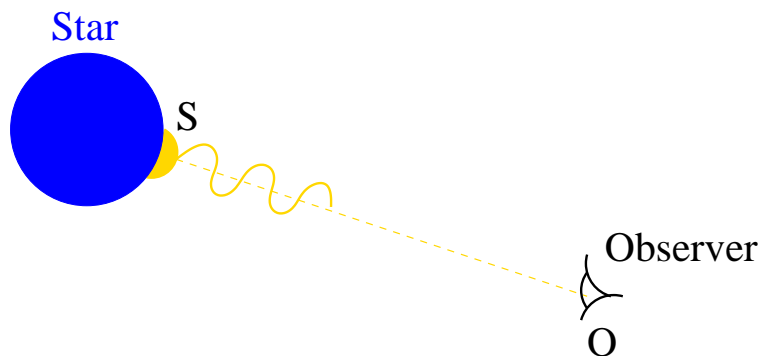

The source  $S$  emits a wave crest, which will reach  $O$  after an interval of coordinate time,  $\Delta x^0$ , which can be computed from

$$ds^2 = g_{00}(dx^0)^2 + 2g_{0i}dx^0 dx^i + g_{ik}dx^i dx^k = 0, \quad i, k = 1, 3$$

$$\Delta x^0 = \int dx^0 = \int \frac{-g_{0i}dx^i \pm \sqrt{(g_{0i}dx^i)^2 - g_{00}g_{ik}dx^i dx^k}}{g_{00}}$$

and the integral is computed along the path done by the light.<sup>1</sup> If  $S$  and  $O$  are at rest in a stationary field, the interval of coordinate time the light takes to go from  $S$  to  $O$  will be a constant, therefore if two wave crests are emitted at a time interval  $\Delta x_{em}^0$  by  $S$ , they will be reached by  $O$  with a time separation  $\Delta x_{obs}^0 = \Delta x_{em}^0$ . Now the period of the emitted wave  $\Delta T_{em}$  is the interval of *proper time* of the source  $S$ , which elapses between the emission of two wave crests, i.e.

$$\Delta T_{em} = [-g_{00}(x_{em}^\mu)]^{1/2} \Delta t_{em}$$

and the emission frequency is

$$\nu_{em} = \frac{1}{\Delta T_{em}} = \frac{1}{[-g_{00}(x_{em}^\mu)]^{1/2} \Delta t_{em}}$$

<sup>1</sup>Why do we have two solutions for  $\Delta x^0$  corresponding to the  $\pm$  sign? Firstly note that since  $g_{00}$  is negative and  $g_{ik}$  are positive  $\sqrt{(g_{0i}dx^i)^2 - g_{00}g_{ik}dx^i dx^k} > g_{0i}dx^i$ ; consequently the solution with the sign  $+$  is negative and that with the  $-$  is positive, i.e.  $(\Delta x^0)_+ < 0$  and  $(\Delta x^0)_- > 0$ . Clearly the physical solution is  $(\Delta x^0)_- > 0$ , whereas  $(\Delta x^0)_+ < 0$  would correspond to a signal that being emitted by  $O$  would reach  $S$  at  $x^0 = 0$ . The situation is not symmetric; indeed if we imagine that  $S$  is near a massive body and  $O$  is far away, in one case the signal would travel from  $S$  to  $O$  “against” the gravitational force, in the other case it would travel inward, from  $O$  to  $S$ , favoured by the gravitational attraction.

Similarly, the period measured by the observer will be the interval of its own *proper time*, which elapses between the detection of two wave crests, i.e.

$$\Delta T_{obs} = [-g_{00}(x_{obs}^\mu)]^{1/2} \Delta t_{obs}$$

and the observed frequency is

$$\nu_{obs} = \frac{1}{\Delta T_{obs}} = \frac{1}{[-g_{00}(x_{obs}^\mu)]^{1/2} \Delta t_{obs}}$$

Consequently

$$\frac{\nu_{obs}}{\nu_{em}} = \frac{\lambda_{em}}{\lambda_{obs}} = \frac{[-g_{00}(x_{em}^\mu)]^{1/2}}{[-g_{00}(x_{obs}^\mu)]^{1/2}}. \quad (11.5)$$

If the gravitational field is weak,

$$g_{00} \simeq - \left( 1 + \frac{2\Phi}{c^2} \right),$$

and

$$\begin{aligned} \frac{\nu_{obs} - \nu_{em}}{\nu_{em}} &= \frac{\lambda_{em} - \lambda_{obs}}{\lambda_{obs}} = \sqrt{\frac{1 + \frac{2\Phi_{em}}{c^2}}{1 + \frac{2\Phi_{obs}}{c^2}}} - 1 \simeq \\ &\sqrt{\left( 1 + \frac{2\Phi_{em}}{c^2} \right) \left( 1 - \frac{2\Phi_{obs}}{c^2} \right)} - 1 \simeq \sqrt{1 + \frac{2}{c^2} (\Phi_{em} - \Phi_{obs})} - 1 \\ &\simeq \frac{1}{c^2} (\Phi_{em} - \Phi_{obs}) \end{aligned}$$

and finally

$$\frac{\Delta\nu}{\nu} \simeq \frac{1}{c^2} (\Phi_{em} - \Phi_{obs}).$$

Remember that  $\Phi = -\frac{GM}{r}$ , where  $M$  is the mass of the body which generates the gravitational field. If, for example, we observe the light which is emitted by a star, since the gravitational field of the star near its surface is certainly much stronger than that of the Earth near the surface,

$$|\Phi_{em}| \gg |\Phi_{obs}|,$$

and consequently  $\Delta\nu < 0$ , i.e. the observed spectral lines will be shifted toward lower frequencies, i.e. the light will be *reddened*.

NOTE THAT: to derive the gravitational redshift, we have used only the fact that the effects of the gravitational field are described by the metric tensor, i.e. we have used basically only the Equivalence Principle.

Let us now consider the case when the source and the observer are located in the gravitational field of a Schwarzschild black hole; the ratio between the observed and the emitted frequency will be

$$\frac{\nu_{obs}}{\nu_{em}} = \sqrt{\frac{-g_{00}(x_{em}^\mu)}{-g_{00}(x_{obs}^\mu)}} = \sqrt{\frac{1 - \frac{2m}{r}}{-g_{00}(x_{obs}^\mu)}}; \quad (11.6)$$

as the source approaches the horizon  $r = 2m$ ,  $\nu_{obs}/\nu_{em} \rightarrow 0$ , i.e. the observed signal will fade away since the observed frequency tends to zero. Thus, the signal emitted by a source falling into a black hole has a distinctive feature, i.e. its frequency will progressively decrease tending to zero near the horizon.

**Some useful numbers:** for the Sun

$$M_{\odot} = 1.989 \cdot 10^{33} \text{ g}, \quad R_{\odot} = 6.9599 \cdot 10^5 \text{ km}; \quad (11.7)$$

$$\frac{GM_{\odot}}{c^2} = \frac{1.989 \cdot 10^{33} \times 6.673 \cdot 10^{-8}}{(2.998 \cdot 10^{10})^2} \sim 1.4768 \text{ km}, \quad \frac{GM_{\odot}}{R_{\odot}c^2} \sim 0.21 \cdot 10^{-5}. \quad (11.8)$$

For a neutron star

$$M \sim 1.4 M_{\odot}, \quad R \sim 10 \text{ km}, \quad \frac{GM}{Rc^2} \sim 0.21. \quad (11.9)$$

## 11.2 The geodesic equations in the Schwarzschild background

### 11.2.1 Geodesics from a variational principle

The geodesic equations can be derived, besides from the Equivalence Principle as shown in previous chapters, from a variational principle, by defining the Lagrangian

$$\mathcal{L} \left( x^{\alpha}, \frac{dx^{\alpha}}{d\lambda} \right) = \frac{1}{2} \left( g_{\mu\nu}(x^{\alpha}) \frac{dx^{\mu}}{d\lambda} \frac{dx^{\nu}}{d\lambda} \right) \quad (11.10)$$

in the space of the curves  $\{x^{\mu}(\lambda), \lambda \in [\lambda_0, \lambda_1]\}$ , and the action

$$S = \int \mathcal{L} \left( x^{\alpha}, \frac{dx^{\alpha}}{d\lambda} \right) d\lambda = \frac{1}{2} \int g_{\mu\nu}(x^{\alpha}) \frac{dx^{\mu}}{d\lambda} \frac{dx^{\nu}}{d\lambda} d\lambda.$$

$\lambda$  can be the proper time if we consider massive particles, or an affine parameter which parametrizes the geodesic, if we consider massless particles. By varying this action with respect to the coordinates, and setting the variation equal to zero, the Euler-Lagrangian equations are:

$$\frac{\partial \mathcal{L}}{\partial x^{\sigma}} - \frac{d}{d\lambda} \frac{\partial \mathcal{L}}{\partial \left( \frac{dx^{\sigma}}{d\lambda} \right)} = 0. \quad (11.11)$$

In fact, by varying a curve  $x^{\mu}(\lambda)$

$$x^{\mu}(\lambda) \longrightarrow x^{\mu}(\lambda) + \delta x^{\mu}(\lambda)$$

with  $\delta x^{\mu}(\lambda_0) = \delta x^{\mu}(\lambda_1) = 0$ , the action variation is

$$\delta S = \int \left( \frac{\partial \mathcal{L}}{\partial x^{\sigma}} \delta x^{\sigma} + \frac{\partial \mathcal{L}}{\partial \left( \frac{dx^{\sigma}}{d\lambda} \right)} \frac{\delta dx^{\sigma}}{d\lambda} \right) d\lambda$$

$$\begin{aligned}
&= \int \left( \frac{\partial \mathcal{L}}{\partial x^\sigma} \delta x^\sigma + \frac{\partial \mathcal{L}}{\partial \left( \frac{dx^\sigma}{d\lambda} \right)} \frac{d\delta x^\sigma}{d\lambda} \right) d\lambda \\
&= \int \left( \frac{\partial \mathcal{L}}{\partial x^\sigma} \delta x^\sigma - \frac{d}{d\lambda} \frac{\partial \mathcal{L}}{\partial \left( \frac{dx^\sigma}{d\lambda} \right)} \delta x^\sigma \right) d\lambda,
\end{aligned}$$

which vanishes for all  $\delta x^\sigma$  if and only if eqs. (11.11) are satisfied.

The Euler–Lagrange equations for the action (11.10) are equivalent to the geodesic equations

$$\frac{du^\beta}{d\lambda} + \Gamma_{\mu\nu}^\beta u^\mu u^\nu = 0 \quad (11.12)$$

(where  $u^\mu \equiv \frac{dx^\mu}{d\lambda}$ ). In fact, substituting (11.10) in (11.11), we have

$$\begin{aligned}
&\frac{1}{2} \left( u^\mu u^\nu g_{\mu\nu,\alpha} - 2 \frac{d}{d\lambda} (g_{\mu\alpha} u^\mu) \right) \\
&= -g_{\mu\alpha} \frac{du^\mu}{d\lambda} - u^\mu u^\nu \frac{1}{2} (2g_{\mu\alpha,\nu} - g_{\mu\nu,\alpha}) \\
&= -g_{\mu\alpha} \frac{du^\mu}{d\lambda} - u^\mu u^\nu \frac{1}{2} (g_{\mu\alpha,\nu} + g_{\nu\alpha,\mu} - g_{\mu\nu,\alpha}),
\end{aligned}$$

and contracting with  $-g^{\alpha\beta}$  we find equation (11.12).

## 11.2.2 Geodesics in the Schwarzschild metric

For the Schwarzschild metric, the Lagrangian is

$$\mathcal{L} = \frac{1}{2} \left[ - \left( 1 - \frac{2m}{r} \right) \dot{t}^2 + \frac{\dot{r}^2}{\left( 1 - \frac{2m}{r} \right)} + r^2 \dot{\theta}^2 + r^2 \sin^2 \theta \dot{\phi}^2 \right],$$

(we put  $G = c = 1$ ), and a dot indicates differentiation with respect to  $\lambda$ . The equations of motion for  $\dot{t}$ ,  $\dot{\phi}$  and  $\dot{\theta}$  are:

1) Equation for  $\dot{t}$ :

$$\frac{\partial \mathcal{L}}{\partial t} - \frac{d}{d\lambda} \frac{\partial \mathcal{L}}{\partial (\dot{t})} = 0 \quad \rightarrow \quad \frac{d}{d\lambda} \left[ \left( 1 - \frac{2m}{r} \right) 2\dot{t} \right] = 0$$

i.e.

$$\dot{t} = \frac{const}{\left( 1 - \frac{2m}{r} \right)} = \frac{E}{\left( 1 - \frac{2m}{r} \right)},$$

It should be reminded that, since the Schwarzschild metric admits a timelike Killing vector  $\frac{\partial}{\partial t} \rightarrow \xi_t^\alpha = (1, 0, 0, 0)$ , then

$$g_{\alpha\beta} \xi_t^\alpha u^\beta = const \quad \rightarrow \quad - \left( 1 - \frac{2m}{r} \right) \xi^0 \dot{t} = const = -E$$

where  $u^\alpha = \frac{dx^\alpha}{d\lambda}$  is the four-velocity of the particle. Thus  $E$  represents the energy of the particle per unit mass at infinity.

2) Equation for  $\dot{\phi}$ :

in a similar way it is easy to show that

$$\dot{\phi} = \frac{\text{const}}{r^2 \sin^2 \theta} = \frac{L}{r^2 \sin^2 \theta},$$

and since there is also a spacelike Killing vector  $\frac{\partial}{\partial \phi} \rightarrow \xi_\phi^\alpha = (0, 0, 0, 1)$ , such that

$$g_{\alpha\beta} \xi_\phi^\alpha u^\beta = \text{const} \quad \rightarrow \quad r^2 \sin^2 \theta \xi_\phi^\phi \dot{\phi} = \text{const} \quad \rightarrow \quad L = \text{const},$$

$L$  can be interpreted as the angular momentum of the particle per unit mass.

3) Equation for  $\dot{\theta}$ :

$$\frac{\partial \mathcal{L}}{\partial \theta} - \frac{d}{d\lambda} \frac{\partial \mathcal{L}}{\partial (\dot{\theta})} = 0 \quad \rightarrow \quad \frac{d}{d\lambda} (r^2 \dot{\theta}) = r^2 \sin \theta \cos \theta \dot{\phi}^2.$$

Therefore the equation for  $\theta$  is

$$\ddot{\theta} = -\frac{2}{r} \dot{r} \dot{\theta} + \sin \theta \cos \theta \dot{\phi}^2. \quad (11.13)$$

We will prove that this equations implies that, as in Newtonian theory, orbits are planar.

Given the spherical symmetry, polar axes can be chosen in arbitrary way. We choose them such that, for a given value of the affine parameter, say  $\lambda = 0$ , the particle is on the equatorial plane  $\theta = \frac{\pi}{2}$  and its three-velocity  $(\dot{r}, \dot{\theta}, \dot{\phi})$  lays on the same plane, i.e.  $\dot{\theta}(\lambda = 0) = 0$ . Thus, we have to solve the following Cauchy problem

$$\begin{aligned} \ddot{\theta} &= -\frac{2}{r} \dot{r} \dot{\theta} + \sin \theta \cos \theta \dot{\phi}^2 \\ \dot{\theta}(\lambda = 0) &= 0 \\ \theta(\lambda = 0) &= \frac{\pi}{2} \end{aligned} \quad (11.14)$$

which admits an unique solution. Since

$$\theta(\lambda) \equiv \frac{\pi}{2} \quad (11.15)$$

satisfies the differential equation and the initial conditions, it must be *the* solution. Thus the orbit is plane and to hereafter we shall assume  $\theta = \frac{\pi}{2}$  and  $\dot{\theta} = 0$ .

4) Equation for  $\dot{r}$ :

it is convenient to derive this equation from the condition  $u_\alpha u^\alpha = -1$ , or  $u_\alpha u^\alpha = 0$ , respectively valid for massive and massless particles.

**A) massive particles:**

$$g_{\alpha\beta} u^\alpha u^\beta = -\left(1 - \frac{2m}{r}\right) \dot{t}^2 + \frac{\dot{r}^2}{\left(1 - \frac{2m}{r}\right)} + r^2 \dot{\theta}^2 + r^2 \sin^2 \theta \dot{\phi}^2 = -1 \quad (11.16)$$

which becomes, by substituting the equations for  $\dot{t}$  and  $\dot{\phi}$

$$\dot{r}^2 + \left(1 - \frac{2m}{r}\right) \left(1 + \frac{L^2}{r^2}\right) = E^2 \quad (11.17)$$

**B) massless particles:**

$$g_{\alpha\beta}u^\alpha u^\beta = -\left(1 - \frac{2m}{r}\right)\dot{t}^2 + \frac{\dot{r}^2}{\left(1 - \frac{2m}{r}\right)} + r^2\dot{\theta}^2 + r^2\sin^2\theta\dot{\phi}^2 = 0 \quad (11.18)$$

which becomes

$$\dot{r}^2 + \frac{L^2}{r^2}\left(1 - \frac{2m}{r}\right) = E^2. \quad (11.19)$$

Finally, the geodesic equations are:

**A) For massive particles:**

$$\theta = \frac{\pi}{2}, \quad \dot{t} = \frac{E}{\left(1 - \frac{2m}{r}\right)} \quad (11.20)$$

$$\dot{\phi} = \frac{L}{r^2}, \quad \dot{r}^2 = E^2 - \left(1 - \frac{2m}{r}\right)\left(1 + \frac{L^2}{r^2}\right)$$

**B) For massless particles:**

$$\theta = \frac{\pi}{2}, \quad \dot{t} = \frac{E}{\left(1 - \frac{2m}{r}\right)} \quad (11.21)$$

$$\dot{\phi} = \frac{L}{r^2}, \quad \dot{r}^2 = E^2 - \frac{L^2}{r^2}\left(1 - \frac{2m}{r}\right)$$

### 11.3 The orbits of a massless particle

Let us write the radial equation (11.19) in the following form

$$\dot{r}^2 = E^2 - V(r) \quad (11.22)$$

where

$$V(r) = \frac{L^2}{r^2}\left(1 - \frac{2m}{r}\right). \quad (11.23)$$

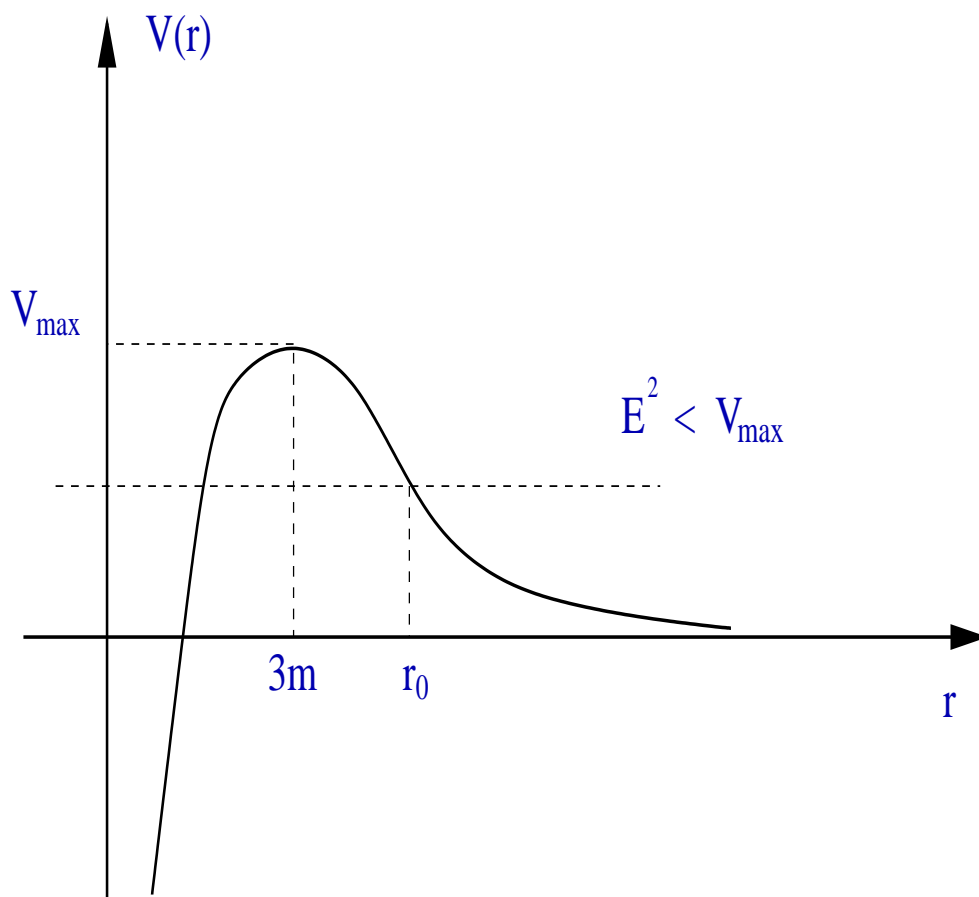

Note that:

- For massless particles the angular momentum  $L$  acts as a scale factor for the potential
- $V(r)$  tends to  $-\infty$  as  $r \rightarrow 0$ , and approaches zero at  $r \rightarrow \infty$
- $V(r)$  has only one maximum at  $r_{max} = 3m$ , where it takes the value

$$V_{max} = \frac{L^2}{27m^2} \quad (11.24)$$

It is useful to consider also the radial acceleration, obtained by differentiating eq. (11.22) with respect to  $\lambda$

$$2\dot{r}\ddot{r} = -\frac{dV(r)}{dr}\dot{r} \quad \rightarrow \quad \ddot{r} = -\frac{1}{2}\frac{dV(r)}{dr}. \quad (11.25)$$

Let us assume that the particle, say a photon, starts its path from  $+\infty$  with  $\dot{r} < 0$ . The energy of the particle can be:

1)  $\mathbf{E^2 > V_{max}}$

according to eq. (11.22)  $\dot{r}^2 > 0$  always, and the particle falls into the central body with increasing radial velocity, possibly making several revolutions around the central body before falling in.

2)  $\mathbf{E^2 = V_{max}}$

as the particle approaches  $r_{max}$ ,  $|\dot{r}|$  decreases and becomes zero at  $r = r_{max}$ . Since at  $r = r_{max}$  the radial acceleration is zero (see eq. 11.25), the particle remains trapped into the circular orbit with radius  $r = r_{max}$ . This is, however, an unstable orbit; indeed if the position is perturbed, the particle will

- either fall into the central body; this happens when the radial coordinate of the particle is displaced to  $r < r_{max}$ , since there the radial acceleration is negative
- or escape toward infinity; this happens when the radial coordinate is displaced to  $r > r_{max}$ , since there the radial acceleration is positive.

Thus, for massless particles, there exists only one *circular, unstable* orbit, and for this orbit

$$E^2 = \frac{L^2}{27m^2}. \quad (11.26)$$

### 3) $E^2 < V_{max}$

for  $r < r_0$ ,  $\dot{r}^2$  is always positive and becomes zero at  $r = r_0$ . This is a *turning point*: the particle cannot penetrate the potential barrier and reach values of  $r < r_0$  because  $\dot{r}$  would become imaginary; since at  $r = r_0$  the radial acceleration is positive, the particle is forced to invert its radial velocity and it escapes toward infinity on an open trajectory.

Thus, according to General relativity a light ray is deflected by the gravitational field of a massive body, provided its energy satisfies the following condition

$$E^2 < \frac{L^2}{27m^2}. \quad (11.27)$$

## 11.3.1 The deflection of light

We shall now compute the deflection angle that a massive body induces on the trajectory of a massless particle, say a photon. Referring to the figure 11.1, we shall use the following notation:

$r$  is the radial coordinate of the particle in a frame centered in the center of attraction;  $r$  forms an angle  $\phi$  with the y-axis.

$b$  is the *impact parameter*, i.e. the distance between the direction of the incoming particle (dashed vertical line) and the center of attraction.

$\delta$  is the deflection angle which we are going to evaluate: it is the angle between the incoming direction and the outgoing direction (dashed, green line)

Note that, since the Schwarzschild metric is invariant under time reflection, the particle can go through the red trajectory on the figure either in the direction indicated by the red arrow, or in the opposite one. Thus, the trajectory must be symmetric. The periastron is indicated in the figure as  $r_0$ .

We choose the orientation of the frame axes such that the initial value of  $\phi$  when the particle starts its motion at radial infinity be

$$\phi^{in} = 0. \quad (11.28)$$

The outgoing particle will escape to  $r \rightarrow \infty$  at

$$\phi^{out} = \pi + \delta. \quad (11.29)$$

Our only assumption will be that, for all values of  $r$  reached by the particle,

$$\frac{m}{r} \ll 1. \quad (11.30)$$

This condition is satisfied, for instance, in the case of a photon deflected by the Sun; indeed, if  $R_s$  is the radius of the Sun, then  $r \geq R_s$ , and

$$\frac{m}{r} \leq \frac{m}{R_s} \sim 10^{-6}. \quad (11.31)$$

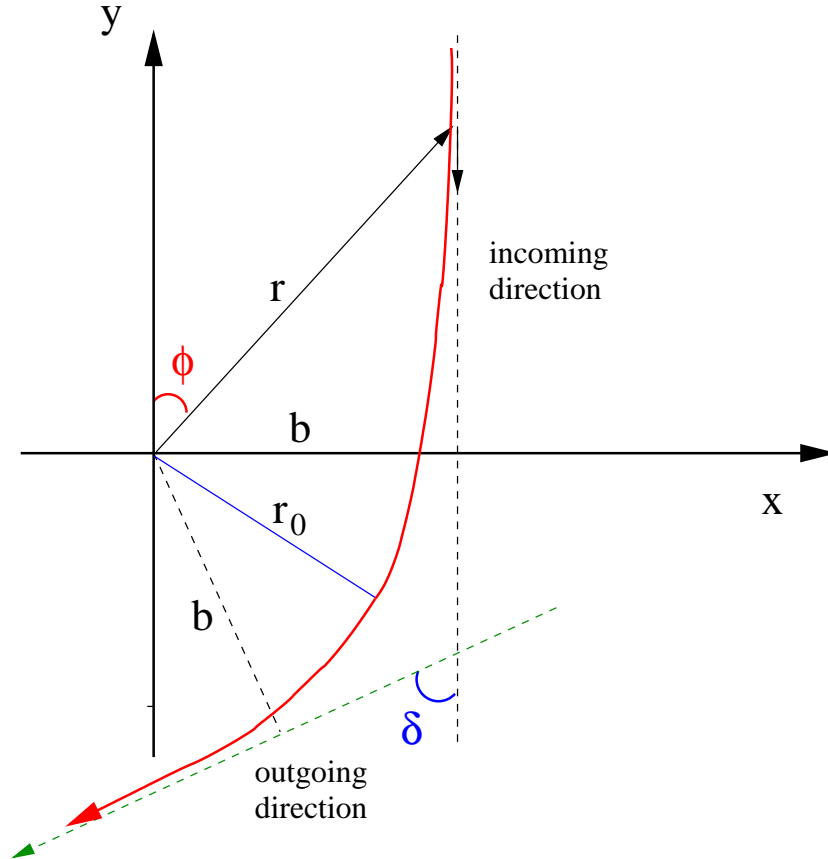

Figure 11.1:

From the figure we see that

$$b = \lim_{\phi \rightarrow 0} r \sin \phi. \quad (11.32)$$

We shall now express the impact parameter  $b$  in terms of the energy and the angular momentum of the particle.

When the particle arrives from infinity,  $r$  is large,  $\phi \simeq 0$  and

$$b \simeq r\phi \quad \rightarrow \quad \frac{d\phi}{dr} \simeq -\frac{b}{r^2}. \quad (11.33)$$

$\frac{d\phi}{dr}$  can also be derived combining together the third and the fourth eqs. (11.21)

$$\frac{d\phi}{dr} = \pm \frac{L}{r^2 \sqrt{E^2 - V(r)}}; \quad (11.34)$$

taking the limit for  $r \rightarrow \infty$  it gives

$$\frac{d\phi}{dr} \sim \pm \frac{L}{r^2 E}, \quad (11.35)$$

thus, combining together eqs. (11.33) and (11.35), we find that  $b$  can be written as

$$b \sim \frac{L}{E}. \quad (11.36)$$

In order the particle being deflected its energy must satisfy eq. (11.27), and this imposes a constraint on  $b$ , i.e.

$$b \geq \sqrt{27}m \equiv b_{crit}; \quad (11.37)$$

if  $b$  is smaller than this critical value, the particle is captured by the central body.

To find the deflection angle, let us consider the third and the fourth eqs. (11.21); we introduce a new variable

$$u \equiv \frac{1}{r}; \quad (11.38)$$

by construction, it must be

$$u(\phi = 0) = 0. \quad (11.39)$$

Furthermore,  $u$  must also vanish when  $\phi = \pi + \delta$ , because this value of  $\phi$  corresponds to the particle escaping to infinity.

In terms of the variable  $u$ , the third equation (11.21) for  $\dot{\phi}$  becomes

$$\dot{\phi} = Lu^2.$$

By indicating with a prime differentiation with respect to  $\phi$  we find that

$$\dot{r} = r' \dot{\phi} = -\frac{1}{u^2} u' \dot{\phi} = -Lu'.$$

By substituting this expression in the fourth eq. (11.21), it becomes

$$L^2(u')^2 + u^2 L^2 - 2mL^2 u^3 = E^2,$$

and differentiating with respect to  $\phi$ ,

$$2L^2 u'' u' + 2u u' L^2 - 6ML^2 u' u^2 = 0.$$

Dividing by  $2L^2 u'$ , we finally find the equation  $u$  must satisfy

$$u'' + u - 3mu^2 = 0, \quad (11.40)$$

to which we associate the boundary condition

$$\begin{aligned} u(\phi = 0) &= 0 \\ u'(\phi = 0) &= -\frac{1}{b}. \end{aligned} \quad (11.41)$$

The second condition is obtained by the relation

$$u(\phi \simeq 0) = \frac{1}{b} \sin \phi$$

which derives from eq. (11.32).

If the mass of the central body vanishes, equations (11.40) becomes

$$u'' + u = 0 \tag{11.42}$$

the solution of which

$$u(\phi) = \frac{1}{b} \sin \phi \quad \rightarrow \quad b = r \sin \phi \tag{11.43}$$

describes the trajectory of a particle which is not deflected.

If there is a central body with a finite mass  $m$ , the solution of (11.40) is different from (11.43), and the light ray is deflected. We note that equations (11.40) and (11.42) differ by a term,  $3mu^2$ , which is much smaller than, say, the term  $u$  by a factor

$$\frac{3mu^2}{u} = \frac{3m}{r} \ll 1. \tag{11.44}$$

Consequently, it is appropriate to solve eq. (11.40) using a perturbative approach; we shall proceed as follows. We put

$$u = u^{(0)} + u^{(1)} \tag{11.45}$$

where  $u^{(0)}$  is the solution of equation (11.42),

$$u^{(0)} \equiv \frac{1}{b} \sin \phi \tag{11.46}$$

and we assume that

$$u^{(1)} \ll u^{(0)}. \tag{11.47}$$

Since the term  $3mu^2$  is of higher order with respect to  $m/r$ , to lowest order in  $m/r$  equation (11.40) can be written as

$$u'' + u - 3m(u^{(0)})^2 = 0. \tag{11.48}$$

Consequently,

$$u'' + u = \frac{3m}{b^2} \sin^2 \phi = \frac{3m}{2b^2} (1 - \cos 2\phi). \tag{11.49}$$

We now substitute in this equation  $u = u^{(0)} + u^{(1)}$ , and since  $u^{(0)}$  satisfies eq. (11.42), we find

$$(u^{(1)})'' + u^{(1)} = \frac{3m}{2b^2} (1 - \cos 2\phi). \tag{11.50}$$

The solution of (11.50) which satisfies the boundary conditions (11.42) is

$$u_1 = \frac{3m}{2b^2} \left( 1 + \frac{1}{3} \cos 2\phi - \frac{4}{3} \cos \phi \right), \tag{11.51}$$

as can be checked by direct substitution. It should be noticed that the boundary conditions (11.42) must be satisfied by the complete solution  $u = u^{(0)} + u^{(1)}$ . Therefore,

$$u = \frac{1}{b} \sin \phi + \frac{3m}{2b^2} \left( 1 + \frac{1}{3} \cos 2\phi - \frac{4}{3} \cos \phi \right). \quad (11.52)$$

We now want to find the deflection angle, i.e., the small angle  $\delta$  such that  $u(\pi + \delta) = 0$ . By substituting  $\phi = \pi + \delta$  in (11.52) we finally find

$$u(\pi + \delta) \simeq -\frac{\delta}{b} + \frac{3m}{2b^2} \cdot \frac{8}{3} \quad (11.53)$$

which vanishes for

$$\delta = \frac{4m}{b}. \quad (11.54)$$

For a light ray which passes close to the surface of the Sun

$$\delta \sim 1.75 \text{ seconds of arc} \quad (11.55)$$

The first measurement of the deflection of light was done by Eddington, Dayson and Davidson during the solar eclipse in 1919. What was measured was the apparent position of a star behind the Sun (see figure) during the eclipse, when some light coming from the star was able to reach the Earth because the luminosity of the Sun was obscured by the eclipse. Comparing this apparent position with the position of the star as measured when the Earth is on the opposite side of its orbit around the Sun, one finds  $\delta\phi$ . The deflection was measured with an accuracy of about 10% at that time. Today, the bending of radio waves by quasars has been measured with an accuracy of 1%.

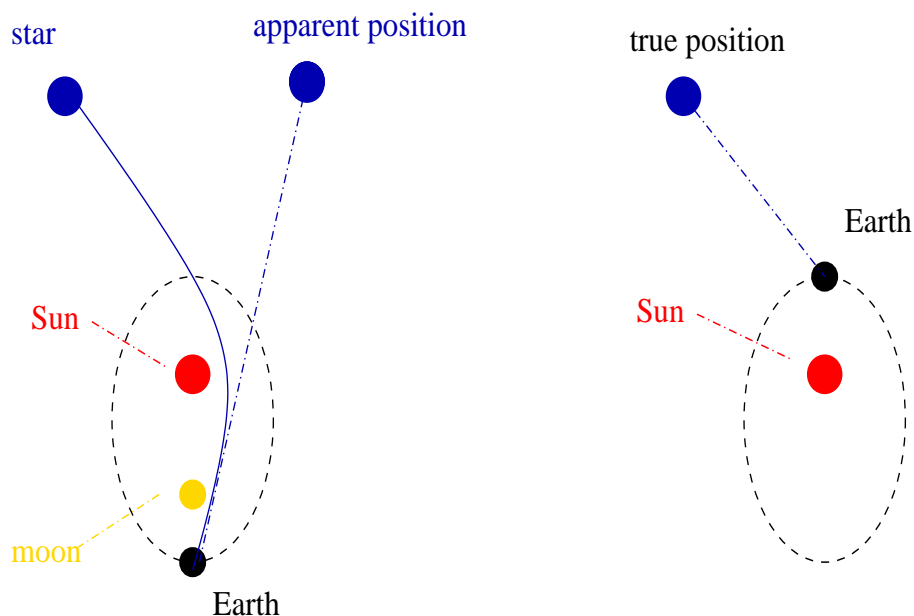

## 11.4 The orbits of a massive particle

Let us first discuss the orbits that a massive particle is allowed to move on. The equations of motion are

$$\begin{aligned} \theta &= \frac{\pi}{2}, & \dot{t} &= \frac{E}{\left(1 - \frac{2m}{r}\right)} \\ \dot{\phi} &= \frac{L}{r^2}, & \dot{r}^2 &= E^2 - \left(1 - \frac{2m}{r}\right) \left(1 + \frac{L^2}{r^2}\right). \end{aligned} \quad (11.56)$$

Let us study the radial equation

$$\dot{r}^2 = E^2 - V(r), \quad (11.57)$$

where

$$V(r) = \left(1 - \frac{2m}{r}\right) \left(1 + \frac{L^2}{r^2}\right). \quad (11.58)$$

First of all we note that, contrary to the massless case, the potential does not scale with the angular momentum and that  $V(r) \rightarrow 1$  when  $r \rightarrow \infty$ . To plot the potential, let us first see if it admits a minimum or a maximum by solving

$$\frac{\partial V}{\partial r} = \frac{mr^2 - L^2r + 3mL^2}{r^4} = 0;$$

this equation has two roots

$$r_{\pm} = \frac{L^2 \pm \sqrt{L^4 - 12m^2L^2}}{2m}. \quad (11.59)$$

If  $L^2 < 12m^2$  the roots are complex and there are no extrema; the potential will have the shape shown in the figure

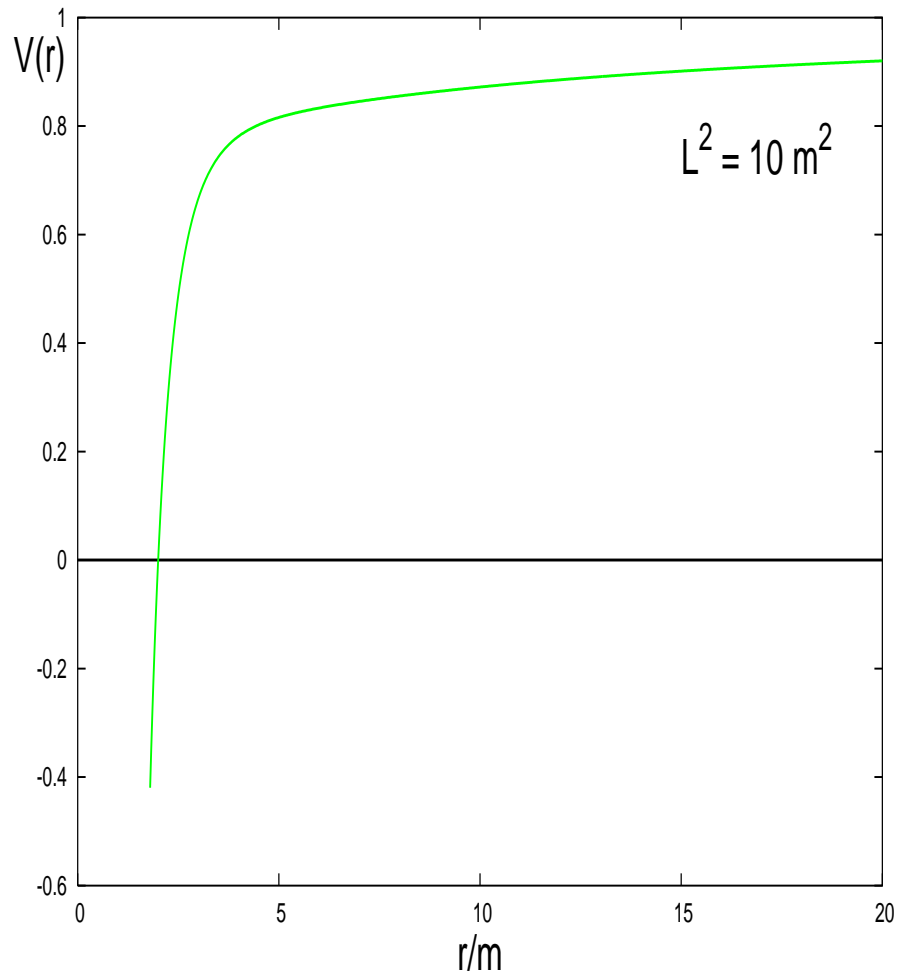

from which is clear that a particle arriving from infinity with  $\dot{r} \leq 0$  and having  $L^2 < 12m^2$  will be captured by the black hole.

If  $L^2 > 12m^2$  the potential has the following form

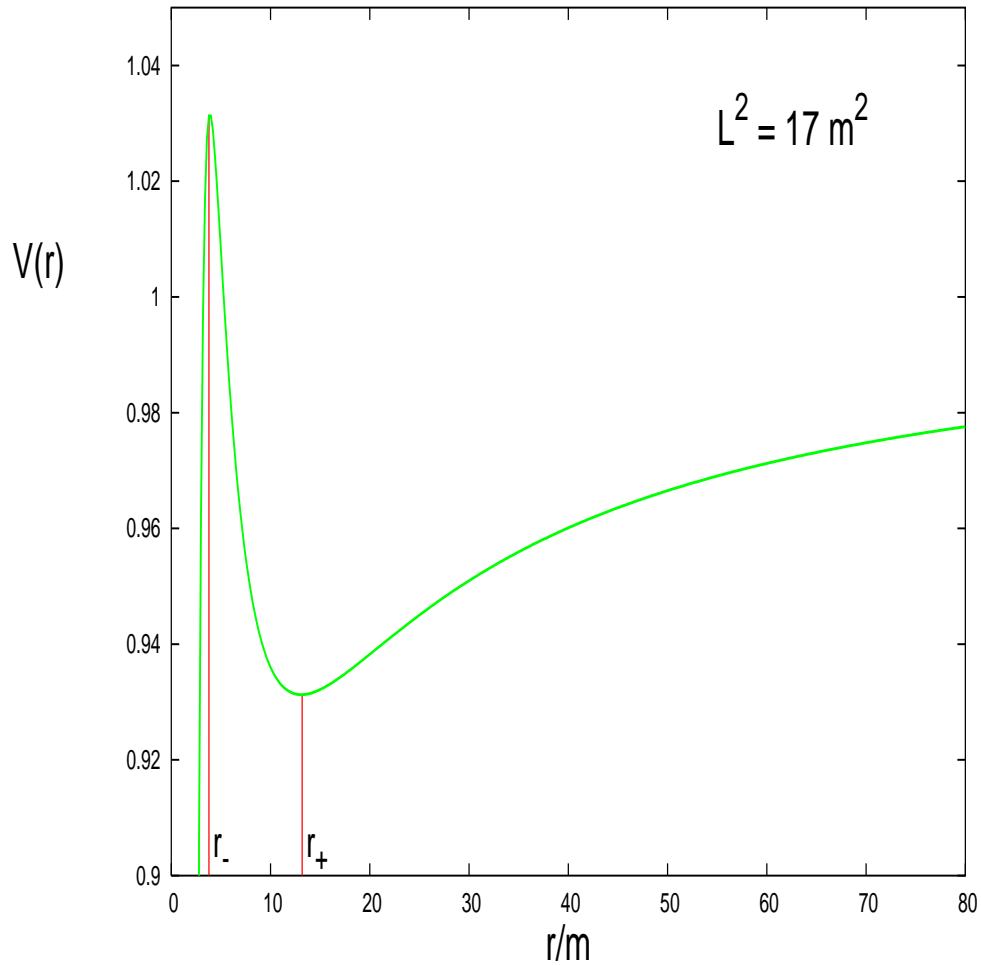

$V(r)$  has a maximum in  $r = r_-$  followed by a minimum in  $r = r_+$ ; thus, a particle with energy  $E^2 = V(r_-) \equiv V_{max}$  will move on an **unstable** circular orbit at  $r = r_-$ , whereas if  $E^2 = V(r_+) \equiv V_{min}$  it will move on a **stable** circular orbit at  $r = r_+$ . (See the discussion for  $\mathbf{E}^2 = \mathbf{V}_{max}$  in section 11.3 )

Depending on the value of  $L$  the maximum of the potential can be greater or smaller than 1, i.e.

- a)  $L^2 > 16m^2$      $V_{max} > 1$ ,
- b)  $12m^2 < L^2 < 16m^2$      $V_{max} < 1$ .

Case **b)** is shown in the following figure

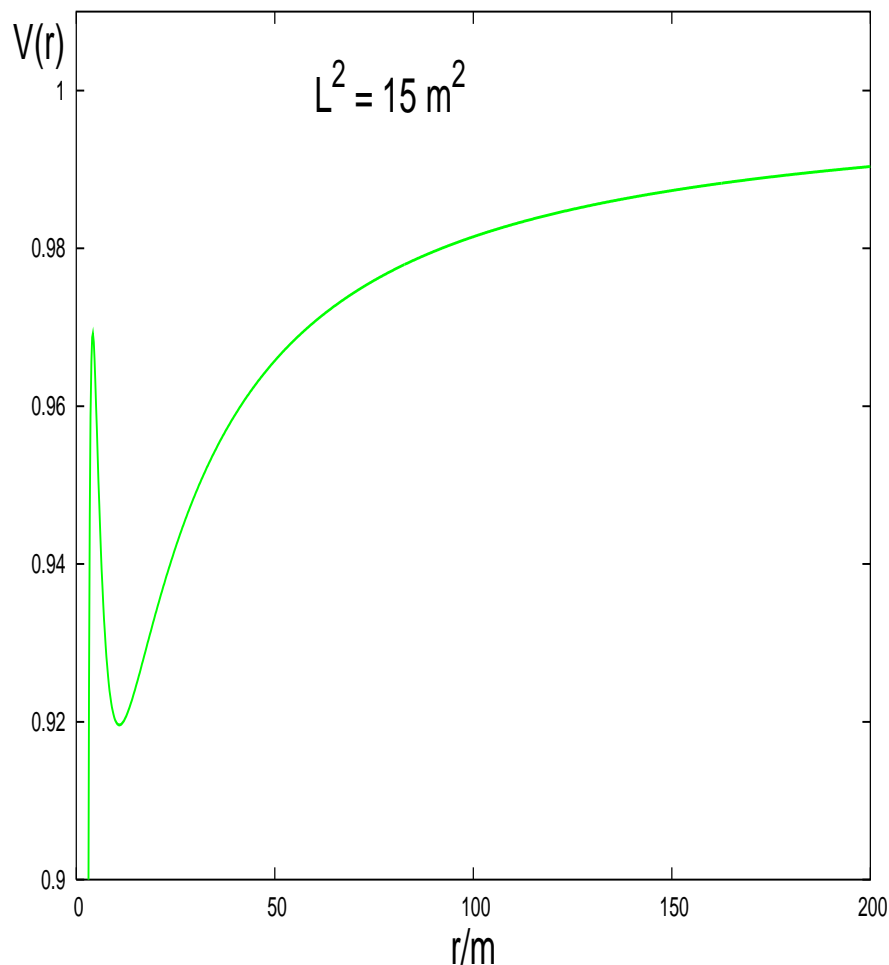

Therefore:

in case **a)** a particle with  $V_{min} < E^2 < 1$  will move on an **ellipse**, if  $1 < E^2 < V_{max}$  and  $\dot{r} \leq 0$  it will approach the black hole, reach a turning point  $r_0$  where  $E^2 = V(r_p)$  and  $\dot{r} = 0$  then, since it cannot penetrate the barrier, it will invert its radial velocity and escape free at infinity. (See the discussion for  $E^2 < V_{max}$  in section 11.3 )

Conversely, if  $E^2 > V_{max}$  and  $\dot{r} \leq 0$  it will fall in the black hole.

In case **b)** a particle with  $V_{min} < E^2 < V_{max}$  will move on an elliptic orbit, whereas if  $E^2 > 1$  and  $\dot{r} \leq 0$ , since  $\dot{r}^2 = E^2 - V(r)$ , it will approach the black hole horizon with increasing velocity and finally fall in.

From the expression of  $r_{\pm}$  given in eq. (11.59) we see that if  $L^2 = 12m^2$  the two roots coincide and

$$r_- = r_+ = 6m.$$

This means that there cannot exist stable circular orbits with radius smaller than  $6m$ . In

addition, when  $L \rightarrow \infty$ ,  $r_+ \rightarrow \infty$  and

$$r_- = \frac{L^2}{2m} \left( 1 - \sqrt{1 - \frac{12m^2}{L^2}} \right) \rightarrow \frac{L^2}{2m} \left( 1 - \left( 1 - \frac{6m^2}{L^2} + \dots \right) \right) = 3m + O\left(\frac{m}{L^2}\right)$$

therefore unstable circular orbits exist only between

$$3m < r_- < 6m.$$

### 11.4.1 The radial fall of a massive particle

Let us consider a massive particle falling radially into a Schwarzschild black hole.

In this case  $d\phi/d\tau = 0$ , therefore  $L = 0$ ; moreover, since the particle is moving inwards,  $\dot{r} < 0$ . In this case equations (11.56) become

$$\frac{dt}{d\tau} = \frac{E}{1 - \frac{2m}{r}} \quad \frac{dr}{d\tau} = -\sqrt{E^2 - 1 + \frac{2m}{r}} \quad (11.60)$$

$$\frac{d\theta}{d\tau} = 0 \quad \frac{d\phi}{d\tau} = 0. \quad (11.61)$$

If we consider a particle which is at rest at infinity, i.e. such that

$$\lim_{r \rightarrow \infty} \frac{dr}{d\tau} = 0 \quad (11.62)$$

from (11.60) it follows that

$$E = 1 \quad (11.63)$$

and the equations for  $t$  and  $r$  reduce to

$$\frac{dt}{d\tau} = \frac{1}{1 - \frac{2m}{r}} \quad (11.64)$$

$$\frac{dr}{d\tau} = -\sqrt{\frac{2m}{r}}. \quad (11.65)$$

We shall now integrate these equations.

- Putting  $r_0 \equiv r(\tau = 0)$ , eq. (11.65) gives

$$\begin{aligned} \tau(r) &= -\int_{r_0}^r dr' \sqrt{\frac{r'}{2m}} = -\frac{1}{\sqrt{2m}} \int_{r_0}^r dr' (r')^{1/2} \\ &= \frac{2}{3} \frac{1}{\sqrt{2m}} \left( r_0^{3/2} - r^{3/2} \right); \end{aligned} \quad (11.66)$$

the radial trajectory  $r(\tau)$  is the inverse function of  $\tau(r)$ ; it is not known analytically, but it can be found numerically.

- To find  $t(r)$ , we combine equations (11.64) and (11.65):

$$\frac{dt}{dr} = -\frac{1}{1 - \frac{2m}{r}} \sqrt{\frac{r}{2m}}. \quad (11.67)$$

If we set  $t = 0$  when  $\tau = 0$  we find

$$t(r) = \int_0^t dt' = - \int_{r_0}^r \frac{1}{1 - \frac{2m}{r'}} \sqrt{\frac{r'}{2m}}; \quad (11.68)$$

by solving the integral in (11.68) we get (we omit the explicit computation and give only the result):

$$\begin{aligned} t(r) = & \frac{2}{3} \frac{1}{\sqrt{2m}} \left[ r_0^{2/3} - r^{2/3} + 6mr_0^{1/2} - 6mr^{1/2} \right] \\ & + 2m \ln \left[ \frac{\sqrt{r_0} - \sqrt{2m}}{\sqrt{r_0} + \sqrt{2m}} \frac{\sqrt{r} + \sqrt{2m}}{\sqrt{r} - \sqrt{2m}} \right]; \end{aligned} \quad (11.69)$$

$r(t)$  is the inverse function of  $t(r)$  and, as  $r(\tau)$ , is not known analytically.

In figure 11.2 we plot  $t(r)$  and  $\tau(r)$ . Assuming for simplicity  $r_0 \gg 2m$ , the behaviour of  $t(r)$

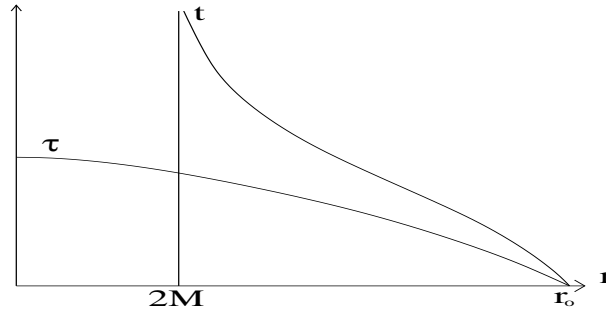

Figure 11.2:

for  $r \rightarrow 2m$  and  $r \rightarrow \infty$  is:

- for  $r \simeq 2m$

$$t \simeq -2m \ln(\sqrt{r} - \sqrt{2m}) + \text{const.} \rightarrow \infty \quad (11.70)$$

- for  $r \rightarrow \infty$

$$t \simeq \frac{2}{3} \frac{1}{\sqrt{2m}} (r_0^{3/2} - r^{3/2}) \equiv \tau. \quad (11.71)$$

From eq. (11.70) we see that for  $r \rightarrow 2m$ ,  $t(r)$  diverges<sup>2</sup> while eq. (11.66) shows that  $\tau(r)$  is *regular* at  $r = 2m$ . The inverse functions  $r(\tau)$  and  $r(t)$  are plotted in figure 11.3. From figure

<sup>2</sup>We also note that even if the coordinate frame  $\{t, r, \theta, \phi\}$  is defined in  $\{0 < r < 2m\} \cup \{r > 2m\}$ , namely, outside and inside the horizon, these coordinates are really meaningful (i.e., they are useful to describe physical processes) only for  $r > 2m$ , i.e. outside the horizon.

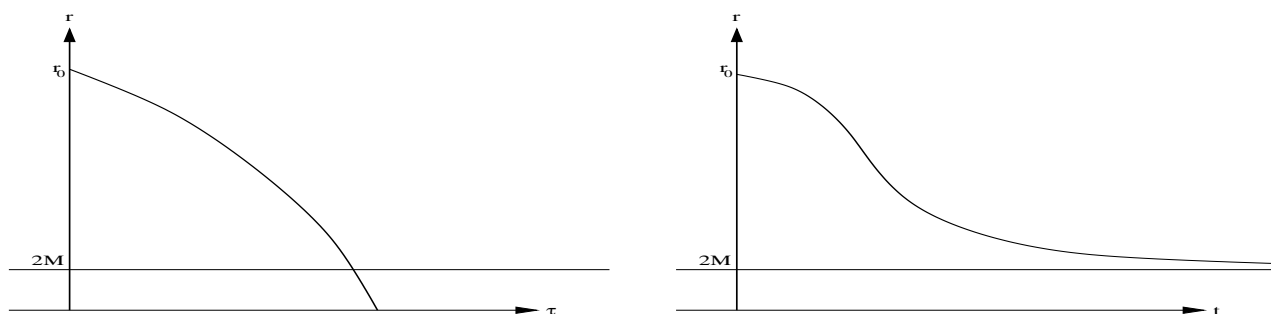

Figure 11.3:

11.3 we also see that  $r(\tau)$ , which is the radial trajectory as a function of the *proper time*, i.e. as seen by an observer moving with the particle, for  $r = 2m$  has a regular behaviour: this observer does not feel anything strange in crossing the horizon, and after crossing it he reaches the singularity in a finite amount of proper time.

The function  $r(t)$ , instead, approaches  $r = 2m$  only asymptotically. In order to understand what is the meaning of this behaviour, let us consider a spaceship which, while falling radially into the black hole, sends an SOS in the form of a sequence of equally spaced electromagnetic pulses; these signals are received by an observer at radial infinity, located at  $r = r^{obs}$ . The SOS travels along null geodesics  $t = t(\lambda)$ ,  $r = r(\lambda)$ , with  $\theta, \phi$  constants, and where  $\lambda$  is the affine parameter along the geodesic. The process is described in Figure 11.4.1. As shown in section 10.7,

$$g_{\mu\nu} \frac{dx^\mu}{d\lambda} \frac{dx^\nu}{d\lambda} = 0 = - \left(1 - \frac{2m}{r}\right) \left(\frac{dt}{d\lambda}\right)^2 + \left(1 - \frac{2m}{r}\right)^{-1} \left(\frac{dr}{d\lambda}\right)^2, \quad (11.72)$$

hence

$$\left(\frac{dr}{dt}\right)^2 = \left(1 - \frac{2m}{r}\right)^2 \rightarrow \frac{dt}{dr} = \pm \frac{r}{r - 2m}, \quad (11.73)$$

the solution of which is

$$t = \pm r_* + const \quad (11.74)$$

where  $r_*$  is the *tortoise coordinate* already introduced in eq. (10.74)

$$r_* \equiv r + 2m \log \left( \frac{r}{2m} - 1 \right), \quad (11.75)$$

so that

$$\frac{dr}{dr_*} = 1 - \frac{2m}{r}. \quad (11.76)$$

As in (10.75) we define the outgoing coordinate

$$u \equiv t - r_* \quad (11.77)$$

so that a given outgoing null geodesic is characterized by a constant value of  $u$ .

Let us consider two electromagnetic pulses sent from the spaceship as it approaches the horizon, the first at  $\tau = \tau_1$ , the second at  $\tau = \tau_2$  (see figure 11.4.1). The two pulses correspond to  $u = u_1$  and  $u = u_2$ , respectively. The observer at infinity detects the pulses at

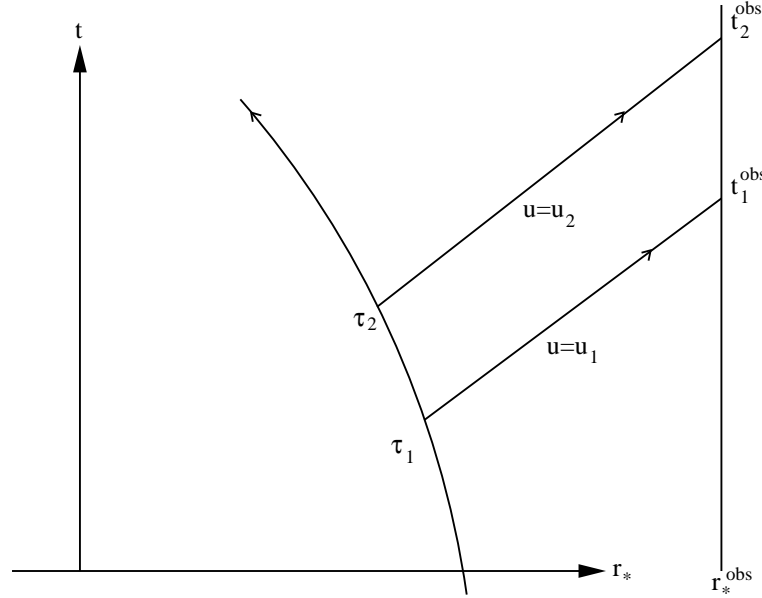

Figure 11.4: A spaceship radially falling into the black hole sends electromagnetic signals to a distant observer

two values of its own proper time, which coincides with the coordinate time, i.e. at  $t = t_1^{obs}$  and  $t = t_2^{obs}$ . Thus, while the man on the spaceship measures a proper time interval between the pulses

$$\Delta\tau = \tau_2 - \tau_1, \quad (11.78)$$

the observer at infinity measures a corresponding coordinate time interval

$$\Delta t^{obs} = t_2^{obs} - t_1^{obs} = (u_2 + r_*^{obs}) - (u_1 + r_*^{obs}) = u_2 - u_1. \quad (11.79)$$

Therefore, assuming that the pulses are emitted at very short time intervals, we can write

$$\frac{\Delta t^{obs}}{\Delta\tau} = \frac{\Delta u}{\Delta\tau} \simeq \frac{du}{d\tau} \quad (11.80)$$

where the derivative is taken along the spaceship worldline (the red curve in figure 11.4.1). Using equations (11.64), (11.65), (11.76) and (11.77), we find

$$\begin{aligned} \frac{\Delta t^{obs}}{\Delta\tau} &= \frac{du}{d\tau} = \frac{dt}{d\tau} - \frac{dr_*}{d\tau} = \frac{dt}{d\tau} - \frac{dr_*}{dr} \frac{dr}{d\tau} \\ &= \frac{1}{1 - \frac{2m}{r}} \left( 1 + \sqrt{\frac{2m}{r}} \right). \end{aligned} \quad (11.81)$$

This equation shows that as  $r \rightarrow 2m$ ,  $\frac{\Delta t^{obs}}{\Delta \tau} \rightarrow \infty$ , which means that the time interval between pulses as detected by the observer at infinity increases, and finally diverges, as the spaceship approaches the horizon.

It is interesting to note that the right hand side of eq. (11.81) has two terms: the first is the square of the gravitational redshift, the second is a Doppler contribution due to the fact that, while sending the pulses, the ship is moving away from the observer.

### 11.4.2 The motion of a planet around the Sun

Let us now use the geodesic equations (11.56) to study the motion of a planet around the Sun. We can consider the limit

$$\frac{m}{r} \ll 1, \quad (11.82)$$

indeed, if we consider Mercury, which is the closest planet to the Sun, since the Mercury-Sun distance is  $r \sim 5.8 \cdot 10^7$  km, we find

$$\frac{GM_{\odot}}{rc^2} = \frac{1.4768}{5.8 \cdot 10^7} \sim 2.510^{-8}.$$

In what follows, we shall indicate with a prime differentiation with respect to  $\phi$ , and use the variable  $u \equiv \frac{1}{r}$ , as we did in Section 11.3.1. In terms of  $u$ , the equation for  $\dot{\phi}$  becomes

$$\dot{\phi} = Lu^2,$$

and

$$\dot{r} = r'\dot{\phi} = -\frac{1}{u^2}u'\dot{\phi} = -Lu'.$$

By substituting in eq. (11.56), it becomes

$$L^2(u')^2 + 1 - 2mu + u^2L^2 - 2mL^2u^3 = E,$$

and differentiating with respect to  $\phi$ ,

$$2L^2u''u' - 2mu' + 2uu'L^2 - 6mL^2u'u^2 = 0.$$

Dividing by  $2L^2u'$ , we find the equation for  $u$

$$u'' + u - \frac{m}{L^2} - 3mu^2 = 0. \quad (11.83)$$

#### The Newtonian equation

The Newtonian equation which corresponds to the third eq. (11.56) is derived from the energy conservation law

$$\frac{1}{2}m_p(\dot{r})^2 - \frac{m_p m}{r} + \frac{1}{2}m_p r^2(\dot{\phi})^2 = const$$

where  $m_p$  is the particle mass and we have set  $G = 1$ . Dividing by  $m_p/2$  it becomes

$$(\dot{r})^2 - \frac{2m}{r} + \frac{L^2}{r^2} = \text{const.} \quad (11.84)$$

Expressing (11.84) in  $u$  and deriving with respect to  $\phi$ , one finds

$$2L^2 u'' u' - 2m u' + 2u u' L^2 = 0$$

which becomes

$$u'' + u - \frac{m}{L^2} = 0. \quad (11.85)$$

Equation (11.85) differs from equation (11.83) only by the term  $3mu^2$ , which is smaller than, say,  $u$  by a factor

$$3mu = \frac{3m}{r} \ll 1.$$

Let us solve equation (11.85). It can be rewritten as

$$\left(u - \frac{m}{L^2}\right)'' + \left(u - \frac{m}{L^2}\right) = 0$$

and the solution is

$$u = \frac{m}{L^2} (1 + e \cos(\phi - \phi_0)),$$

where  $\phi_0$  and  $e \in (0, 1)$  are integration constants. In terms of  $r$ ,

$$r = \frac{L^2}{m} \frac{1}{1 + e \cos(\phi - \phi_0)} = a \frac{1 - e^2}{1 + e \cos(\phi - \phi_0)}$$

which describes an ellipse with eccentricity  $e$  and semi-major axis given by

$$a = \frac{L^2}{m(1 - e^2)}. \quad (11.86)$$

The perihelion is at  $\phi = \phi_0$  and  $r = a(1 - e^2)$ . It is worth noting that, if  $e$  is not too close to 1,

$$\frac{m^2}{L^2} \simeq \frac{m}{a} \ll 1.$$

### The relativistic case

In order to solve equation (11.83)

$$u'' + u - \frac{m}{L^2} - 3mu^2 = 0 \quad (11.87)$$

we adopt an iterative procedure, as we did in Section 11.3.1. We search for a solution in the form

$$u = u^{(0)} + u^{(1)}$$

where  $u^{(0)}$  is the solution of the newtonian equation

$$u^{(0)} = \frac{m}{L^2} (1 + e \cos(\phi - \phi_0)) ,$$

and

$$u^{(1)} \ll u^{(0)} .$$

Since, as we have seen, the term  $3mu^2$  is small, we can approximate equation (11.87) to

$$u'' + u - \frac{m}{L^2} - 3m(u^{(0)})^2 = 0 . \quad (11.88)$$

Consequently,

$$u'' + u - \frac{m}{L^2} = 3\frac{m^3}{L^4} + 6e\frac{m^3}{L^4} \cos(\phi - \phi_0) + 3e^2\frac{m^3}{L^4} \cos^2(\phi - \phi_0) . \quad (11.89)$$

This is the equation of an harmonic oscillator with three forcing terms on the right hand side. They are very small, because

$$\frac{m^3}{L^4} \ll \frac{m}{L^2} ,$$

so the first and the third term contribute to the solution as small amplitude perturbations. The second term,

$$6e\frac{m^3}{L^4} \cos(\phi - \phi_0) ,$$

is in resonance with the free oscillations of the harmonic oscillator, therefore, even if its amplitude is small, it determines a secular perturbation of the planet motion, which, after a long time, becomes relevant. For this reason, we will neglect the terms  $3\frac{m^3}{L^4}$  and  $3e^2\frac{m^3}{L^4} \cos^2(\phi - \phi_0)$ , and look for the solution of the resulting equation

$$u'' + u - \frac{m}{L^2} = 6e\frac{m^3}{L^4} \cos(\phi - \phi_0) . \quad (11.90)$$

The solution, in the form  $u = u^{(0)} + u^{(1)}$ , is

$$u^{(0)} = \frac{m}{L^2} (1 + e \cos(\phi - \phi_0))$$

$$u^{(1)} = 3e\frac{m^3}{L^4} \phi \sin(\phi - \phi_0) .$$

In fact, by substituting in (11.90),

$$\begin{aligned} & u^{(0)''} + u^{(0)} - \frac{m}{L^2} + u^{(1)''} + u^{(1)} - 6e\frac{m^3}{L^4} \cos(\phi - \phi_0) \\ = & u^{(1)''} + u^{(1)} - 6e\frac{m^3}{L^4} \cos(\phi - \phi_0) \\ = & -3e\frac{m^3}{L^4} \phi \sin(\phi - \phi_0) + 6e\frac{m^3}{L^4} \cos(\phi - \phi_0) + 3e\frac{m^3}{L^4} \phi \sin(\phi - \phi_0) - 6e\frac{m^3}{L^4} \cos(\phi - \phi_0) \\ = & 0 . \end{aligned}$$

Thus,

$$u = \frac{m}{L^2} \left[ 1 + e \left( \cos(\phi - \phi_0) + 3\frac{m^2}{L^2} \phi \sin(\phi - \phi_0) \right) \right].$$

At first order in  $m^2/L^2$ ,

$$\begin{aligned} \cos\left(\frac{3m^2}{L^2}\phi\right) &\simeq 1 \\ \sin\left(\frac{3m^2}{L^2}\phi\right) &\simeq \frac{3m^2}{L^2}\phi \end{aligned}$$

therefore we can write

$$u \sim \frac{m}{L^2} \left[ 1 + e \cos\left(\phi - \phi_0 - 3\frac{m^2}{L^2}\phi\right) \right]. \quad (11.91)$$

A comparison with the corresponding newtonian equation shows that the term  $\frac{3m^2}{L^2}\phi$  determines a secular precession of the perihelion. The argument of the sinusoidal function in eq. (11.91) changes by  $2\pi$  when  $\phi$  changes by

$$\Delta\phi = \frac{2\pi}{1 - \frac{3m^2}{L^2}} \simeq 2\pi \left( 1 + \frac{3m^2}{L^2} \right).$$

Thus, in a period, the perihelion is shifted by

$$\Delta\phi_P = \frac{6\pi m^2}{L^2} = \frac{6\pi m}{a(1 - e^2)} \quad (11.92)$$

where we have used eq. (11.86).

For example, in the case of Mercury equation (11.92) gives a precession of 42.98 arcsec/century. The observed precession is of  $43.1 \pm 0.1$  arcsec/century.

# Chapter 12

## The Geodesic deviation

The Principle of equivalence establishes that we can always choose a locally inertial frame where the affine connections vanish and the metric becomes that of a flat spacetime. Conversely, if the spacetime is flat we can always define a coordinate system which “simulates”, locally, the existence of any arbitrary gravitational field. In this frame we could measure the “simulated” gravitational force by studying the motion of a single particle, but these measurements would never allow us to know whether that force is simulated or real: this can be understood only by comparing the motion of close particles, i.e. by comparing the behaviour of close geodesics.

### 12.1 The equation of geodesic deviation

Consider two particles moving along the trajectories  $x^\mu(\tau)$  and  $x^\mu(\tau) + \delta x^\mu(\tau)$ , where  $\delta x^\mu$  is the vector of separation between the two close geodesics, and  $\tau$  is an **affine parameter**. This is equivalent to say: consider a two-parameter family of geodesics  $x^\mu(\tau, p)$ , where the parameter  $p$  labels different geodesics

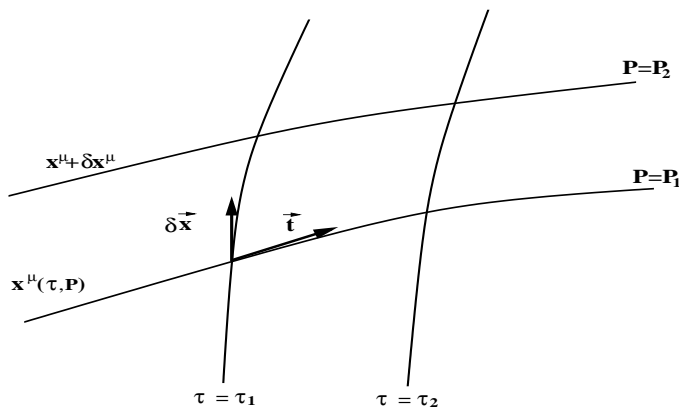

Be

$$t^\alpha = \frac{\partial x^\alpha}{\partial \tau} \tag{12.1}$$

the tangent vector to the geodesic line, and be

$$\delta x^\alpha = \frac{\partial x^\alpha}{\partial p}. \quad (12.2)$$

Note that

$$\frac{\partial t^\alpha}{\partial p} = \frac{\partial \delta x^\alpha}{\partial \tau}. \quad (12.3)$$

We now compute the covariant derivative of the vector  $\vec{t}$  along the curve  $\tau = \text{const}$  whose tangent vector is  $\delta x^\mu$ , i.e.  $\nabla_{\delta \vec{x}} \vec{t} = \frac{d\vec{t}}{dp} = \frac{\partial \vec{t}}{\partial x^\mu} \frac{dx^\mu}{dp}$ . The components of this vector are

$$\left(\nabla_{\delta \vec{x}} \vec{t}\right)^\alpha = \frac{\partial x^\mu}{\partial p} \left[ \frac{\partial t^\alpha}{\partial x^\mu} + \Gamma^\alpha_{\mu\nu} t^\nu \right] = \frac{\partial t^\alpha}{\partial p} + \Gamma^\alpha_{\mu\nu} t^\nu \delta x^\mu. \quad (12.4)$$

The covariant derivative of the vector  $\delta x$  along the curve  $p = \text{const}$  i.e. along the geodesic, similarly has components

$$\left(\nabla_{\vec{t}} \delta \vec{x}\right)^\alpha = \left(\frac{d\delta \vec{x}}{d\tau}\right)^\alpha = t^\mu \delta x^\alpha{}_{;\mu} = \frac{\partial \delta x^\alpha}{\partial \tau} + \Gamma^\alpha_{\mu\nu} \delta x^\nu t^\mu. \quad (12.5)$$

From eq. (12.3) and from the symmetry of  $\Gamma^\alpha_{\mu\nu}$  in the lower indices it follows that

$$\nabla_{\vec{t}} \delta \vec{x} = \nabla_{\delta \vec{x}} \vec{t}. \quad (12.6)$$

The quantities  $\left(\nabla_{\vec{t}} \delta \vec{x}\right)^\alpha$  or  $\left(\nabla_{\delta \vec{x}} \vec{t}\right)^\alpha$  involve only the affine connections, and therefore they do not give significant information on the gravitational field. We then compute the second covariant derivative of the vector  $\delta \vec{x}$  along the curve  $p = \text{const}$ , i.e.  $\nabla_{\vec{t}} \left(\nabla_{\vec{t}} \delta \vec{x}\right)$ . From eq. (12.6) it follows that

$$\nabla_{\vec{t}} \left(\nabla_{\vec{t}} \delta \vec{x}\right) = \nabla_{\vec{t}} \left(\nabla_{\delta \vec{x}} \vec{t}\right). \quad (12.7)$$

This equation can be rewritten as

$$\frac{d^2 \delta x^\alpha}{d\tau^2} = \left(\nabla_{\vec{t}} \left(\nabla_{\delta \vec{x}} \vec{t}\right)\right)^\alpha. \quad (12.8)$$

In order to compute the right-hand side of eq. (12.8), let us consider the commutator

$$\left[\nabla_{\vec{t}} \left(\nabla_{\delta \vec{x}} \vec{t}\right)\right] = \nabla_{\vec{t}} \left(\nabla_{\delta \vec{x}} \vec{t}\right) - \nabla_{\delta \vec{x}} \left(\nabla_{\vec{t}} \vec{t}\right), \quad (12.9)$$

whose components are

$$\begin{aligned} \left[\nabla_{\vec{t}} \left(\nabla_{\delta \vec{x}} \vec{t}\right)\right]^\alpha &= t^\mu (\delta x^\nu t^\alpha{}_{;\nu})_{;\mu} - \delta x^\mu (t^\nu t^\alpha{}_{;\nu})_{;\mu} \\ &= t^\mu \delta x^\nu{}_{;\mu} t^\alpha{}_{;\nu} + t^\mu \delta x^\nu t^\alpha{}_{;\nu;\mu} - \delta x^\mu t^\nu{}_{;\mu} t^\alpha{}_{;\nu} - \delta x^\mu t^\nu t^\alpha{}_{;\nu;\mu} \\ &= (t^\mu \delta x^\nu{}_{;\mu} - \delta x^\mu t^\nu{}_{;\mu}) t^\alpha{}_{;\nu} + (t^\alpha{}_{;\nu;\mu} - t^\alpha{}_{;\mu;\nu}) t^\mu \delta x^\nu. \end{aligned} \quad (12.10)$$

From eq. (12.6) we find that

$$t^\mu \delta x^\nu{}_{;\mu} = \delta x^\mu t^\nu{}_{;\mu},$$

and eq. (12.11) becomes

$$\left[ \nabla_{\vec{t}} \left( \nabla_{\vec{\delta x}} \vec{t} \right) \right]^\alpha = (t^\alpha{}_{;\nu;\mu} - t^\alpha{}_{;\mu;\nu}) \delta x^\mu t^\nu. \quad (12.11)$$

We now remind that, according to eq. (6.40), the commutator of covariant derivatives is

$$(t^\alpha{}_{;\nu;\mu} - t^\alpha{}_{;\mu;\nu}) = R^\alpha{}_{\beta\nu\mu} t^\beta, \quad (12.12)$$

therefore eq. (12.11) becomes

$$\left[ \nabla_{\vec{t}} \left( \nabla_{\vec{\delta x}} \vec{t} \right) \right]^\alpha = R^\alpha{}_{\beta\nu\mu} t^\beta \delta x^\mu t^\nu. \quad (12.13)$$

Moreover, since  $t^\mu$  is the geodesic tangent vector, when it is parallel-transported along the geodesic it gives (see chapter 6.2)

$$\nabla_{\vec{t}} \vec{t} = 0; \quad (12.14)$$

as a consequence  $\nabla_{\vec{\delta x}} \left( \nabla_{\vec{t}} \vec{t} \right) = 0$  and the commutator (12.9) becomes

$$\left[ \nabla_{\vec{t}} \left( \nabla_{\vec{\delta x}} \vec{t} \right) \right] = \nabla_{\vec{t}} \left( \nabla_{\vec{\delta x}} \vec{t} \right). \quad (12.15)$$

Therefore eq. (12.13) can be rewritten as

$$\left( \nabla_{\vec{t}} \left( \nabla_{\vec{\delta x}} \vec{t} \right) \right)^\alpha = R^\alpha{}_{\beta\nu\mu} t^\beta \delta x^\mu t^\nu. \quad (12.16)$$

By direct substitution of this expression in eq. (12.8) we finally find

$$\frac{d^2 \delta x^\alpha}{d\tau^2} = R^\alpha{}_{\beta\nu\mu} t^\beta t^\nu \delta x^\mu. \quad (12.17)$$

This is the equation of **geodesic deviation**, which shows that the relative acceleration of nearby particles moving along geodesics depends on the curvature tensor. Since the Riemann tensor is zero if and only if the gravitational field is either zero or constant and uniform, the equation of the geodesic deviation really contains the information on the gravitational field in a given spacetime.

# Chapter 13

## Gravitational Waves

One of the most interesting predictions of the theory of General Relativity is the existence of gravitational waves. The idea that a perturbation of the gravitational field should propagate as a wave is, in some sense, intuitive. For example electromagnetic waves were introduced when the Coulomb theory of electrostatics was replaced by the theory of electrodynamics, and it was shown that they transport through space the information about the evolution of charged systems. In a similar way when a mass-energy distribution changes in time, the information about this change should propagate in the form of waves. However, gravitational waves have a distinctive feature: due to the twofold nature of  $g_{\mu\nu}$ , which is the metric tensor and the gravitational potential, gravitational waves are **metric waves**. Thus when they propagate the geometry, and consequently the distance between points, change in time.

Gravitational waves can be studied by following two different approaches, one based on perturbative methods, the second on the solution of the non linear Einstein equations.

### *The perturbative approach*

Be  $g_{\mu\nu}^0$  a known exact solution of Einstein's equations; it can be, for instance, the metric of flat spacetime  $\eta_{\mu\nu}$ , or the metric generated by a Schwarzschild black hole. Let us consider a small perturbation of  $g_{\mu\nu}^0$  caused by some source described by a stress-energy tensor  $T_{pert}^{\mu\nu}$ . We shall write the metric tensor of the perturbed spacetime,  $g_{\mu\nu}$ , as follows

$$g_{\mu\nu} = g_{\mu\nu}^0 + h_{\mu\nu}, \quad (13.1)$$

where  $h_{\mu\nu}$  is the small perturbation

$$|h_{\mu\nu}| \ll |g_{\mu\nu}^0|.$$

It is clear that this assumption is ambiguous, because we should specify in which reference frame this is true; however we shall assume that this frame does exist.

The inverse metric can be written as

$$g^{\mu\nu} = g^{0\mu\nu} - h^{\mu\nu} + O(h^2), \quad (13.2)$$

where the indices of  $h^{\mu\nu}$  have been raised with the *unperturbed* metric

$$h^{\mu\nu} \equiv g^{0\mu\alpha} g^{0\nu\beta} h_{\alpha\beta}. \quad (13.3)$$

Indeed, with this definition,

$$(g^{0\mu\nu} - h^{\mu\nu})(g_{\nu\alpha}^0 + h_{\nu\alpha}) = \delta_{\alpha}^{\mu} + O(h^2). \quad (13.4)$$

In order to find the equations that describe  $h_{\mu\nu}$ , we shall write Einstein's equations for the metric (13.1) in the form

$$R_{\mu\nu} = \frac{8\pi G}{c^4} \left( T_{\mu\nu} - \frac{1}{2} g_{\mu\nu} T_{\lambda}^{\lambda} \right), \quad (13.5)$$

where  $T_{\mu\nu}$  is the sum of two terms, one associate to the source that generates the background geometry  $g_{\mu\nu}^0$ , say  $T_{\mu\nu}^0$ , and one associate to the source of the perturbation  $T_{\mu\nu}^{pert}$ . We remind that the Ricci tensor  $R_{\mu\nu}$  is

$$R_{\mu\nu} = \frac{\partial}{\partial x^{\alpha}} \Gamma^{\alpha}_{\mu\nu} - \frac{\partial}{\partial x^{\nu}} \Gamma^{\alpha}_{\mu\alpha} + \Gamma^{\alpha}_{\sigma\alpha} \Gamma^{\sigma}_{\mu\nu} - \Gamma^{\alpha}_{\sigma\nu} \Gamma^{\sigma}_{\mu\alpha}, \quad (13.6)$$

and that the affine connections  $\Gamma^{\gamma}_{\beta\mu}$  are

$$\Gamma^{\gamma}_{\beta\mu} = \frac{1}{2} g^{\alpha\gamma} \left[ \frac{\partial}{\partial x^{\mu}} g_{\alpha\beta} + \frac{\partial}{\partial x^{\beta}} g_{\alpha\mu} - \frac{\partial}{\partial x^{\alpha}} g_{\beta\mu} \right]. \quad (13.7)$$

The  $\Gamma^{\gamma}_{\beta\mu}$  computed for the perturbed metric (13.1) are

$$\begin{aligned} \Gamma^{\gamma}_{\beta\mu}(g_{\mu\nu}) &= \frac{1}{2} [g^{0\alpha\gamma} - h^{\alpha\gamma}] \left[ \left( \frac{\partial}{\partial x^{\mu}} g_{\alpha\beta}^0 + \frac{\partial}{\partial x^{\beta}} g_{\alpha\mu}^0 - \frac{\partial}{\partial x^{\alpha}} g_{\beta\mu}^0 \right) + \left( \frac{\partial}{\partial x^{\mu}} h_{\alpha\beta} + \frac{\partial}{\partial x^{\beta}} h_{\alpha\mu} - \frac{\partial}{\partial x^{\alpha}} h_{\beta\mu} \right) \right] \\ &= \frac{1}{2} g^{0\alpha\gamma} \left[ \frac{\partial}{\partial x^{\mu}} g_{\alpha\beta}^0 + \frac{\partial}{\partial x^{\beta}} g_{\alpha\mu}^0 - \frac{\partial}{\partial x^{\alpha}} g_{\beta\mu}^0 \right] + \frac{1}{2} g^{0\alpha\gamma} \left[ \frac{\partial}{\partial x^{\mu}} h_{\alpha\beta} + \frac{\partial}{\partial x^{\beta}} h_{\alpha\mu} - \frac{\partial}{\partial x^{\alpha}} h_{\beta\mu} \right] \\ &\quad - \frac{1}{2} h^{\alpha\gamma} \left[ \frac{\partial}{\partial x^{\mu}} g_{\alpha\beta}^0 + \frac{\partial}{\partial x^{\beta}} g_{\alpha\mu}^0 - \frac{\partial}{\partial x^{\alpha}} g_{\beta\mu}^0 \right] + O(h^2) \\ &= \Gamma^{\gamma}_{\beta\mu}(g^0) + \Gamma^{\gamma}_{\beta\mu}(h) + O(h^2), \end{aligned} \quad (13.8)$$

where  $\Gamma^{\gamma}_{\beta\mu}(h)$  are the terms that are first order in  $h_{\mu\nu}$

$$\Gamma^{\gamma}_{\beta\mu}(h) = \frac{1}{2} g^{0\alpha\gamma} \left[ \frac{\partial}{\partial x^{\mu}} h_{\alpha\beta} + \frac{\partial}{\partial x^{\beta}} h_{\alpha\mu} - \frac{\partial}{\partial x^{\alpha}} h_{\beta\mu} \right] - \frac{1}{2} h^{\alpha\gamma} \left[ \frac{\partial}{\partial x^{\mu}} g_{\alpha\beta}^0 + \frac{\partial}{\partial x^{\beta}} g_{\alpha\mu}^0 - \frac{\partial}{\partial x^{\alpha}} g_{\beta\mu}^0 \right]. \quad (13.9)$$

When we substitute these expressions of the  $\Gamma^{\gamma}_{\beta\mu}(g_{\mu\nu})$  in the Ricci tensor we get

$$\begin{aligned} R_{\mu\nu}(g_{\mu\nu}) &= R_{\mu\nu}(g^0) \\ &\quad + \frac{\partial}{\partial x^{\alpha}} \Gamma^{\alpha}_{\mu\nu}(h) - \frac{\partial}{\partial x^{\nu}} \Gamma^{\alpha}_{\mu\alpha}(h) \\ &\quad + \Gamma^{\alpha}_{\sigma\alpha}(g^0) \Gamma^{\sigma}_{\mu\nu}(h) + \Gamma^{\alpha}_{\sigma\alpha}(h) \Gamma^{\sigma}_{\mu\nu}(g^0) \\ &\quad - \Gamma^{\alpha}_{\sigma\nu}(g^0) \Gamma^{\sigma}_{\mu\alpha}(h) - \Gamma^{\alpha}_{\sigma\nu}(h) \Gamma^{\sigma}_{\mu\alpha}(g^0) + O(h^2) \\ &= \frac{8\pi G}{c^4} \left( T_{\mu\nu} - \frac{1}{2} g_{\mu\nu} T_{\lambda}^{\lambda} \right). \end{aligned} \quad (13.10)$$

Since  $g_{\mu\nu}^0$  is by assumption an exact solution of Einstein's equations in vacuum  $R_{\mu\nu}(g^0) = \frac{8\pi G}{c^4} (T_{\mu\nu}^0 - \frac{1}{2}g_{\mu\nu}^0 T_{\lambda}^0{}^\lambda)$ ; thus, if we retain only first order terms, the equations for the perturbations  $h_{\mu\nu}$  reduce to

$$\begin{aligned} & \frac{\partial}{\partial x^\alpha} \Gamma^\alpha{}_{\mu\nu}(h) - \frac{\partial}{\partial x^\nu} \Gamma^\alpha{}_{\mu\alpha}(h) \\ + & \Gamma^\alpha{}_{\sigma\alpha}(g^0) \Gamma^\sigma{}_{\mu\nu}(h) + \Gamma^\alpha{}_{\sigma\alpha}(h) \Gamma^\sigma{}_{\mu\nu}(g^0) \\ - & \Gamma^\alpha{}_{\sigma\nu}(g^0) \Gamma^\sigma{}_{\mu\alpha}(h) - \Gamma^\alpha{}_{\sigma\nu}(h) \Gamma^\sigma{}_{\mu\alpha}(g^0) = \frac{8\pi G}{c^4} \left( T_{\mu\nu}^{pert} - \frac{1}{2}g_{\mu\nu} T_{\lambda}^{pert}{}^\lambda \right). \end{aligned} \quad (13.11)$$

that are linear in  $h_{\mu\nu}$ ; their solution will describe the propagation of gravitational waves in the considered background.<sup>1</sup> This approximation works sufficiently well in a variety of physical situations because gravitational waves are very weak. This point will be better understood in the next chapter, when we will discuss the generation of gravitational waves.

### *The "exact" approach*

The second approach to the study of gravitational waves seeks for exact solutions of Einstein's equations which describe both the source and the emitted wave, but no solution of this kind has been found so far. Of course the non-linearity of the equations makes the problem very difficult; however, it may be noted that also in electrodynamics an exact solution of Maxwell's equations appropriate to describe the electromagnetic field produced by a current which decreases in an electric oscillator due to the emission of electromagnetic waves has never been found, although Maxwell's equations are linear.

Exact solutions of Einstein's equations describing gravitational waves can be found only if one imposes some particular symmetry as for example plane, spherical, or cylindrical symmetry. The interaction of plane waves can also be described in terms of exact solutions, and due to the non-linearity of the equations of gravity it is very different from the interaction of electromagnetic waves.

In the following we shall use the perturbative approach to show that a weak perturbation of the flat spacetime satisfies the wave equation.

## 13.1 A perturbation of the flat spacetime propagates as a wave

Let us consider the flat spacetime described by the metric tensor  $\eta_{\mu\nu}$  and a small perturbation  $h_{\mu\nu}$ , such that the resulting metric can be written as

$$g_{\mu\nu} = \eta_{\mu\nu} + h_{\mu\nu}, \quad |h_{\mu\nu}| \ll 1. \quad (13.12)$$

The affine connections (13.8) computed for the metric (13.12) give

$$\Gamma^\lambda{}_{\mu\nu} = \frac{1}{2}\eta^{\lambda\rho} \left[ \frac{\partial}{\partial x^\mu} h_{\rho\nu} + \frac{\partial}{\partial x^\nu} h_{\rho\mu} - \frac{\partial}{\partial x^\rho} h_{\mu\nu} \right] + O(h^2). \quad (13.13)$$

---

<sup>1</sup>Notice that the right-hand side of eq.(13.11) is a particular case of the Palatini identity.

Since the metric  $g_{\mu\nu}^0 \equiv \eta_{\mu\nu}$  is constant,  $\Gamma^\lambda_{\mu\nu}(g^0) = 0$  and the right-hand side of eq. (13.11) simply reduces to

$$\begin{aligned} \frac{\partial \Gamma^\alpha_{\mu\nu}}{\partial x^\alpha} - \frac{\partial \Gamma^\alpha_{\mu\alpha}}{\partial x^\nu} + O(h^2) \\ = \frac{1}{2} \left\{ -\square_F h_{\mu\nu} + \left[ \frac{\partial^2}{\partial x^\lambda \partial x^\mu} h^\lambda_\nu + \frac{\partial^2}{\partial x^\lambda \partial x^\nu} h^\lambda_\mu - \frac{\partial^2}{\partial x^\mu \partial x^\nu} h^\lambda_\lambda \right] \right\} + O(h^2). \end{aligned} \quad (13.14)$$

The operator  $\square_F$  is the D'Alembertian in flat spacetime

$$\square_F = \eta^{\alpha\beta} \frac{\partial}{\partial x^\alpha} \frac{\partial}{\partial x^\beta} = -\frac{\partial^2}{c^2 \partial t^2} + \nabla^2. \quad (13.15)$$

Einstein's equations (13.5) for  $h_{\mu\nu}$  finally become

$$\left\{ \square_F h_{\mu\nu} - \left[ \frac{\partial^2}{\partial x^\lambda \partial x^\mu} h^\lambda_\nu + \frac{\partial^2}{\partial x^\lambda \partial x^\nu} h^\lambda_\mu - \frac{\partial^2}{\partial x^\mu \partial x^\nu} h^\lambda_\lambda \right] \right\} = -\frac{16\pi G}{c^4} \left( T_{\mu\nu}^{\text{pert}} - \frac{1}{2} \eta_{\mu\nu} T_{\lambda}^{\text{pert } \lambda} \right). \quad (13.16)$$

As already discussed in chapter 8, the solution of eqs. (13.16) is not uniquely determined. If we make a coordinate transformation, the transformed metric tensor is still a solution: it describes the same physical situation seen from a different frame. But since we are working in the weak field limit, we are entitled to make only those transformations which preserve the condition  $|h_{\mu\nu}| \ll 1$ . If we make an infinitesimal coordinate transformation

$$x^{\mu'} = x^\mu + \epsilon^\mu(x), \quad (13.17)$$

where  $\epsilon^\mu$  is an arbitrary vector such that  $\frac{\partial \epsilon^\mu}{\partial x^\nu}$  is of the same order of  $h_{\mu\nu}$ , it is easy to check that since

$$g_{\mu\nu} = g_{\alpha'\beta'} \frac{\partial x^{\alpha'}}{\partial x^\mu} \frac{\partial x^{\beta'}}{\partial x^\nu} = (\eta_{\alpha\beta} + h_{\alpha\beta}) \frac{\partial x^{\alpha'}}{\partial x^\mu} \frac{\partial x^{\beta'}}{\partial x^\nu}, \quad (13.18)$$

then

$$h_{\mu\nu'} = h_{\mu\nu} - \frac{\partial \epsilon_\mu}{\partial x^\nu} - \frac{\partial \epsilon_\nu}{\partial x^\mu}. \quad (13.19)$$

In order to simplify eq. (13.16) it appears convenient to choose a coordinate system in which the harmonic gauge condition is satisfied, i.e.

$$g^{\mu\nu} \Gamma^\lambda_{\mu\nu} = 0. \quad (13.20)$$

Let us see why. This condition is equivalent to say that, up to terms that are first order in  $h_{\mu\nu}$ , the following equation is satisfied <sup>2</sup>

---

$$g^{\mu\nu} \Gamma^\lambda_{\mu\nu} = \frac{1}{2} \eta^{\mu\nu} \eta^{\lambda k} \left\{ \frac{\partial h_{k\mu}}{\partial x^\nu} + \frac{\partial h_{k\nu}}{\partial x^\mu} - \frac{\partial h_{\mu\nu}}{\partial x^k} \right\} = \frac{1}{2} \eta^{\lambda k} \{ h^\nu_{k,\nu} + h^\mu_{k,\mu} - h^\nu_{\nu,k} \}$$

Since the first two terms are equal we find

$$g^{\mu\nu} \Gamma^\lambda_{\mu\nu} = \eta^{\lambda k} \left\{ h^\mu_{k,\mu} - \frac{1}{2} h^\nu_{\nu,k} \right\}$$

q.e.d.

$$\frac{\partial}{\partial x^\mu} h^\mu{}_\nu = \frac{1}{2} \frac{\partial}{\partial x^\nu} h^\mu{}_\mu. \quad (13.21)$$

Using this condition the term in square brackets in eq. (13.16) vanishes, and Einstein's equations reduce to a simple wave equation supplemented by the condition (13.21)

$$\begin{cases} \square_F h_{\mu\nu} = -\frac{16\pi G}{c^4} \left( T_{\mu\nu} - \frac{1}{2} \eta_{\mu\nu} T^\lambda{}_\lambda \right) \\ \frac{\partial}{\partial x^\mu} h^\mu{}_\nu = \frac{1}{2} \frac{\partial}{\partial x^\nu} h^\mu{}_\mu, \end{cases} \quad (13.22)$$

(to hereafter, we omit the superscript 'pert' to indicate the stress-energy tensor associated to the source of the perturbation). If we introduce the tensor

$$\bar{h}_{\mu\nu} \equiv h_{\mu\nu} - \frac{1}{2} \eta_{\mu\nu} h^\lambda{}_\lambda, \quad (13.23)$$

eqs. (13.22) become

$$\begin{cases} \square_F \bar{h}_{\mu\nu} = -\frac{16\pi G}{c^4} T_{\mu\nu} \\ \frac{\partial}{\partial x^\mu} \bar{h}^\mu{}_\nu = 0, \end{cases} \quad (13.24)$$

and outside the source where  $T_{\mu\nu} = 0$

$$\begin{cases} \square_F \bar{h}_{\mu\nu} = 0 \\ \frac{\partial}{\partial x^\mu} \bar{h}^\mu{}_\nu = 0. \end{cases} \quad (13.25)$$

**Thus, we have shown that a perturbation of a flat spacetime propagates as a wave travelling at the speed of light, and that Einstein's theory of gravity predicts the existence of gravitational waves.**

As in electrodynamics, the solution of eqs. (13.24) can be written in terms of retarded potentials

$$\bar{h}_{\mu\nu}(t, \mathbf{x}) = \frac{4G}{c^4} \int \frac{T_{\mu\nu}(t - \frac{|\mathbf{x}-\mathbf{x}'|}{c}, \mathbf{x}')}{|\mathbf{x}-\mathbf{x}'|} d^3x', \quad (13.26)$$

and the integral extends over the past light-cone of the event  $(t, \mathbf{x})$ . This equation represents the gravitational waves generated by the source  $T_{\mu\nu}$ .

We may now ask how eqs. (13.25) and (13.24) should be modified if, instead of considering the perturbation of a flat spacetime, we would consider the perturbation of a curved background. For example, suppose  $g_{\mu\nu}^0$  is the Schwarzschild solution for a non rotating black hole. In this case, it is possible to show that, by a suitable choice of the gauge, the Einstein equations written for certain combinations of the components of the metric tensor, can be reduced to a form similar to eqs. (13.24). However, since the background spacetime is now curved, the propagation of the waves will be modified with respect to the flat case. The curvature will act as a potential barrier by which waves are scattered and the final equation will have the form

$$\square_F \Phi - V(x^\mu) \Phi = -\frac{16\pi G}{c^4} T_{\mu\nu}, \quad (13.27)$$

where  $\Phi$  is the appropriate combination of metric functions,  $\square_F$  is the d'Alembertian of the flat spacetime and  $V$  is the potential barrier generated by the spacetime curvature. In other words, the perturbations of a spherically symmetric, stationary gravitational field would be described by a Schroedinger-like equation! A complete account on the theory of perturbations of black holes can be found in the book *The Mathematical Theory of Black Holes* by S. Chandrasekhar, Oxford: Clarendon Press, (1984).

## 13.2 How to choose the harmonic gauge

We shall now show that if the harmonic-gauge condition is not satisfied in a reference frame, we can always find a new frame where it is, by making an infinitesimal coordinate transformation

$$x^{\lambda'} = x^\lambda + \epsilon^\lambda, \quad (13.28)$$

provided

$$\square_F \epsilon_\rho = \frac{\partial h_\rho^\beta}{\partial x^\beta} - \frac{1}{2} \frac{\partial h_\beta^\beta}{\partial x^\rho}. \quad (13.29)$$

Indeed, when we change the coordinate system  $\Gamma^\lambda = g^{\mu\nu} \Gamma_{\mu\nu}^\lambda$  transforms according to equation (8.63), i.e.

$$\Gamma^{\lambda'} = \frac{\partial x^{\lambda'}}{\partial x^\rho} \Gamma^\rho - g^{\rho\sigma} \frac{\partial^2 x^{\lambda'}}{\partial x^\rho \partial x^\sigma}, \quad (13.30)$$

where, from eq. (13.28)

$$\frac{\partial x^{\lambda'}}{\partial x^\rho} = \delta_\rho^\lambda + \frac{\partial \epsilon^\lambda}{\partial x^\rho}.$$

If  $g_{\mu\nu} = \eta_{\mu\nu} + h_{\mu\nu}$  (see footnote after eq. (13.20))

$$\Gamma^\rho = \eta^{\rho k} \left\{ h^\mu_{k,\mu} - \frac{1}{2} h^\nu_{\nu,k} \right\}; \quad (13.31)$$

moreover

$$\begin{aligned} g^{\rho\sigma} \frac{\partial^2 x^{\lambda'}}{\partial x^\rho \partial x^\sigma} &= g^{\rho\sigma} \left[ \frac{\partial}{\partial x^\rho} \left( \frac{\partial x^{\lambda'}}{\partial x^\sigma} + \frac{\partial \epsilon^\lambda}{\partial x^\sigma} \right) \right] = \\ &g^{\rho\sigma} \left[ \frac{\partial}{\partial x^\rho} \left( \delta_\sigma^\lambda + \frac{\partial \epsilon^\lambda}{\partial x^\sigma} \right) \right] \simeq \eta^{\rho\sigma} \left[ \frac{\partial^2 \epsilon^\lambda}{\partial x^\rho \partial x^\sigma} \right] = \square_F \epsilon^\lambda, \end{aligned} \quad (13.32)$$

therefore in the new gauge the condition  $\Gamma^{\lambda'} = 0$  becomes

$$\Gamma^{\lambda'} = \eta^{\rho k} \left[ \delta_\rho^\lambda + \frac{\partial \epsilon^\lambda}{\partial x^\rho} \right] \left[ \frac{\partial h_k^\mu}{\partial x^\mu} - \frac{1}{2} \frac{\partial h^\nu_{\nu}}{\partial x^k} \right] - \square_F \epsilon^\lambda = 0. \quad (13.33)$$

If we neglect second order terms in  $h$  eq.(13.33) becomes

$$\Gamma^{\lambda'} = \eta^{\lambda k} \left[ \frac{\partial h_k^\mu}{\partial x^\mu} - \frac{1}{2} \frac{\partial h^\nu_{\nu}}{\partial x^k} \right] - \square_F \epsilon^\lambda = 0.$$

Contracting with  $\eta_{\lambda\alpha}$  and remembering that  $\eta_{\lambda\alpha}\eta^{\lambda k} = \delta_{\alpha}^k$  we finally find

$$\square_F \epsilon_{\alpha} = \frac{\partial h^{\mu}_{\alpha}}{\partial x^{\mu}} - \frac{1}{2} \frac{\partial h^{\nu}_{\nu}}{\partial x^{\alpha}}.$$

This equation can in principle be solved to find the components of  $\epsilon_{\alpha}$ , which identify the coordinate system in which the harmonic gauge condition is satisfied.

### 13.3 Plane gravitational waves

The simplest solution of the wave equation in vacuum (13.25) is a monochromatic plane wave

$$\bar{h}_{\mu\nu} = \Re \left\{ A_{\mu\nu} e^{ik_{\alpha}x^{\alpha}} \right\}, \quad (13.34)$$

where  $A_{\mu\nu}$  is the polarization tensor, i.e. the wave amplitude and  $\vec{k}$  is the wave vector. By direct substitution of (13.34) into the first equation we find

$$\begin{aligned} \square_F \bar{h}_{\mu\nu} &= \eta^{\alpha\beta} \frac{\partial}{\partial x^{\alpha}} \frac{\partial}{\partial x^{\beta}} \left( e^{ik_{\gamma}x^{\gamma}} \right) = \eta^{\alpha\beta} \frac{\partial}{\partial x^{\alpha}} \left[ ik_{\gamma} \frac{\partial x^{\gamma}}{\partial x^{\beta}} e^{ik_{\gamma}x^{\gamma}} \right] = \\ &= \eta^{\alpha\beta} \frac{\partial}{\partial x^{\alpha}} \left[ ik_{\gamma} \delta^{\gamma}_{\beta} e^{ik_{\gamma}x^{\gamma}} \right] = \eta^{\alpha\beta} \frac{\partial}{\partial x^{\alpha}} \left[ ik_{\beta} e^{ik_{\gamma}x^{\gamma}} \right] = \\ &= -\eta^{\alpha\beta} k_{\alpha} k_{\beta} e^{ik_{\gamma}x^{\gamma}} = 0, \quad \rightarrow \quad \eta^{\alpha\beta} k_{\alpha} k_{\beta} = 0, \end{aligned} \quad (13.35)$$

thus, (13.34) is a solution of (13.25) if  $\vec{k}$  is a null vector. In addition the harmonic gauge condition requires that

$$\frac{\partial}{\partial x^{\mu}} \bar{h}^{\mu}_{\nu} = 0, \quad (13.36)$$

which can be written as

$$\eta^{\mu\alpha} \frac{\partial}{\partial x^{\mu}} \bar{h}_{\alpha\nu} = 0. \quad (13.37)$$

Using eq. (13.34) it gives

$$\eta^{\mu\alpha} \frac{\partial}{\partial x^{\mu}} A_{\alpha\nu} e^{ik_{\gamma}x^{\gamma}} = 0 \quad \rightarrow \quad \eta^{\mu\alpha} A_{\alpha\nu} k_{\mu} = 0 \quad \rightarrow \quad k_{\mu} A^{\mu}_{\nu} = 0. \quad (13.38)$$

This further condition expresses the orthogonality of the wave vector and of the polarization tensor.

Since  $\bar{h}_{\mu\nu}$  is constant on those surfaces where

$$k_{\alpha}x^{\alpha} = \text{const}, \quad (13.39)$$

these are the equations of the **wavefront**. It is conventional to refer to  $k^0$  as  $\frac{\omega}{c}$ , where  $\omega$  is the frequency of the waves. Consequently

$$\vec{k} = \left( \frac{\omega}{c}, \mathbf{k} \right). \quad (13.40)$$

Since  $\vec{k}$  is a null vector

$$-(k_0)^2 + (k_x)^2 + (k_y)^2 + (k_z)^2 = 0, \quad \text{i.e.} \quad (13.41)$$

$$\omega = ck_0 = c\sqrt{(k_x)^2 + (k_y)^2 + (k_z)^2}, \quad (13.42)$$

where  $(k_x, k_y, k_z)$  are the components of the unit 3-vector  $\mathbf{k}$ .

### 13.4 The $TT$ -gauge

We now want to see how many of the ten components of  $h_{\mu\nu}$  have a real physical meaning, i.e. what are the degrees of freedom of a gravitational plane wave. Let us consider a wave propagating in flat spacetime along the  $x^1 = x$ -direction. Since  $h_{\mu\nu}$  is independent of  $y$  and  $z$ , eqs. (13.25) become (as before we raise and lower indices with  $\eta_{\mu\nu}$ )

$$\left(-\frac{\partial^2}{c^2 \partial t^2} + \frac{\partial^2}{\partial x^2}\right) \bar{h}^\mu{}_\nu = 0, \quad (13.43)$$

i.e.  $\bar{h}^\mu{}_\nu$  is an arbitrary function of  $t \pm \frac{x}{c}$ , and

$$\frac{\partial}{\partial x^\mu} \bar{h}^\mu{}_\nu = 0. \quad (13.44)$$

Let us consider, for example, a progressive wave  $\bar{h}^\mu{}_\nu = \bar{h}^\mu{}_\nu[\chi(t, x)]$ , where  $\chi(t, x) = t - \frac{x}{c}$ . Being

$$\begin{cases} \frac{\partial}{\partial t} \bar{h}^\mu{}_\nu = \frac{\partial \bar{h}^\mu{}_\nu}{\partial \chi} \frac{\partial \chi}{\partial t} = \frac{\partial \bar{h}^\mu{}_\nu}{\partial \chi}, \\ \frac{\partial}{\partial x} \bar{h}^\mu{}_\nu = \frac{\partial \bar{h}^\mu{}_\nu}{\partial \chi} \frac{\partial \chi}{\partial x} = -\frac{1}{c} \frac{\partial \bar{h}^\mu{}_\nu}{\partial \chi}, \end{cases} \quad (13.45)$$

eq. (13.44) gives

$$\frac{\partial}{\partial x^\mu} \bar{h}^\mu{}_\nu = \frac{1}{c} \frac{\partial \bar{h}^t{}_\nu}{\partial t} + \frac{\partial \bar{h}^x{}_\nu}{\partial x} = \frac{1}{c} \frac{\partial}{\partial \chi} [\bar{h}^t{}_\nu - \bar{h}^x{}_\nu] = 0. \quad (13.46)$$

This equation can be integrated, and the constants of integration can be set equal to zero because we are interested only in the time-dependent part of the solution. The result is

$$\begin{aligned} \bar{h}^t{}_t &= \bar{h}^x{}_t, & \bar{h}^t{}_y &= \bar{h}^x{}_y, \\ \bar{h}^t{}_x &= \bar{h}^x{}_x, & \bar{h}^t{}_z &= \bar{h}^x{}_z. \end{aligned} \quad (13.47)$$

We now observe that the harmonic gauge condition does not determine the gauge uniquely. Indeed, if we make an infinitesimal coordinate transformation

$$x^{\mu'} = x^\mu + \xi^\mu, \quad (13.48)$$

from eq. (13.30) we find that, if in the old frame  $\Gamma^\rho = 0$ , in the new frame  $\Gamma^{\lambda'} = 0$ , provided

$$\eta^{\rho\sigma} \frac{\partial^2 x^{\lambda'}}{\partial x^\rho \partial x^\sigma} = 0, \quad (13.49)$$

namely, if  $\xi^\mu$  satisfies the wave equation

$$\square_F \xi^\mu = 0. \quad (13.50)$$

Thus, we can use the four functions  $\xi^\mu$  to set to zero the following four quantities

$$\bar{h}^t{}_x = \bar{h}^t{}_y = \bar{h}^t{}_z = \bar{h}^y{}_y + \bar{h}^z{}_z = 0. \quad (13.51)$$

From eq. (13.47) it then follows that

$$\bar{h}^x_x = \bar{h}^x_y = \bar{h}^x_z = \bar{h}^t_t = 0. \quad (13.52)$$

The remaining non-vanishing components are  $\bar{h}^z_y$  and  $\bar{h}^y_y - \bar{h}^z_z$ . These components cannot be set equal to zero, because we have exhausted our gauge freedom.

From eqs. (13.51) and (13.52) it follows that

$$\bar{h}^\mu_\mu = \bar{h}^t_t + \bar{h}^x_x + \bar{h}^y_y + \bar{h}^z_z = 0, \quad (13.53)$$

and since

$$\bar{h}^\mu_\mu = h^\mu_\mu - 2h^\mu_\mu = -h^\mu_\mu, \quad (13.54)$$

it follows that

$$h^\mu_\mu = 0, \quad \rightarrow \quad \bar{h}^\mu_\nu \equiv h^\mu_\nu, \quad (13.55)$$

i.e. in this gauge  $h_{\mu\nu}$  and  $\bar{h}_{\mu\nu}$  coincide and are traceless. Thus, a plane gravitational wave propagating along the  $x$ -axis is characterized by two functions  $h_{xy}$  and  $h_{yy} = -h_{zz}$ , while the remaining components can be set to zero by choosing the gauge as we have shown:

$$h_{\mu\nu} = \begin{pmatrix} 0 & 0 & 0 & 0 \\ 0 & 0 & 0 & 0 \\ 0 & 0 & h_{yy} & h_{yz} \\ 0 & 0 & h_{yz} & -h_{yy} \end{pmatrix}. \quad (13.56)$$

**In conclusion, a gravitational wave has only two physical degrees of freedom which correspond to the two possible polarization states.** The gauge in which this is clearly manifested is called the  $TT$ -gauge, where ‘ $TT$ ’ indicates that the components of the metric tensor  $h_{\mu\nu}$  are different from zero only on the plane orthogonal to the direction of propagation (transverse), and that  $h_{\mu\nu}$  is traceless.

## 13.5 How does a gravitational wave affect the motion of a single particle

Consider a particle at rest in flat spacetime before the passage of the wave. We set an inertial frame attached to this particle, and take the  $x$ -axis coincident with the direction of propagation of an incoming  $TT$ -gravitational wave. The particle will follow a geodesic of the curved spacetime generated by the wave

$$\frac{d^2x^\alpha}{d\tau^2} + \Gamma^\alpha_{\mu\nu} \frac{dx^\mu}{d\tau} \frac{dx^\nu}{d\tau} \equiv \frac{dU^\alpha}{d\tau} + \Gamma^\alpha_{\mu\nu} U^\mu U^\nu = 0. \quad (13.57)$$

At  $t = 0$  the particle is at rest ( $U^\alpha = (1, 0, 0, 0)$ ) and the acceleration impressed by the wave will be

$$\left( \frac{dU^\alpha}{d\tau} \right)_{(t=0)} = -\Gamma^\alpha_{00} = -\frac{1}{2} \eta^{\alpha\beta} [h_{\beta 0,0} + h_{0\beta,0} - h_{00,\beta}], \quad (13.58)$$

but since we are in the  $TT$ -gauge it follows that

$$\left(\frac{dU^\alpha}{d\tau}\right)_{(t=0)} = 0. \quad (13.59)$$

Thus,  $U^\alpha$  remains constant also at later times, which means that the particle is not accelerated neither at  $t = 0$  nor later! It remains at a **constant coordinate position**, regardless of the wave. We conclude that **the study of the motion of a single particle is not sufficient to detect a gravitational wave.**

## 13.6 Geodesic deviation induced by a gravitational wave

We shall now study the relative motion of particles in the gravitational field produced by a gravitational wave.

Consider two neighbouring particles A and B, and choose a reference frame with origin coincident with the position of the particle A

$$x_A^\lambda = (ct, 0, 0, 0). \quad (13.60)$$

We shall assume that the two particles are initially at rest with respect to this frame, and that a plane-fronted gravitational wave reaches them at some time  $t = 0$ , propagating along the  $x$ -axis. We shall also assume that we are in the  $TT$ -gauge, so that the only non-vanishing components of the wave are those on the  $(y, z)$ -plane.

Be  $\tau = ct$  the proper time of the particle A. Since the two particles are initially at rest, they will remain at a constant coordinate position even later, when the wave arrives. However, since the metric changes, the proper distance between them will change. For example if the particle B is initially at some point on the  $y$ -axis

$$\Delta l = \int ds = \int_0^{y_B} |g_{yy}|^{\frac{1}{2}} dy = \int_0^{y_B} |1 + h^{TT}_{yy}|^{\frac{1}{2}} dy \neq \text{constant}. \quad (13.61)$$

Another way of studying the effect of the passage of the wave, is by means of the equation of geodesic deviation. Be  $\delta x^\mu$  the vector which separates the two particles, i.e. initially

$$\delta x^\mu = (0, x_B, y_B, z_B).$$

The equation of geodesic deviation

$$\frac{d^2 \delta x^\lambda}{d\tau^2} = R^\lambda{}_{\nu\beta\mu} \frac{dx^\beta}{d\tau} \frac{dx^\nu}{d\tau} \delta x^\mu \quad (13.62)$$

written in the gauge we have choosen, becomes

$$\frac{d^2}{d\tau^2} \delta x^\lambda = R^\lambda{}_{00\mu} \delta x^\mu. \quad (13.63)$$

If the gravitational wave is due to a perturbation of the flat metric, as discussed in this chapter, the metric can be written as  $g_{\mu\nu} = \eta_{\mu\nu} + h_{\mu\nu}$ , and the Riemann tensor

$$\begin{aligned} R_{iklm} &= \frac{1}{2} \left( \frac{\partial^2 g_{im}}{\partial x^k \partial x^l} + \frac{\partial^2 g_{kl}}{\partial x^i \partial x^m} - \frac{\partial^2 g_{il}}{\partial x^k \partial x^m} - \frac{\partial^2 g_{km}}{\partial x^i \partial x^l} \right) + \\ &+ g_{np} (\Gamma^n{}_{kl} \Gamma^p{}_{im} - \Gamma^n{}_{km} \Gamma^p{}_{il}), \end{aligned} \quad (13.64)$$

after neglecting terms which are second order in  $h_{\mu\nu}$ , becomes

$$R_{iklm} = \frac{1}{2} \left( \frac{\partial^2 h_{im}}{\partial x^k \partial x^l} + \frac{\partial^2 h_{kl}}{\partial x^i \partial x^m} - \frac{\partial^2 h_{il}}{\partial x^k \partial x^m} - \frac{\partial^2 h_{km}}{\partial x^i \partial x^l} \right) + O(h^2); \quad (13.65)$$

consequently

$$R_{i00m} = \frac{1}{2} \left( \frac{\partial^2 h_{im}}{\partial x^0 \partial x^0} + \frac{\partial^2 h_{00}}{\partial x^i \partial x^m} - \frac{\partial^2 h_{i0}}{\partial x^0 \partial x^m} - \frac{\partial^2 h_{0m}}{\partial x^i \partial x^0} \right) = \frac{1}{2} h_{im,00}^{TT}, \quad (13.66)$$

because in the  $TT$ -gauge  $h_{i0} = h_{00} = 0$ .  $i$  and  $m$  can assume only the values 2 and 3, i.e. they refer to the  $y$  and  $z$  components. It follows that

$$R^\lambda{}_{00m} = \eta^{\lambda i} R_{i00m} = \frac{1}{2} \eta^{\lambda i} \frac{\partial^2 h_{im}^{TT}}{c^2 \partial t^2}, \quad (13.67)$$

and the equation of geodesic deviation (13.63) becomes

$$\frac{d^2}{dt^2} \delta x^\lambda = \frac{1}{2} \eta^{\lambda i} \frac{\partial^2 h_{im}^{TT}}{\partial t^2} \delta x^m. \quad (13.68)$$

For  $t \leq 0$  the two particles are at rest relative to each other, and consequently

$$\delta x^j = \delta x_0^j, \quad \text{with} \quad \delta x_0^j = \text{const}, \quad t \leq 0. \quad (13.69)$$

Since  $h_{\mu\nu}$  is a small perturbation, when the wave arrives the relative position of the particles will change only by infinitesimal quantities, and therefore we put

$$\delta x^\lambda(t) = \delta x_0^\lambda + \delta x_1^\lambda(t), \quad t > 0, \quad (13.70)$$

where  $\delta x_1^\lambda(t)$  has to be considered as a small perturbation with respect to the initial position  $\delta x_0^\lambda$ . Substituting (13.70) in (13.68), remembering that  $\delta x_0^\lambda$  is a constant and retaining only terms of order  $O(h)$ , eq. (13.68) becomes

$$\frac{d^2}{dt^2} \delta x_1^\lambda = \frac{1}{2} \eta^{\lambda i} \frac{\partial^2 h_{ik}^{TT}}{\partial t^2} \delta x_0^k. \quad (13.71)$$

This equation can be integrated and the solution is

$$\delta x^\lambda = \delta x_0^\lambda + \frac{1}{2} \eta^{\lambda i} h^{TT}{}_{ik} \delta x_0^k, \quad (13.72)$$

which clearly shows the transverse nature of the gravitational wave; indeed, using the fact that if the wave propagates along  $x$  only the components  $h_{22} = -h_{33}$ ,  $h_{23} = h_{32}$  are different from zero, from eqs. (13.72) we find

$$\begin{aligned} \delta x^0 &= \delta x_0^0 + \frac{1}{2} \eta^{00} h^{TT}{}_{0k} \delta x_0^k = 0 \\ \delta x^1 &= \delta x_0^1 + \frac{1}{2} \eta^{11} h^{TT}{}_{1k} \delta x_0^k = \delta x_0^1 \\ \delta x^2 &= \delta x_0^2 + \frac{1}{2} \eta^{22} h^{TT}{}_{2k} \delta x_0^k = \delta x_0^2 + \frac{1}{2} \left( h^{TT}{}_{22} \delta x_0^2 + h^{TT}{}_{23} \delta x_0^3 \right) \\ \delta x^3 &= \delta x_0^3 + \frac{1}{2} \eta^{33} h^{TT}{}_{3k} \delta x_0^k = \delta x_0^3 + \frac{1}{2} \left( h^{TT}{}_{32} \delta x_0^2 + h^{TT}{}_{33} \delta x_0^3 \right). \end{aligned} \quad (13.73)$$

Thus, the particles will be accelerated only in the plane orthogonal to the direction of propagation.

Let us now study the effect of the polarization of the wave. Consider a plane wave whose nonvanishing components are (we omit in the following the superscript  $TT$ )

$$\begin{aligned} h_{yy} &= -h_{zz} = 2\Re \left\{ A_+ e^{i\omega(t - \frac{x}{c})} \right\}, \\ h_{yz} &= h_{zy} = 2\Re \left\{ A_\times e^{i\omega(t - \frac{x}{c})} \right\}. \end{aligned} \quad (13.74)$$

Consider two particles located, as indicated in figure (13.1) at  $(0, y_0, 0)$  and  $(0, 0, z_0)$ . Let us consider the polarization '+' first, i.e. let us assume

$$A_+ \neq 0 \quad \text{and} \quad A_\times = 0. \quad (13.75)$$

Assuming  $A_+$  real eqs. (13.74) give

$$h_{yy} = -h_{zz} = 2A_+ \cos \omega(t - \frac{x}{c}), \quad h_{yz} = h_{zy} = 0. \quad (13.76)$$

If at  $t = 0$   $\omega(t - \frac{x}{c}) = \frac{\pi}{2}$ , eqs. (13.73) written for the two particles for  $t > 0$  give

$$\begin{aligned} 1) \quad z &= 0, \quad y = y_0 + \frac{1}{2} h_{yy} y_0 = y_0 [1 + A_+ \cos \omega(t - \frac{x}{c})], \\ 2) \quad y &= 0, \quad z = z_0 + \frac{1}{2} h_{zz} z_0 = z_0 [1 - A_+ \cos \omega(t - \frac{x}{c})]. \end{aligned} \quad (13.77)$$

After a quarter of a period ( $\cos \omega(t - \frac{x}{c}) = -1$ )

$$\begin{aligned} 1) \quad z &= 0, \quad y = y_0 [1 - A_+], \\ 2) \quad y &= 0, \quad z = z_0 [1 + A_+]. \end{aligned} \quad (13.78)$$

After half a period ( $\cos \omega(t - \frac{x}{c}) = 0$ )

$$\begin{aligned} 1) \quad z &= 0, \quad y = y_0, \\ 2) \quad y &= 0, \quad z = z_0. \end{aligned} \quad (13.79)$$

After three quarters of a period ( $\cos \omega(t - \frac{x}{c}) = 1$ )

$$\begin{aligned} 1) \quad z &= 0, \quad y = y_0 [1 + A_+], \\ 2) \quad y &= 0, \quad z = z_0 [1 - A_+]. \end{aligned} \quad (13.80)$$

Similarly, if we consider a small ring of particles centered at the origin, the effect produced by a gravitational wave with polarization '+' is shown in figure (13.2).

Let us now see what happens if  $A_\times \neq 0$  and  $A_+ = 0$  :

$$h_{yy} = h_{zz} = 0, \quad h_{yz} = h_{zy} = 2A_\times \cos \omega(t - \frac{x}{c}). \quad (13.81)$$

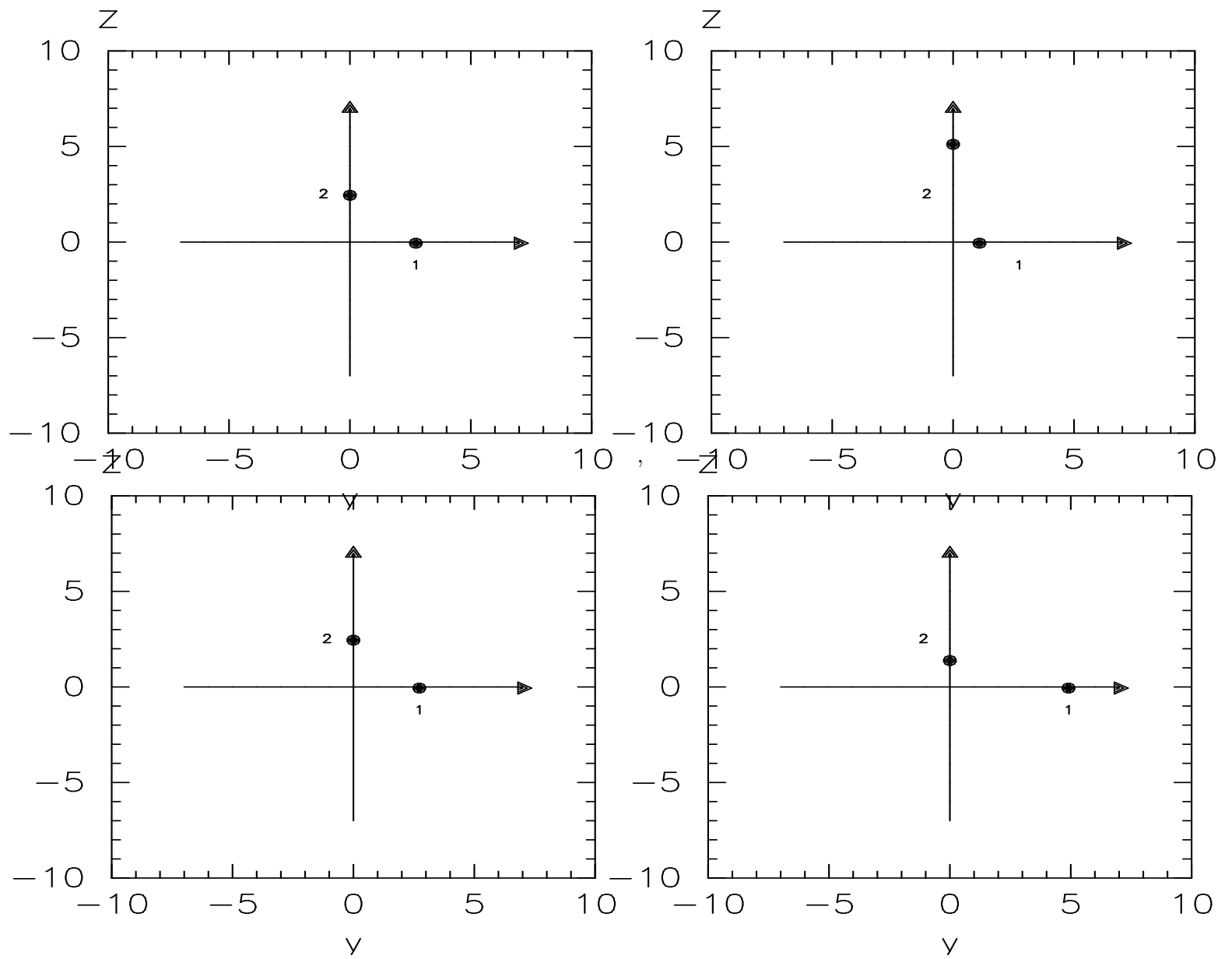

Figure 13.1:

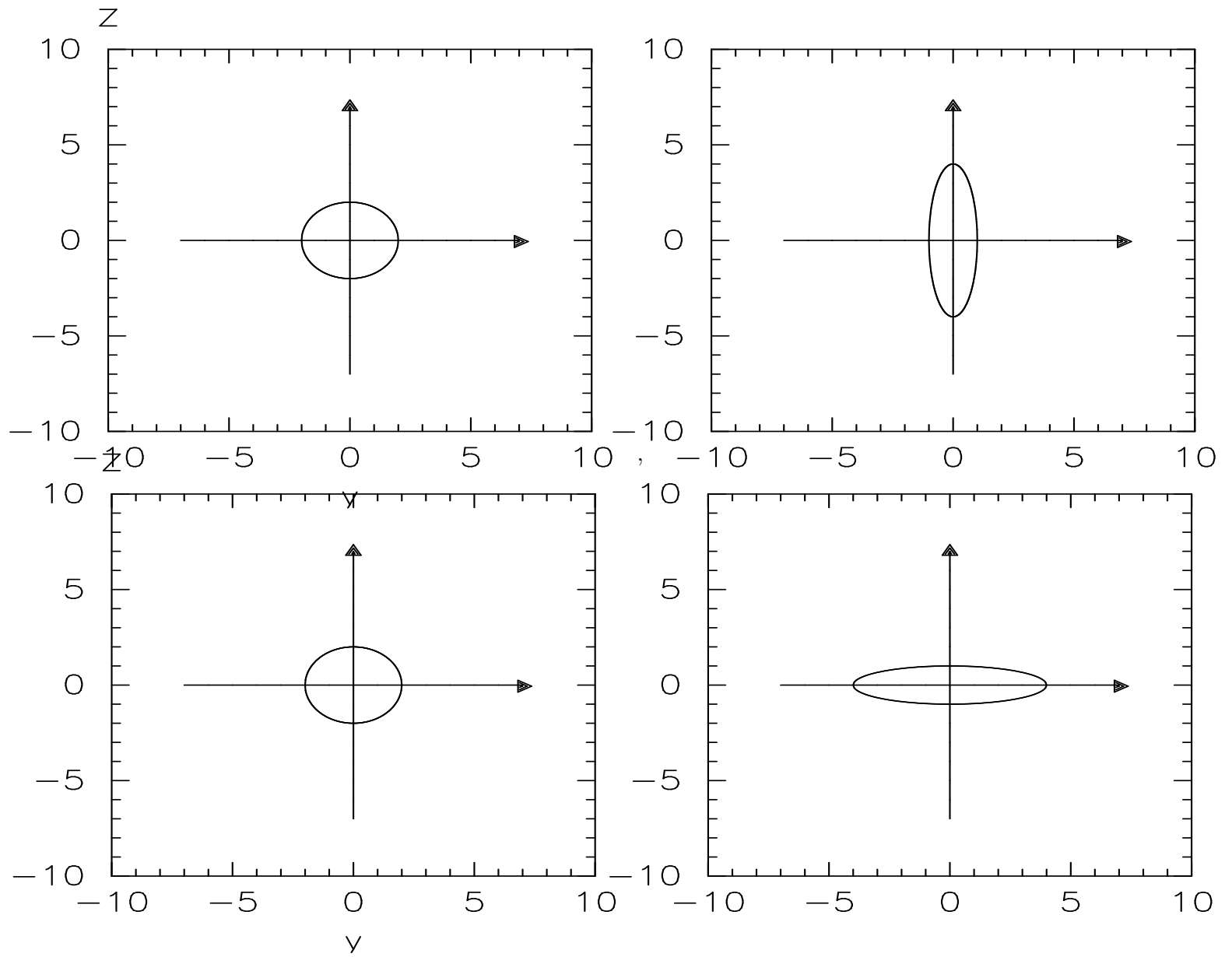

Figure 13.2:

Comparing with eqs. (13.73) we see that a generic particle initially at  $P = (y_0, z_0)$ , when  $t > 0$  will move according to the equations

$$\begin{aligned} y &= y_0 + \frac{1}{2}h_{yz} z_0 = y_0 + z_0 A_{\times} \cos \omega(t - \frac{x}{c}), \\ z &= z_0 + \frac{1}{2}h_{zy} y_0 = z_0 + y_0 A_{\times} \cos \omega(t - \frac{x}{c}). \end{aligned} \quad (13.82)$$

Let us consider four particles disposed as indicated in figure (13.3)

$$\begin{aligned} 1) \quad & y = r, & z = r, \\ 2) \quad & y = -r, & z = r, \\ 3) \quad & y = -r, & z = -r, \\ 4) \quad & y = r, & z = -r. \end{aligned} \quad (13.83)$$

As before, we shall assume that the initial time  $t = 0$  corresponds to  $\omega(t - \frac{x}{c}) = \frac{\pi}{2}$ . After a quarter of a period ( $\cos \omega(t - \frac{x}{c}) = -1$ ), the particles will have the following positions

$$\begin{aligned} 1) \quad & y = r[1 - A_{\times}], & z = r[1 - A_{\times}], \\ 2) \quad & y = r[-1 - A_{\times}], & z = r[1 + A_{\times}], \\ 3) \quad & y = r[-1 + A_{\times}], & z = r[-1 + A_{\times}], \\ 4) \quad & y = r[1 + A_{\times}], & z = r[-1 - A_{\times}]. \end{aligned} \quad (13.84)$$

After half a period  $\cos \omega(t - \frac{x}{c}) = 0$ , and the particles go back to the initial positions. After three quarters of a period, when  $\cos \omega(t - \frac{x}{c}) = 1$

$$\begin{aligned} 1) \quad & y = r[1 + A_{\times}], & z = r[1 + A_{\times}], \\ 2) \quad & y = r[-1 + A_{\times}], & z = r[1 - A_{\times}], \\ 3) \quad & y = r[-1 - A_{\times}], & z = r[-1 - A_{\times}], \\ 4) \quad & y = r[1 - A_{\times}], & z = r[-1 + A_{\times}]. \end{aligned} \quad (13.85)$$

The motion of the particles is indicated in figure (13.3).

It follows that a small ring of particles centered at the origin, will again become an ellipse, but rotated at  $45^\circ$  (see figure (13.4)) with respect to the case previously analysed. In conclusion, we can define  $A_+$  and  $A_{\times}$  as the **polarization amplitudes** of the wave. The wave will be linearly polarized when only one of the two amplitudes is different from zero.

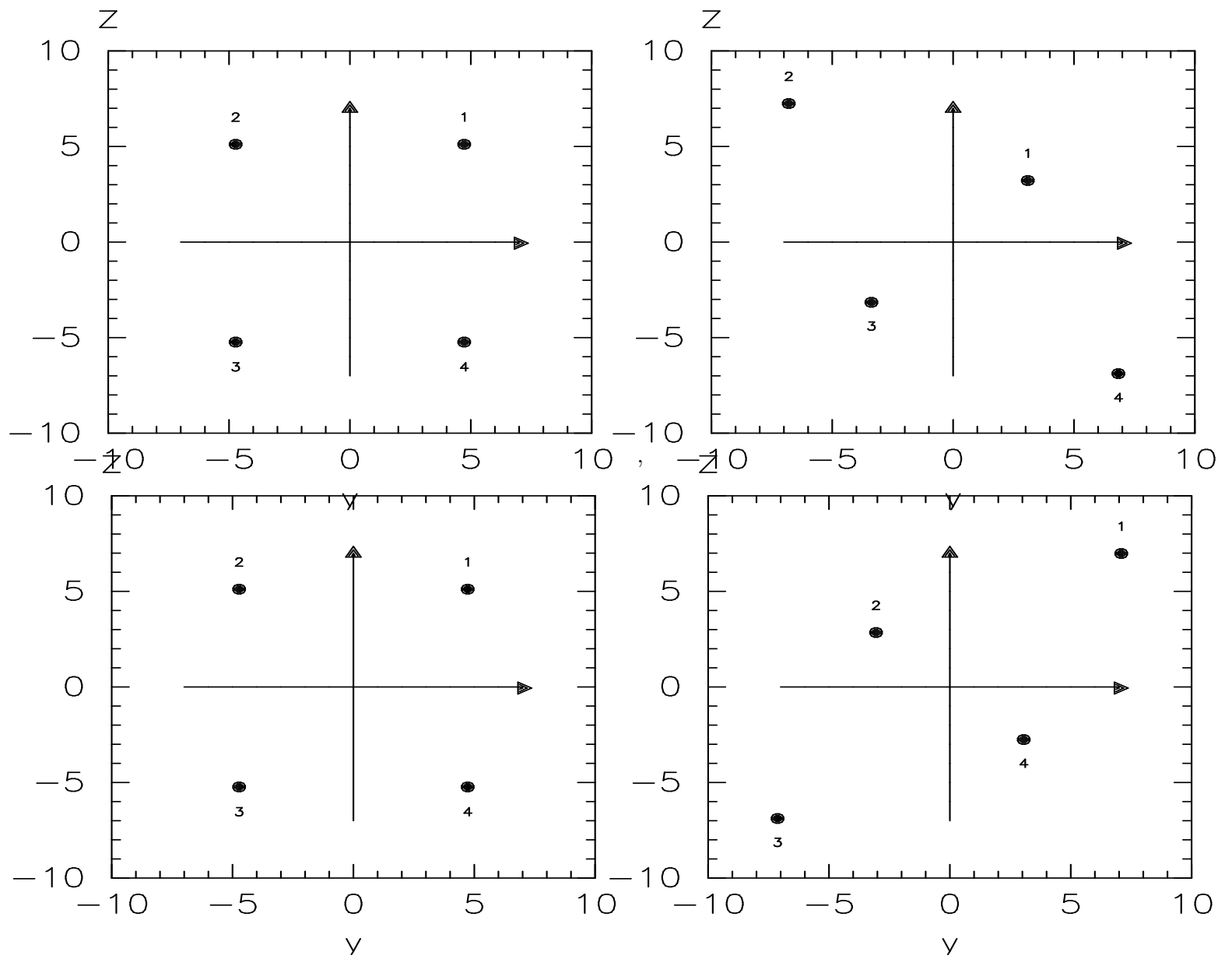

Figure 13.3:

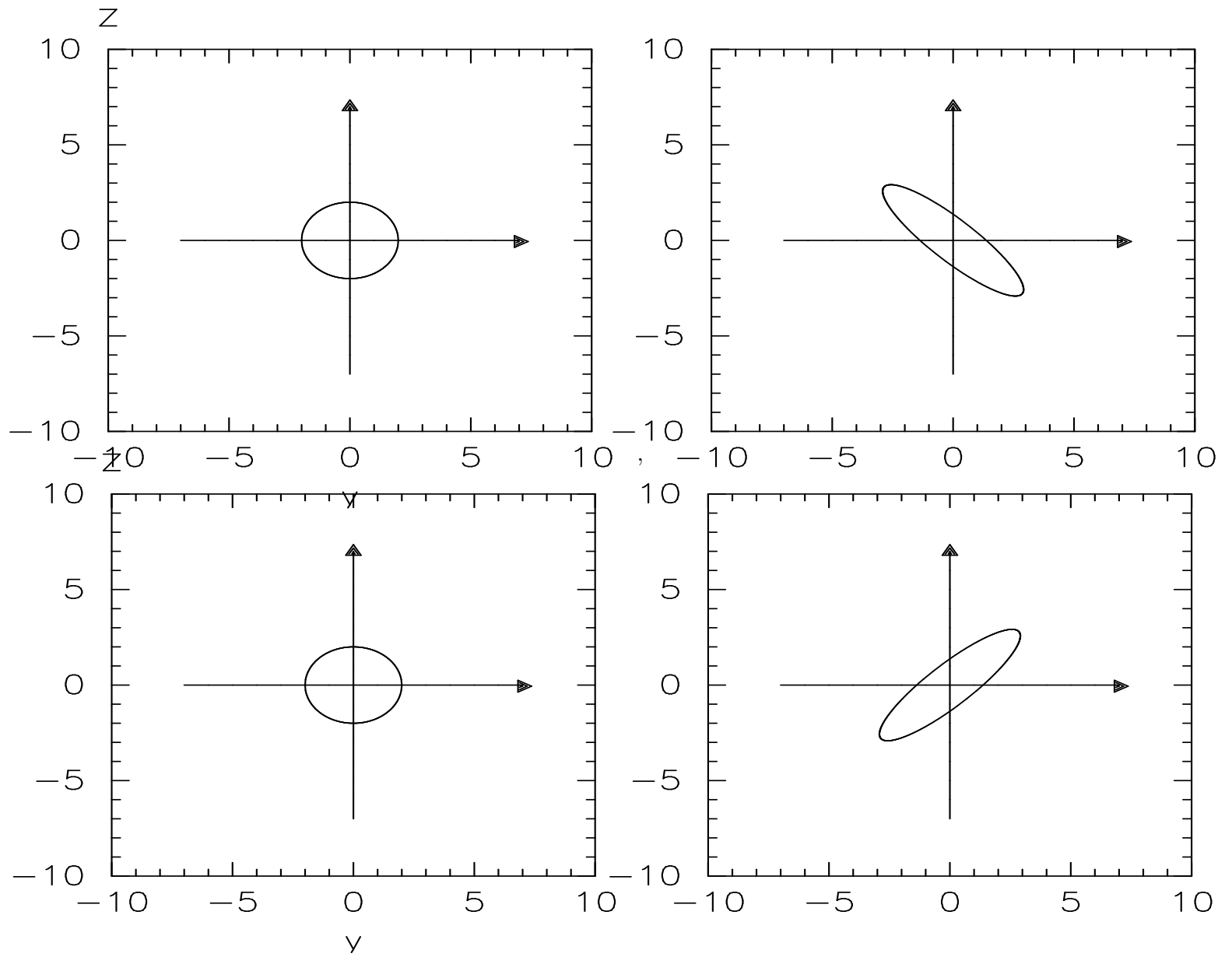

Figure 13.4:

# Chapter 14

## The Quadrupole Formalism

In this chapter we will introduce the quadrupole formalism which allows to estimate the gravitational energy and the waveforms emitted by an evolving physical system described by the stress-energy tensor  $T^{\mu\nu}$ . We shall solve eq. (13.24) under the following assumption: we shall assume that the region where the source is confined, namely

$$|x^i| < \epsilon, \quad T_{\mu\nu} \neq 0, \quad (14.1)$$

is much smaller than the wavelength of the emitted radiation,  $\lambda_{GW} = \frac{2\pi c}{\omega}$ . This implies that

$$\frac{2\pi c}{\omega} \gg \epsilon \quad \rightarrow \quad \epsilon \omega \ll c \quad \rightarrow \quad v_{\text{typical}} \ll c,$$

i.e. the velocities typical of the physical processes we are considering are much smaller than the speed of light; for this reason this is called *the slow-motion approximation*.

Let us consider the first equation in (13.24)

$$\square_F \bar{h}_{\mu\nu} = -\frac{16\pi G}{c^4} T_{\mu\nu}, \quad (14.2)$$

where

$$\bar{h}_{\mu\nu} = h_{\mu\nu} - \frac{1}{2}\eta_{\mu\nu}h \quad \text{and} \quad \square_F = \left[ -\frac{1}{c^2} \frac{\partial^2}{\partial t^2} + \nabla^2 \right].$$

By Fourier-expanding both  $\bar{h}_{\mu\nu}$  and  $T_{\mu\nu}$

$$\begin{aligned} T_{\mu\nu}(t, x^i) &= \int_{-\infty}^{+\infty} T_{\mu\nu}(\omega, x^i) e^{-i\omega t} d\omega, \\ \bar{h}_{\mu\nu}(t, x^i) &= \int_{-\infty}^{+\infty} \bar{h}_{\mu\nu}(\omega, x^i) e^{-i\omega t} d\omega, \quad i = 1, 3 \end{aligned} \quad (14.3)$$

eq. (14.2) becomes

$$\left[ \nabla^2 + \frac{\omega^2}{c^2} \right] \bar{h}_{\mu\nu}(\omega, x^i) = -\mathbf{K} T_{\mu\nu}(\omega, x^i) \quad (14.4)$$

where

$$\mathbf{K} = \frac{16\pi G}{c^4}. \quad (14.5)$$

We shall solve eq. (14.4) outside and inside the source, matching the two solutions across the source boundary.

*The exterior solution*

Outside the source  $T^{\mu\nu} = 0$  and eq. (14.4) becomes

$$\left[ \nabla^2 + \frac{\omega^2}{c^2} \right] \bar{h}_{\mu\nu}(\omega, x^i) = 0. \quad (14.6)$$

In polar coordinates, the Laplacian operator  $\nabla^2$  is

$$\nabla^2 = \frac{1}{r^2} \frac{\partial}{\partial r} \left[ r^2 \frac{\partial}{\partial r} \right] + \frac{1}{r^2 \sin \theta} \frac{\partial}{\partial \theta} \left[ \sin \theta \frac{\partial}{\partial \theta} \right] + \frac{1}{r^2 \sin^2 \theta} \frac{\partial^2}{\partial \phi^2}.$$

We shall consider the simplest solution of this equation, i.e. one which does not depend on  $\phi$  and  $\theta$ :

$$\bar{h}_{\mu\nu}(\omega, r) = \frac{A_{\mu\nu}(\omega)}{r} e^{i\frac{\omega}{c}r} + \frac{Z_{\mu\nu}(\omega)}{r} e^{-i\frac{\omega}{c}r}.$$

This solution represents a spherical wave, with an *ingoing* part ( $\sim e^{-i\frac{\omega}{c}r}$ ), and an *outgoing* ( $\sim e^{i\frac{\omega}{c}r}$ ) part; indeed, substituting in the second eq. (14.3)  $\bar{h}_{\mu\nu}(\omega, x^i)$  by  $\sim e^{\pm i\frac{\omega}{c}r}$  the result of the integration over  $\omega$  gives a function of  $(t \mp \frac{r}{c})$  respectively.

Since we are interested only in the wave emitted *from* the source, we shall set  $Z_{\mu\nu} = 0$ , and consider the solution

$$\bar{h}_{\mu\nu}(\omega, r) = \frac{A_{\mu\nu}(\omega)}{r} e^{i\frac{\omega}{c}r}. \quad (14.7)$$

This is the solution outside the source and on its boundary, where  $T^{\mu\nu}$  vanishes as well.  $A_{\mu\nu}$  is the wave amplitude to be found by solving the equations inside the source.

*The interior solution*

The wave equation

$$\left[ \nabla^2 + \frac{\omega^2}{c^2} \right] \bar{h}_{\mu\nu}(\omega, x^i) = -\mathbf{K} T_{\mu\nu}(\omega, x^i) \quad (14.8)$$

can be solved for each assigned value of the indices  $\mu, \nu$ , therefore in the integration of eq. (14.8) the functions  $\bar{h}_{\mu\nu}$  and  $T_{\mu\nu}$  will be considered as **scalar functions**. To solve eq. (14.8) let us integrate over the source volume

$$\int_V \left[ \nabla^2 + \frac{\omega^2}{c^2} \right] \bar{h}_{\mu\nu}(\omega, x^i) d^3x = -\mathbf{K} \int_V T_{\mu\nu}(\omega, x^i) d^3x.$$

The first term can be developed as follows

$$\int_V \nabla^2 \bar{h}_{\mu\nu}(\omega, x^i) d^3x = \int_V \text{div}[\nabla \bar{h}_{\mu\nu}] d^3x = \int_S (\nabla \bar{h}_{\mu\nu})^k dS_k \quad (14.9)$$

where  $\nabla \bar{h}_{\mu\nu}$  is the gradient of the scalar function  $\bar{h}_{\mu\nu}$ ,  $S$  is the surface surrounding the source volume, and we have applied Gauss theorem to the vector  $\nabla \bar{h}_{\mu\nu}$ . Using eq. (14.7)

the surface integral can be approximated as follows

$$\begin{aligned} \int_S (\nabla \bar{h}_{\mu\nu})^k dS_k &\simeq 4\pi \epsilon^2 \left( \frac{d}{dr} \frac{A_{\mu\nu}}{r} e^{i\frac{\omega}{c}r} \right)_{r=\epsilon} \\ &= 4\pi \epsilon^2 \left[ -\frac{A_{\mu\nu}}{r^2} e^{i\frac{\omega}{c}r} + \frac{A_{\mu\nu}}{r} \left( \frac{i\omega}{c} \right) e^{i\frac{\omega}{c}r} \right]_{r=\epsilon}; \end{aligned}$$

if we keep the leading term and discard terms of order  $\epsilon$ , we find

$$\int_V \nabla^2 \bar{h}_{\mu\nu}(\omega, x^i) d^3x \simeq -4\pi A_{\mu\nu}(\omega),$$

and eq. (14.8) becomes

$$-4\pi A_{\mu\nu} + \int_V \frac{\omega^2}{c^2} \bar{h}_{\mu\nu}(\omega, x^i) d^3x = -\mathbf{K} \int_V T_{\mu\nu}(\omega, x^i) d^3x. \quad (14.10)$$

The second term

$$\int_V \frac{\omega^2}{c^2} \bar{h}_{\mu\nu}(\omega, x^i) d^3x$$

satisfies the following inequality

$$\int_V \frac{\omega^2}{c^2} \bar{h}_{\mu\nu}(\omega, x^i) d^3x \lesssim |\bar{h}_{\mu\nu}|_{max} \frac{\omega^2}{c^2} \frac{4}{3}\pi\epsilon^3, \quad (14.11)$$

where  $|\bar{h}_{\mu\nu}|_{max}$  is the maximum reached by  $\bar{h}_{\mu\nu}$  in the volume  $V$ , and since the right-hand side of eq. (14.11) is of order  $\epsilon^3$  it can be neglected. Consequently eq. (14.10) becomes

$$-4\pi A_{\mu\nu}(\omega) = -\mathbf{K} \int_V T_{\mu\nu}(\omega, x^i) d^3x \quad (14.12)$$

i.e.

$$A_{\mu\nu}(\omega) = \frac{4G}{c^4} \int_V T_{\mu\nu}(\omega, x^i) d^3x.$$

Thus, the solution of the wave equation inside the source gives the wave amplitude  $A_{\mu\nu}(\omega)$  as an integral of the stress-energy tensor of the source over the source volume. Knowing  $A_{\mu\nu}(\omega)$  we finally find

$$\bar{h}_{\mu\nu}(\omega, r) = \frac{4G}{c^4} \cdot \frac{e^{i\frac{\omega}{c}r}}{r} \int_V T_{\mu\nu}(\omega, x^i) d^3x, \quad (14.13)$$

or, by the inverse Fourier transform

$$\bar{h}_{\mu\nu}(t, r) = \frac{4G}{c^4} \frac{1}{r} \int_V T_{\mu\nu}(t - \frac{r}{c}, x^i) d^3x. \quad (14.14)$$

This is the gravitational signal emitted by the source.

The integral in (14.14) can be further simplified, but in the meantime note that:

1) The solution (14.14) for  $\bar{h}_{\mu\nu}$  automatically satisfies the second eq. (13.24), i.e. the harmonic gauge condition

$$\frac{\partial}{\partial x^\mu} \bar{h}^\mu{}_\nu = 0.$$

To prove this, we first notice that the solution (14.14) is equivalent to the expression (13.26)

$$\bar{h}_{\mu\nu}(t, \mathbf{x}) = \frac{4G}{c^4} \int_V \frac{T_{\mu\nu}(t - \frac{|\mathbf{x}-\mathbf{x}'|}{c}, \mathbf{x}')}{|\mathbf{x}-\mathbf{x}'|} d^3x'; \quad (14.15)$$

indeed, since

$$|\mathbf{x}'| < \epsilon, \quad \text{and} \quad r \gg \epsilon, \quad (14.16)$$

then

$$r \equiv |\mathbf{x}| \simeq |\mathbf{x}-\mathbf{x}'|. \quad (14.17)$$

By defining the following function

$$g(\vec{x} - \vec{x}') \equiv \frac{4G}{c^4} \frac{1}{|\mathbf{x}-\mathbf{x}'|} \delta \left[ t' - \left( t - \frac{|\mathbf{x}-\mathbf{x}'|}{c} \right) \right], \quad (14.18)$$

where  $\vec{x} = (ct, \mathbf{x})$  and  $\vec{x}' = (ct', \mathbf{x}')$ , eq. (14.15) can be written as a four-dimensional integral as follows

$$\bar{h}_{\mu\nu}(\vec{x}) = \int_\Omega T_{\mu\nu}(\vec{x}') g(\vec{x} - \vec{x}') d^4x', \quad (14.19)$$

where  $\Omega \equiv V \times I$ , and  $I$  is the time interval to be taken such that  $g(\vec{x} - \vec{x}')$  vanishes at the extrema of  $I$ ; this happens if  $I$  is so large that, for all  $\mathbf{x}' \in V$ , the expression  $t - \frac{|\mathbf{x}-\mathbf{x}'|}{c}$  is inside  $I$ ; indeed, from the definition (14.18)  $g$  is different from zero only for  $t' = t - \frac{|\mathbf{x}-\mathbf{x}'|}{c}$ .

Since  $g$  is a function of the *difference*  $(\vec{x} - \vec{x}')$ , then

$$\frac{\partial}{\partial x^\mu} [g(\vec{x} - \vec{x}')] = -\frac{\partial}{\partial x^{\mu'}} [g(\vec{x} - \vec{x}')] . \quad (14.20)$$

Consequently,

$$\frac{\partial}{\partial x^\mu} \bar{h}^{\mu\nu}(\vec{x}) = \int_\Omega T^{\mu\nu}(\vec{x}') \frac{\partial}{\partial x^\mu} g(\vec{x} - \vec{x}') d^4x' = - \int_\Omega T^{\mu\nu}(\vec{x}') \frac{\partial}{\partial x^{\mu'}} g(\vec{x} - \vec{x}') d^4x' . \quad (14.21)$$

Integrating by parts, and using the fact that  $T^{\mu\nu} = 0$  on the boundary of  $V$  and  $g = 0$  on the boundary of  $I$ , we have

$$\frac{\partial}{\partial x^\mu} \bar{h}^{\mu\nu}(\vec{x}) = \int_\Omega g(\vec{x} - \vec{x}') \frac{\partial}{\partial x^{\mu'}} T^{\mu\nu}(\vec{x}') d^4x' = 0 \quad (14.22)$$

because the stress-energy tensor satisfies the conservation law  $T^{\mu\nu}{}_{,\nu} = 0$ . **Q.E.D.**

2) In order to extract the physical components of the wave we still have to project  $\bar{h}_{\mu\nu}$  on the **TT**-gauge.

3) Eq. (14.14) has been derived on two very strong assumptions: weak field ( $g_{\mu\nu} = \eta_{\mu\nu} + h_{\mu\nu}$ ) and slow motion ( $v_{\text{typical}} \ll c$ ). For this reason that expression has to be considered as an estimate of the emitted radiation by the system, unless the two conditions are really satisfied.

## 14.1 The Tensor Virial Theorem

In order to simplify the integral in eq. (14.14) we shall use the conservation law that  $T_{\mu\nu}$  satisfies (see chapter 7)

$$\frac{\partial T^{\mu\nu}}{\partial x^\nu} = 0, \quad \rightarrow \quad \frac{1}{c} \frac{\partial T^{\mu 0}}{\partial t} = - \frac{\partial T^{\mu k}}{\partial x^k}, \quad \mu = 0, 3, \quad k = 1, 3. \quad (14.23)$$

Let us integrate this equation over the source volume, assuming the index  $\mu$  is fixed

$$\frac{1}{c} \frac{\partial}{\partial t} \int_V T^{\mu 0} d^3x = - \int_V \frac{\partial T^{\mu k}}{\partial x^k} d^3x.$$

By Gauss' theorem, the integral over the volume is equal to the flux of  $T^{\mu k}$  across the surface  $S$  enclosing that volume, thus the right-hand-side becomes

$$\int_V \frac{\partial T^{\mu k}}{\partial x^k} d^3x = \int_S T^{\mu k} dS_k.$$

By definition, on  $S$   $T^{\mu\nu} = 0$  and consequently the surface integral vanishes; thus

$$\frac{1}{c} \frac{\partial}{\partial t} \int_V T^{\mu 0} d^3x = 0, \quad \rightarrow \quad \int_V T^{\mu 0} d^3x = \text{const.} \quad (14.24)$$

From eq. (14.14) it follows that

$$\bar{h}^{\mu 0} = \text{const}, \quad \mu = 0, 3,$$

and since we are interested in the time-dependent part of the field we shall put

$$\bar{h}^{\mu 0} = 0, \quad \mu = 0, 3. \quad (14.25)$$

(Indeed, we shall show that in the **TT**-gauge  $\bar{h}^{\mu 0} = 0$ .) We shall now prove the **Tensor-Virial Theorem** which establishes that

$$\frac{1}{c^2} \frac{\partial^2}{\partial t^2} \int_V T^{00} x^k x^n d^3x = 2 \int_V T^{kn} d^3x, \quad k, n = 1, 3. \quad (14.26)$$

Let us consider the space-components of the conservation law (14.23)

$$\frac{\partial T^{n0}}{\partial x^0} = - \frac{\partial T^{ni}}{\partial x^i}, \quad i, n = 1, 3;$$

multiply both members by  $x^k$  and integrate over the source volume

$$\begin{aligned} \frac{1}{c} \frac{\partial}{\partial t} \int_V T^{n0} x^k d^3x &= - \int_V \frac{\partial T^{ni}}{\partial x^i} x^k d^3x \\ &= - \left[ \int_V \frac{\partial (T^{ni} x^k)}{\partial x^i} d^3x - \int_V T^{ni} \frac{\partial x^k}{\partial x^i} d^3x \right] \\ &= - \int_S (T^{ni} x^k) dS_i + \int_V T^{nk} d^3x, \end{aligned}$$

(remember that  $\frac{\partial x^k}{\partial x^i} = \delta_i^k$ ). As before  $\int_S (T^{ni} x^k) dS_i = 0$ , therefore

$$\frac{1}{c} \frac{\partial}{\partial t} \int_V T^{n0} x^k d^3x = \int_V T^{nk} d^3x.$$

Since  $T^{nk}$  is symmetric we can rewrite this equation in the following form

$$\frac{1}{2c} \frac{\partial}{\partial t} \int_V (T^{n0} x^k + T^{k0} x^n) d^3x = \int_V T^{nk} d^3x. \quad (14.27)$$

Let us now consider the 0 component of the conservation law

$$\frac{1}{c} \frac{\partial T^{00}}{\partial t} + \frac{\partial T^{0i}}{\partial x^i} = 0, \quad i = 1, 3$$

multiply by  $x^k x^n$  and integrate over  $V$

$$\begin{aligned} & \frac{1}{c} \frac{\partial}{\partial t} \int_V T^{00} x^k x^n d^3x = - \int_V \frac{\partial T^{0i}}{\partial x^i} x^k x^n d^3x \\ & = - \left[ \int_V \frac{\partial (T^{0i} x^k x^n)}{\partial x^i} d^3x - \int_V \left( T^{0i} \frac{\partial x^k}{\partial x^i} x^n + T^{0i} x^k \frac{\partial x^n}{\partial x^i} \right) d^3x \right] \\ & = - \int_S (T^{0i} x^k x^n) dS_i + \int_V (T^{0k} x^n + T^{0n} x^k) d^3x \end{aligned}$$

the first integral vanishes and this equation becomes

$$\frac{1}{c} \frac{\partial}{\partial t} \int_V T^{00} x^k x^n d^3x = \int_V (T^{0k} x^n + T^{0n} x^k) d^3x.$$

If we now differentiate with respect to  $x^0$  we find

$$\frac{1}{c^2} \frac{\partial^2}{\partial t^2} \int_V T^{00} x^k x^n d^3x = \frac{1}{c} \frac{\partial}{\partial t} \int_V (T^{0k} x^n + T^{0n} x^k) d^3x,$$

and using eq. (14.27) we finally find

$$\frac{1}{c^2} \frac{\partial^2}{\partial t^2} \int_V T^{00} x^k x^n d^3x = 2 \int_V T^{kn} d^3x, \quad k, n = 1, 3. \quad (14.28)$$

The left-hand-side of this equation is the second time derivative of the **quadrupole moment tensor** of the system

$$q^{kn}(t) = \frac{1}{c^2} \int_V T^{00}(t, x^i) x^k x^n d^3x, \quad k, n = 1, 3, \quad (14.29)$$

which is a function of time only. Thus, in conclusion

$$\int_V T^{kn}(t, x^i) d^3x = \frac{1}{2} \frac{d^2}{dt^2} q^{kn}(t).$$

By using eqs. (14.14) and (14.25) we finally find

$$\begin{cases} \bar{h}^{\mu 0} = 0, & \mu = 0, 3 \\ \bar{h}^{ik}(t, r) = \frac{2G}{c^4 r} \cdot \left[ \frac{d^2}{dt^2} q^{ik}(t - \frac{r}{c}) \right] \end{cases} . \quad (14.30)$$

This is the gravitational wave emitted by a gravitating system evolving in time. It can be composed of masses or of any form of energy, because mass and energy are both sources of the gravitational field.

### NOTE THAT

- 1)  $\frac{G}{c^4} \sim 8 \cdot 10^{-50} \text{ s}^2/\text{g cm}$  : this is the reason why gravitational waves are extremely weak!!
- 3) In order to make the physical degrees of freedom explicitly manifest we still have to transform to the **TT**-gauge
- 4) These equations have been derived on very strong assumptions: one is that  $T^{\mu\nu}_{,\nu} = 0$ , i.e. that the motion of the bodies is dominated by non-gravitational forces. However, and remarkably, the result (14.30) depends only on the sources motion and not on the forces acting on them.
- 5) Gravitational radiation has a quadrupolar nature. A system of accelerated charged particles has a time-varying dipole moment

$$\vec{d}_{EM} = \sum_i q_i \vec{r}_i$$

and it will emit dipole radiation, the flux of which depends on the second time derivative of  $\vec{d}_{EM}$ . For an isolated system of masses we can define a gravitational dipole moment

$$\vec{d}_G = \sum_i m_i \vec{r}_i,$$

which satisfies the conservation law of the total momentum of an isolated system

$$\frac{d}{dt} \vec{d}_G = 0.$$

For this reason, gravitational waves do not have a dipole contribution. It should be stressed that for a spherical or axisymmetric distribution of matter (or energy) the quadrupole moment is a constant, even if the body is rotating. Thus, a spherical or axisymmetric star does not emit gravitational waves; similarly a star which collapses in a perfectly spherically symmetric way has a vanishing  $\frac{d^2 q^{ik}}{dt^2}$  and does not emit gravitational waves. To produce these waves we need a certain degree of asymmetry, as it occurs for instance in the non-radial pulsations of stars, in a non spherical gravitational collapse, in the coalescence of massive bodies etc.

## 14.2 How to transform to the TT-gauge

The solution (14.30) describes a spherical wave far from the emitting source. Locally, it looks like a plane wave propagating along the direction of the unit vector orthogonal to the wavefront

$$n^\alpha = (0, n^i), \quad i = 1, 3 \quad (14.31)$$

where

$$n^i = \frac{x^i}{r}. \quad (14.32)$$

In order to express this waveform in the TT-gauge we shall make an infinitesimal coordinate transformation  $x^\mu \rightarrow x^\mu + \epsilon^\mu$  and choose the vector  $\epsilon^\mu$  which satisfies the wave equation  $\square_F \epsilon^\mu = 0$ , so that the harmonic gauge condition is preserved, as explained in chapter 14. The conditions we will impose on the perturbed metric are

$$\begin{aligned} \bar{h}'_{\alpha\beta} \delta^{\alpha\beta} &= 0, & \text{vanishing trace} \\ \bar{h}'_{\alpha\beta} n^\beta &= 0, & \text{transverse wave condition.} \end{aligned}$$

It should be mentioned that these conditions imply that  $\bar{h}'^{\mu 0} = 0$ ,  $\mu = 0, 3$  as required in eq. (14.25). Indeed, given the wave-vector  $k^\mu = (cost, rn^i)$  we know by eq. (13.38) that  $k^\mu \bar{h}'_{\mu\nu} = 0$ , i.e.

$$k^0 \bar{h}'_{0\nu} + rn^i \bar{h}'_{i\nu} = 0.$$

The second term vanishes because of the transverse wave condition, therefore

$$h'_{0\nu} = 0.$$

We remind here that, as shown in eq. (13.55), in the TT-gauge  $\bar{h}_{\mu\nu}$  and  $h_{\mu\nu}$  coincide.

**To hereafter, we shall work in the 3-dimensional euclidean space with metric  $\delta_{ij}$ . Consequently, there will be no difference between covariant and contravariant indices.** As a first step, we define the operator which projects a vector onto the plane orthogonal to the direction of  $\mathbf{n}$

$$P_{jk} \equiv \delta_{jk} - n_j n_k. \quad (14.33)$$

Indeed, it is easy to verify that for any vector  $V^j$ ,  $P_{jk} V^k$  is orthogonal to  $n^j$ , i.e.  $(P_{jk} V^k) n^j = 0$ , and that

$$P^j_k P^k_l V^l = P^j_l V^l. \quad (14.34)$$

Note that  $P_{jk} = P_{kj}$ , i.e.  $P_{jk}$  is **symmetric**. The projector is **transverse**, i.e.

$$n^j P_{jk} = 0. \quad (14.35)$$

Then, we define the **transverse–traceless projector**:

$$\mathcal{P}_{jkmn} \equiv P_{jm} P_{kn} - \frac{1}{2} P_{jk} P_{mn}. \quad (14.36)$$

which “extracts” the transverse-traceless part of a  $\begin{pmatrix} 0 \\ 2 \end{pmatrix}$  tensor. In fact, substituting the definition (14.36), it is easy to see that it satisfies the following properties

- $\mathcal{P}_{jklm} = \mathcal{P}_{lmjk}$
- $\mathcal{P}_{jklm} = \mathcal{P}_{kjlm}$
- $\mathcal{P}_{jklm} = \mathcal{P}_{jkm l}$   
and

$$\mathcal{P}_{jkmn}\mathcal{P}_{mnr s} = \mathcal{P}_{jkr s}; \quad (14.37)$$

- it is transverse:

$$n^j\mathcal{P}_{jkmn} = n^k\mathcal{P}_{jkmn} = n^m\mathcal{P}_{jkmn} = n^n\mathcal{P}_{jkmn} = 0; \quad (14.38)$$

- it is traceless:

$$\delta^{jk}\mathcal{P}_{jkmn} = \delta^{mn}\mathcal{P}_{jkmn} = 0. \quad (14.39)$$

Since  $h_{jk}$  and  $\bar{h}_{jk}$  differ only by the trace, and since the projector  $\mathcal{P}_{jklm}$  extracts the traceless part of a tensor (eq. 14.39), the components of the perturbed metric tensor in the **TT**-gauge can be obtained by applying the projector  $\mathcal{P}_{jkmn}$  either to  $h_{jk}$  or to  $\bar{h}_{jk}$

$$h_{jk}^{\mathbf{TT}} = \mathcal{P}_{jkmn}h_{mn} = \mathcal{P}_{jkmn}\bar{h}_{mn}. \quad (14.40)$$

By applying  $\mathcal{P}$  on  $\bar{h}_{jk}$  defined in eq. (14.30) we get

$$\begin{cases} h_{\mu 0}^{\mathbf{TT}} = 0, & \mu = 0, 3 \\ h_{jk}^{\mathbf{TT}}(t, r) = \frac{2G}{c^4 r} \cdot \left[ \frac{d^2}{dt^2} Q_{jk}^{\mathbf{TT}}(t - \frac{r}{c}) \right] \end{cases} \quad (14.41)$$

where

$$Q_{jk}^{\mathbf{TT}} \equiv \mathcal{P}_{jkmn}q_{mn} \quad (14.42)$$

is the **transverse–traceless part of the quadrupole moment**. Sometimes it is useful to define the **reduced quadrupole moment**  $Q_{jk}$

$$Q_{jk} \equiv q_{jk} - \frac{1}{3}\delta_{jk}q_m^m \quad (14.43)$$

whose trace is zero by definition, i.e.

$$\delta^{jk}Q_{jk} = 0, \quad (14.44)$$

and from eq. (14.39), it follows that

$$Q_{jk}^{\mathbf{TT}} = \mathcal{P}_{jkmn}q_{mn} = \mathcal{P}_{jkmn}Q_{mn}. \quad (14.45)$$

### 14.3 Gravitational wave emitted by a harmonic oscillator

Let us consider a harmonic oscillator composed of two equal masses  $m$  oscillating at a frequency  $\nu = \frac{\omega}{2\pi}$  with amplitude  $A$ . Be  $l_0$  the proper length of the string when the system is at rest. Assuming that the oscillator moves on the  $x$ -axis, the position of the two masses will be

$$\begin{cases} x_1 = -\frac{1}{2}l_0 - A \cos \omega t \\ x_2 = +\frac{1}{2}l_0 + A \cos \omega t \end{cases} .$$

The 00-component of the stress-energy tensor of the system is

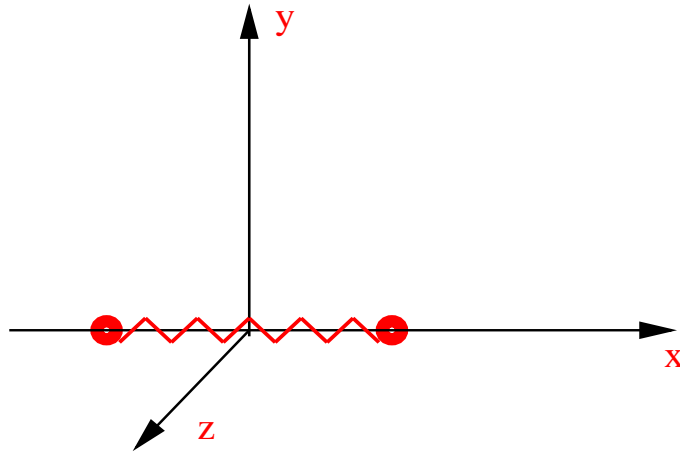

$$T^{00} = \sum_{n=1}^2 cp^0 \delta(x - x_n) \delta(y) \delta(z);$$

and since  $v \ll c$ ,  $\rightarrow \gamma \sim 1 \rightarrow p^0 = mc$ , it reduces to

$$T^{00} = mc^2 \sum_{n=1}^2 \delta(x - x_n) \delta(y) \delta(z);$$

the  $xx$ -component of the quadrupole moment  $q^{ik}(t) = \frac{1}{c^2} \int_V T^{00}(t, x^n) x^i x^k dx^3$  is

$$\begin{aligned} q^{xx} = q_{xx} &= m \left[ \int_V \delta(x - x_1) x^2 dx \delta(y) dy \delta(z) dz \right. \\ &\quad \left. + \int_V \delta(x - x_2) x^2 dx \delta(y) dy \delta(z) dz \right] \\ &= m [x_1^2 + x_2^2] = m \left[ \frac{1}{2}l_0^2 + 2A^2 \cos^2 \omega t + 2Al_0 \cos \omega t \right] \\ &= m [cost + A^2 \cos 2\omega t + 2Al_0 \cos \omega t], \end{aligned} \tag{14.46}$$

where we have used the trigonometric expression  $\cos 2\alpha = 2 \cos^2 \alpha - 1$ . The  $zz$ -component of the quadrupole moment is

$$q^{zz} = m \left[ \int_V \delta(x - x_1) dx \delta(y) dy \delta(z) z^2 dz + \int_V \delta(x - x_2) dx \delta(y) dy \delta(z) z^2 dz \right] = 0$$

because  $\int_V z^2 \delta(z) dz = 0$ . Since the motion is confined to the  $x$ -axis, all remaining components of  $q_{ij}$  vanish. Let us now compute the reduced quadrupole moment  $Q_{ij} = q_{ij} - \frac{1}{3} \delta_{ij} q^k_k$ ; since  $q^k_k = \eta^{ik} q_{ik} = \eta^{xx} q_{xx} = q_{xx}$  we find

$$\begin{aligned} Q_{xx} &= q_{xx} - \frac{1}{3} q_{xx} = \frac{2}{3} q_{xx} \\ Q_{yy} &= Q_{zz} = -\frac{1}{3} q_{xx} \\ Q_{xy} &= 0. \end{aligned} \tag{14.47}$$

We shall compute, as an example, the wave emerging in the  $z$ -direction; in this case  $\mathbf{n} = \frac{\mathbf{x}}{r} \rightarrow (0, 0, 1)$  and

$$P_{jk} = \delta_{jk} - n_j n_k = \begin{pmatrix} 1 & 0 & 0 \\ 0 & 1 & 0 \\ 0 & 0 & 0 \end{pmatrix}.$$

By applying to  $Q_{ij}$  the transverse-traceless projector  $P_{jkmn}$  constructed from  $P_{jk}$ , we find

$$\begin{aligned} Q^{\mathbf{TT}}_{xx} &= \left( P_{xm} P_{xn} - \frac{1}{2} P_{xx} P_{mn} \right) Q_{mn} \\ &= \left( P_{xx} P_{xx} - \frac{1}{2} P_{xx}^2 \right) Q_{xx} - \frac{1}{2} P_{xx} P_{yy} Q_{yy} = \frac{1}{2} (Q_{xx} - Q_{yy}), \\ Q^{\mathbf{TT}}_{xy} &= \left( P_{xm} P_{yn} - \frac{1}{2} P_{xy} P_{mn} \right) Q_{mn} = P_{xx} P_{yy} Q_{xy} = 0, \\ Q^{\mathbf{TT}}_{zz} &= \left( P_{zm} P_{zn} - \frac{1}{2} P_{zz} P_{mn} \right) Q_{mn} = 0. \end{aligned} \tag{14.48}$$

Using these expressions it is easy to show that eqs. (14.41) become

$$\begin{cases} h^{\mathbf{TT}}_{\mu 0} = 0 \\ h^{\mathbf{TT}}_{zi} = 0, & h^{\mathbf{TT}}_{xy} = \frac{2G}{c^4 z} \frac{d^2}{dt^2} Q_{xy} = 0 \\ h^{\mathbf{TT}}_{xx} = -h^{\mathbf{TT}}_{yy} = \frac{G}{c^4 z} \frac{d^2}{dt^2} (Q_{xx} - Q_{yy}), \end{cases} \tag{14.49}$$

and using eqs. (14.47) and (14.46)

$$\begin{aligned} h^{\mathbf{TT}}_{xx} &= -h^{\mathbf{TT}}_{yy} = \frac{G}{c^4 z} \cdot \left[ \frac{d^2}{dt^2} q_{xx} \left( t - \frac{z}{c} \right) \right], \\ &= -\frac{2Gm}{c^4 z} \omega^2 \left[ 2A^2 \cos 2\omega \left( t - \frac{z}{c} \right) + Al_0 \cos \omega \left( t - \frac{z}{c} \right) \right]. \end{aligned} \tag{14.50}$$

Thus, radiation emitted by the harmonic oscillator along the z-axis is *linearly polarized*. If, for instance, we consider two masses  $m = 10^3$  kg, with  $l_0 = 1$  m,  $A = 10^{-4}$  m, and  $\omega = 10^4$  rad/s, the term  $[2A^2 \cos 2\omega t]$  is negligible, and the dominant term is at the same frequency of the oscillations:

$$h^{\mathbf{T}\mathbf{T}}_{xx} \sim -\frac{2Gm}{c^4 z} \omega^2 A l_0 \cos \omega\left(t - \frac{z}{c}\right) \sim \frac{1.6 \cdot 10^{-35}}{z},$$

which is, as expected, very very small.

It should be noticed that due to the symmetry of the system, the wave emitted along y will be the same. To find the wave emitted along x, we choose  $\mathbf{n} = (1, 0, 0)$  and use the same procedure: no radiation will be found.

## 14.4 How to compute the energy carried by a gravitational wave

In order to evaluate how much energy is radiated in gravitational waves by an evolving system, we need to define a tensor that properly describes the energy content of the gravitational field. Our effort will not be completely successful, since we will be able to define a quantity which behaves like a tensor only under linear coordinate transformations. However, this pseudo-tensor will be useful for the purpose we have in mind.

### 14.4.1 The stress-energy pseudotensor of the gravitational field

In Chapter 7 we have shown that the stress-energy tensor of matter satisfies a divergenceless equation

$$T^{\mu\nu}{}_{;\nu} = 0. \quad (14.51)$$

If we choose a locally inertial frame (LIF), the covariant derivative reduces to the ordinary derivative and eq. (14.51) becomes

$$\frac{\partial T^{\mu\nu}}{\partial x^\nu} = 0. \quad (14.52)$$

We shall now try to find a quantity,  $\eta^{\mu\nu\gamma}$ , such that

$$T^{\mu\nu} = \frac{\partial}{\partial x^\gamma} \eta^{\mu\nu\gamma}; \quad (14.53)$$

In this way, if we impose that  $\eta^{\mu\nu\gamma}$  is **antisymmetric** in the indices  $\nu$  and  $\gamma$ , the conservation law (14.52) will automatically be satisfied.

The problem now is: can we find the explicit expression of  $\eta^{\mu\nu\gamma}$ ?

From Einstein's equations we know that

$$T^{\mu\nu} = \frac{c^4}{8\pi G} \left( R^{\mu\nu} - \frac{1}{2} g^{\mu\nu} R \right); \quad (14.54)$$

since we are in a locally inertial frame, the Riemann tensor, whose generic expression is

$$R_{\gamma\alpha\delta\beta} = \frac{1}{2} \left[ \frac{\partial^2 g_{\gamma\beta}}{\partial x^\alpha \partial x^\delta} + \frac{\partial^2 g_{\alpha\delta}}{\partial x^\gamma \partial x^\beta} - \frac{\partial^2 g_{\gamma\delta}}{\partial x^\alpha \partial x^\beta} - \frac{\partial^2 g_{\alpha\beta}}{\partial x^\gamma \partial x^\delta} \right] + g_{\sigma\rho} \left( \Gamma_{\alpha\delta}^\sigma \Gamma_{\gamma\beta}^\rho - \Gamma_{\alpha\beta}^\sigma \Gamma_{\gamma\delta}^\rho \right), \quad (14.55)$$

reduces to the term in square brackets since all  $\Gamma_{\alpha\delta}^\sigma$ 's vanish; it follows that in this frame the Ricci tensor becomes

$$\begin{aligned} R^{\mu\nu} &= g^{\mu\alpha} g^{\nu\beta} R_{\alpha\beta} = g^{\mu\alpha} g^{\nu\beta} g^{\gamma\delta} R_{\gamma\alpha\delta\beta} \\ &= \frac{1}{2} g^{\mu\alpha} g^{\nu\beta} g^{\gamma\delta} \left( \frac{\partial^2 g_{\gamma\beta}}{\partial x^\alpha \partial x^\delta} + \frac{\partial^2 g_{\alpha\delta}}{\partial x^\gamma \partial x^\beta} - \frac{\partial^2 g_{\gamma\delta}}{\partial x^\alpha \partial x^\beta} - \frac{\partial^2 g_{\alpha\beta}}{\partial x^\gamma \partial x^\delta} \right). \end{aligned} \quad (14.56)$$

By using this equation, after some cumbersome calculations eq. (14.54) becomes

$$T^{\mu\nu} = \frac{\partial}{\partial x^\alpha} \left\{ \frac{c^4}{16\pi G} \frac{1}{(-g)} \frac{\partial}{\partial x^\beta} \left[ (-g) \left( g^{\mu\nu} g^{\alpha\beta} - g^{\mu\alpha} g^{\nu\beta} \right) \right] \right\}. \quad (14.57)$$

The term in parentheses is antisymmetric in the indices  $\nu$  and  $\alpha$  and it is the quantity we were looking for:

$$\eta^{\mu\nu\alpha} = \frac{c^4}{16\pi G} \frac{1}{(-g)} \frac{\partial}{\partial x^\beta} \left[ (-g) \left( g^{\mu\nu} g^{\alpha\beta} - g^{\mu\alpha} g^{\nu\beta} \right) \right]. \quad (14.58)$$

If we now introduce the quantity

$$\zeta^{\mu\nu\alpha} = (-g) \eta^{\mu\nu\alpha} = \frac{c^4}{16\pi G} \frac{\partial}{\partial x^\beta} \left[ (-g) \left( g^{\mu\nu} g^{\alpha\beta} - g^{\mu\alpha} g^{\nu\beta} \right) \right], \quad (14.59)$$

since we are in a locally inertial frame  $\frac{\partial}{\partial x^\beta} \frac{1}{(-g)} = 0$ , therefore we can write eq. (14.57) as

$$\frac{\partial \zeta^{\mu\nu\alpha}}{\partial x^\alpha} = (-g) T^{\mu\nu}. \quad (14.60)$$

This equation has been derived in a LIF, where all first derivatives of the metric tensor vanish, but in any other frame this will not be true and the difference  $\frac{\partial \zeta^{\mu\nu\alpha}}{\partial x^\alpha} - (-g) T^{\mu\nu}$  will not be zero, but a quantity which we shall call  $(-g) t^{\mu\nu}$  i.e.

$$(-g) t^{\mu\nu} = \frac{\partial \zeta^{\mu\nu\alpha}}{\partial x^\alpha} - (-g) T^{\mu\nu}. \quad (14.61)$$

$t^{\mu\nu}$  is symmetric because both  $T^{\mu\nu}$  and  $\frac{\partial \zeta^{\mu\nu\alpha}}{\partial x^\alpha}$  are symmetric in  $\nu$  and  $\alpha$ . The explicit expression of  $t^{\mu\nu}$  can be found by substituting in eq. (14.61) the definition of  $\zeta^{\mu\nu\alpha}$  given in eq. (14.59), and  $T^{\mu\nu}$  computed in terms of the Ricci tensor from eq. (14.54) in an arbitrary frame (i.e. starting from the full expression of the Riemann tensor given in eq. 14.55): after some careful manipulation of the equations it is possible to show that

$$\begin{aligned} t^{\mu\nu} &= \frac{c^4}{16\pi G} \left\{ \left( 2\Gamma_{\alpha\beta}^\delta \Gamma_{\delta\sigma}^\sigma - \Gamma_{\alpha\sigma}^\delta \Gamma_{\beta\delta}^\sigma - \Gamma_{\alpha\delta}^\delta \Gamma_{\beta\sigma}^\sigma \right) \left( g^{\mu\alpha} g^{\nu\beta} - g^{\mu\nu} g^{\alpha\beta} \right) \right. \\ &+ g^{\mu\alpha} g^{\beta\delta} \left( \Gamma_{\alpha\sigma}^\nu \Gamma_{\beta\delta}^\sigma + \Gamma_{\beta\delta}^\nu \Gamma_{\alpha\sigma}^\sigma - \Gamma_{\delta\sigma}^\nu \Gamma_{\alpha\beta}^\sigma - \Gamma_{\alpha\beta}^\nu \Gamma_{\delta\sigma}^\sigma \right) \\ &+ g^{\nu\alpha} g^{\beta\delta} \left( \Gamma_{\alpha\sigma}^\mu \Gamma_{\beta\delta}^\sigma + \Gamma_{\beta\delta}^\mu \Gamma_{\alpha\sigma}^\sigma - \Gamma_{\delta\sigma}^\mu \Gamma_{\alpha\beta}^\sigma - \Gamma_{\alpha\beta}^\mu \Gamma_{\delta\sigma}^\sigma \right) \\ &\left. + g^{\alpha\beta} g^{\delta\sigma} \left( \Gamma_{\alpha\delta}^\mu \Gamma_{\beta\sigma}^\nu - \Gamma_{\alpha\beta}^\mu \Gamma_{\delta\sigma}^\nu \right) \right\} \end{aligned}$$

This is the stress-energy pseudotensor of the gravitational field we were looking for. Indeed we can rewrite eq. (14.61), valid in any reference frame, in the following form

$$(-g)(t^{\mu\nu} + T^{\mu\nu}) = \frac{\partial \zeta^{\mu\nu\alpha}}{\partial x^\alpha}, \quad (14.62)$$

and since  $\zeta^{\mu\nu\alpha}$  is antisymmetric in  $\mu$  and  $\alpha$

$$\frac{\partial}{\partial x^\mu} \frac{\partial \zeta^{\mu\nu\alpha}}{\partial x^\alpha} = 0,$$

and consequently

$$\frac{\partial}{\partial x^\mu} [(-g)(t^{\mu\nu} + T^{\mu\nu})] = 0. \quad (14.63)$$

This equation expresses a conservation law, because, as explained in chapter 7, it has the form of a vanishing ordinary divergence of the quantity  $[(-g)(t^{\mu\nu} + T^{\mu\nu})]$ . Since  $t^{\mu\nu}$  when added to the stress-energy tensor of matter (or fields) satisfies a conservation law, and since it vanishes only in a locally inertial frame where gravity is suppressed, we interpret  $t^{\mu\nu}$  as the entity that contains the information on the energy and momentum carried by the gravitational field. Thus eq. (14.63) expresses the conservation law of the total energy and momentum. Unfortunately,  $t^{\mu\nu}$  **is not a tensor**; indeed it is a combination of the  $\Gamma$ 's that are not tensors.

However, as the  $\Gamma$ 's, it behaves as a tensor under linear coordinate transformations.

#### 14.4.2 The energy flux carried by a gravitational wave

Let us consider an emitting source and the associated 3-dimensional coordinate frame  $O(x, y, z)$ . Be an observer located at  $P = (x_1, y_1, z_1)$  as shown in figure 14.1. Be  $r = \sqrt{x_1^2 + y_1^2 + z_1^2}$  its distance from the origin. The observer wants to detect the wave coming along the direction identified by the versor  $\mathbf{n} = \frac{\mathbf{r}}{|\mathbf{r}|}$ . As a pedagogical tool, let us consider a second frame  $O'(x', y', z')$ , with origin coincident with  $O$ , and having the  $x'$ -axis aligned with  $\mathbf{n}$ . Assuming that the wave traveling along  $x'$  direction is linearly polarized and has only one polarization, the corresponding metric tensor will be

$$g_{\mu'\nu'} = \begin{pmatrix} (ct) & (x') & (y') & (z') \\ -1 & 0 & 0 & 0 \\ 0 & 1 & 0 & 0 \\ 0 & 0 & [1 + h_+^{\mathbf{T}\mathbf{T}}(t, x')] & 0 \\ 0 & 0 & 0 & [1 - h_+^{\mathbf{T}\mathbf{T}}(t, x')] \end{pmatrix}.$$

The observer wants to measure the energy which flows per unit time across the unit surface orthogonal to  $x'$ , i.e.  $t^{0x'}$ , therefore he needs to compute the Christoffel symbols i.e. the derivatives of  $h_{\mu'\nu'}^{\mathbf{T}\mathbf{T}}$ . According to eq. (14.41) the metric perturbation has the form  $h^{\mathbf{T}\mathbf{T}}(t, x') = \frac{const}{x'} \cdot f(t - \frac{x'}{c})$ , and since the only derivatives which matter are those with respect to time and  $x'$

$$\frac{\partial h^{\mathbf{T}\mathbf{T}}}{\partial t} \equiv \dot{h}^{\mathbf{T}\mathbf{T}} = \frac{const}{x'} \dot{f},$$

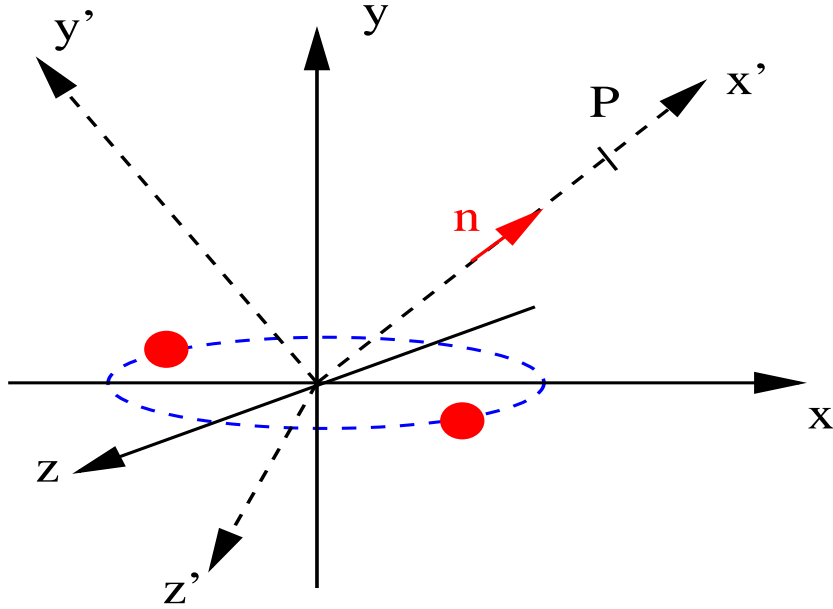

Figure 14.1: A binary system lies in the  $z$ - $x$  plane. An observer located at  $P$  wants to detect the energy flux of gravitational waves emitted by the system.

$$\frac{\partial h^{\mathbf{TT}}}{\partial x'} \equiv h^{\mathbf{TT}'} = -\frac{\text{const}}{x'^2} f + \frac{\text{const}}{x'} f' \sim -\frac{1}{c} \frac{\text{const}}{x'} \dot{f} = -\frac{1}{c} \dot{h}^{\mathbf{TT}},$$

where we have retained only the dominant  $1/x'$  term. Thus, the non-vanishing Christoffel symbols are:

$$\begin{aligned} \Gamma^0_{y'y'} = -\Gamma^0_{z'z'} = \frac{1}{2} \dot{h}_+^{\mathbf{TT}} & \quad \Gamma^{y'}_{0y'} = -\Gamma^{z'}_{0z'} = \frac{1}{2} \dot{h}_+^{\mathbf{TT}} & (14.64) \\ \Gamma^{x'}_{y'y'} = -\Gamma^{x'}_{z'z'} = \frac{1}{2c} \dot{h}_+^{\mathbf{TT}} & \quad \Gamma^{y'}_{y'x'} = -\Gamma^{z'}_{z'x'} = -\frac{1}{2c} \dot{h}_+^{\mathbf{TT}}. \end{aligned}$$

By substituting the Christoffel symbols in  $t^{\mu\nu}$  we find

$$ct^{0x'} = \frac{dE_{GW}}{dt dS} = \frac{c^3}{16\pi G} \left[ \left( \frac{dh^{\mathbf{TT}}(t, x')}{dt} \right)^2 \right].$$

If both polarizations are present

$$g_{\mu'\nu'} = \begin{pmatrix} (ct) & (x') & (y') & (z') \\ -1 & 0 & 0 & 0 \\ 0 & 1 & 0 & 0 \\ 0 & 0 & [1 + h_+^{\mathbf{TT}}(t, x')] & h_{\times}^{\mathbf{TT}}(t, x') \\ 0 & 0 & h_{\times}^{\mathbf{TT}}(t, x') & [1 - h_+^{\mathbf{TT}}(t, x')] \end{pmatrix},$$

and

$$\begin{aligned} ct^{0x'} &= \frac{dE_{GW}}{dtdS} = \frac{c^3}{16\pi G} \left[ \left( \frac{dh_+^{\mathbf{T}\mathbf{T}}(t, x')}{dt} \right)^2 + \left( \frac{dh_\times^{\mathbf{T}\mathbf{T}}(t, x')}{dt} \right)^2 \right] \\ &= \frac{c^3}{32\pi G} \left[ \sum_{jk} \left( \frac{dh_{jk}^{\mathbf{T}\mathbf{T}}(t, x')}{dt} \right)^2 \right]. \end{aligned} \quad (14.65)$$

This is the energy per unit time which flows across a unit surface orthogonal to the direction  $x'$ . However, the direction  $x'$  is arbitrary; if the observer is located in a different position and computes the energy flux he receives, he will find formally the same eq. (14.66) but with  $h_{jk}^{\mathbf{T}\mathbf{T}}$  referred to the  $\mathbf{T}\mathbf{T}$ -gauge associated with the new direction. Therefore, if we consider a generic direction  $\mathbf{r} = r\mathbf{n}$

$$t^{0r} = \frac{c^2}{32\pi G} \left[ \sum_{jk} \left( \frac{dh_{jk}^{\mathbf{T}\mathbf{T}}(t, r)}{dt} \right)^2 \right]. \quad (14.66)$$

In General Relativity the energy of the gravitational field cannot be defined locally, therefore to find the GW-flux we need to average over several wavelengths, i.e.

$$\frac{dE_{GW}}{dtdS} = \langle ct^{0r} \rangle = \frac{c^3}{32\pi G} \left\langle \sum_{jk} \left( \frac{dh_{jk}^{\mathbf{T}\mathbf{T}}(t, r)}{dt} \right)^2 \right\rangle.$$

Since

$$\begin{cases} \bar{h}^{\mathbf{T}\mathbf{T}}_{\mu 0} = 0, & \mu = 0, 3 \\ \bar{h}_{ik}^{\mathbf{T}\mathbf{T}}(t, r) = \frac{2G}{c^4 r} \cdot \left[ \frac{d^2}{dt^2} Q_{ik}^{\mathbf{T}\mathbf{T}} \left( t - \frac{r}{c} \right) \right] \end{cases}$$

by direct substitution we find

$$\frac{dE_{GW}}{dtdS} = \frac{G}{8\pi c^5 r^2} \left\langle \sum_{jk} \left( \ddot{Q}_{jk}^{\mathbf{T}\mathbf{T}} \left( t - \frac{r}{c} \right) \right)^2 \right\rangle. \quad (14.67)$$

If we now want to make explicit the dependence of the flux on the propagation direction  $\mathbf{n}$ , we can express  $Q_{jk}^{\mathbf{T}\mathbf{T}}$  in terms of the projector  $\mathcal{P}_{jkmn}$  as in eq. (14.45)

$$\frac{dE_{GW}}{dtdS} = \frac{G}{8\pi c^5 r^2} \left\langle \sum_{jk} \left( \mathcal{P}_{jkmn} \ddot{Q}_{mn} \left( t - \frac{r}{c} \right) \right)^2 \right\rangle. \quad (14.68)$$

From this formula we can now compute the gravitational luminosity  $L_{GW} = \frac{dE_{GW}}{dt}$ , i.e. the gravitational energy emitted by the source per unit time

$$\begin{aligned} L_{GW} &= \int \frac{dE_{GW}}{dtdS} dS = \int \frac{dE_{GW}}{dtdS} r^2 d\Omega \\ &= \frac{G}{2c^5} \frac{1}{4\pi} \int d\Omega \left\langle \sum_{jk} \left( \mathcal{P}_{jkmn} \ddot{Q}_{mn} \left( t - \frac{r}{c} \right) \right)^2 \right\rangle, \end{aligned} \quad (14.69)$$

where  $d\Omega = (d \cos \theta) d\phi$  is the solid angle element. This integral can be computed by using the properties of  $\mathcal{P}_{jkmn}$ :

$$\begin{aligned} \sum_{jk} \left( \mathcal{P}_{jkmn} \ddot{Q}_{mn} \right)^2 &= \sum_{jk} \mathcal{P}_{jkmn} \ddot{Q}_{mn} \mathcal{P}_{jkr s} \ddot{Q}_{rs} = \\ &= \left[ \sum_{jk} \mathcal{P}_{mnjk} \mathcal{P}_{jkr s} \right] \ddot{Q}_{mn} \ddot{Q}_{rs} = \mathcal{P}_{mnrs} \ddot{Q}_{mn} \ddot{Q}_{rs} \\ &= \left[ (\delta_{mr} - n_m n_r) (\delta_{ns} - n_n n_s) - \frac{1}{2} (\delta_{mn} - n_m n_n) (\delta_{rs} - n_r n_s) \right] \ddot{Q}_{mn} \ddot{Q}_{rs}. \end{aligned} \quad (14.70)$$

If we expand this expression, and remember that

- $\delta_{mn} \ddot{Q}_{mn} = \delta_{rs} \ddot{Q}_{rs} = 0$   
because the trace of  $Q_{ij}$  vanishes by definition, and
- $n_m n_r \delta_{ns} \ddot{Q}_{mn} \ddot{Q}_{rs} = n_n n_s \delta_{mr} \ddot{Q}_{mn} \ddot{Q}_{rs}$   
because  $Q_{ij}$  is symmetric,

at the end we find

$$\sum_{jk} \left( \mathcal{P}_{jkmn} \ddot{Q}_{mn} \right)^2 = \ddot{Q}_{rn} \ddot{Q}_{rn} - 2n_m \ddot{Q}_{ms} \ddot{Q}_{sr} n_r + \frac{1}{2} n_m n_n n_r n_s \ddot{Q}_{mn} \ddot{Q}_{rs}. \quad (14.71)$$

This expression has to be substituted in eq. (14.70), and the integrals to be performed over the solid angle are:

$$\frac{1}{4\pi} \int d\Omega n_i n_j, \quad \text{and} \quad \frac{1}{4\pi} \int d\Omega n_i n_j n_r n_s. \quad (14.72)$$

Let us compute the first.

In polar coordinates, the versor  $\mathbf{n}$  can be written as

$$n_i = (\sin \theta \cos \phi, \sin \theta \sin \phi, \cos \theta). \quad (14.73)$$

Thus, for parity reasons

$$\frac{1}{4\pi} \int d\Omega n_i n_j = 0 \quad \text{when } i \neq j. \quad (14.74)$$

Furthermore, since there is no preferred direction in the integration (isotropy), it must be

$$\int d\Omega n_1^2 = \int d\Omega n_2^2 = \int d\Omega n_3^2 \quad \rightarrow \quad \frac{1}{4\pi} \int d\Omega n_i n_j = \text{const} \cdot \delta_{ij}. \quad (14.75)$$

For instance,

$$\frac{1}{4\pi} \int d\Omega (n_3)^2 = \frac{1}{4\pi} \int d \cos \theta d\phi \cos^2 \theta = \frac{1}{4\pi} \int_0^{2\pi} d\phi \int_{-1}^1 d \cos \theta \cos^2 \theta = \frac{1}{3}, \quad (14.76)$$

and consequently

$$\frac{1}{4\pi} \int d\Omega n_i n_j = \frac{1}{3} \delta_{ij}. \quad (14.77)$$

The second integral in (14.72) can be computed in a similar way and gives

$$\frac{1}{4\pi} \int d\Omega n_i n_j n_r n_s = \frac{1}{15} (\delta_{ij} \delta_{rs} + \delta_{ir} \delta_{js} + \delta_{is} \delta_{jr}). \quad (14.78)$$

Consequently

$$\begin{aligned} \frac{1}{4\pi} \int d\Omega \left( \ddot{Q}_{rn} \ddot{Q}_{rn} - 2n_m \ddot{Q}_{ms} \ddot{Q}_{sr} n_r + \frac{1}{2} n_m n_n n_r n_s \ddot{Q}_{mn} \ddot{Q}_{rs} \right) \\ = \frac{2}{5} \ddot{Q}_{rn} \ddot{Q}_{rn} \end{aligned} \quad (14.79)$$

and, finally, the emitted power is

$$L_{GW} = \frac{G}{5c^5} \left\langle \sum_{k,n=1}^3 \ddot{Q}_{kn} \left( t - \frac{r}{c} \right) \ddot{Q}_{kn} \left( t - \frac{r}{c} \right) \right\rangle. \quad (14.80)$$

## 14.5 Gravitational radiation from a rotating star

In this section we shall show that a rotating star emits gravitational waves only if its shape deviates from axial symmetry.

Consider an ellipsoid of uniform density  $\rho$ . Its quadrupole moment is

$$q_{ij} = \int_V \rho x_i x_j dx^3, \quad i = 1, 3$$

and it is related to the inertia tensor

$$I_{ij} = \int_V \rho (r^2 \delta_{ij} - x_i x_j) dx^3$$

by the equation

$$q_{ij} = -I_{ij} + \delta_{ij} \text{Tr } q,$$

where  $\text{Tr } q \equiv q_m^m$ . Consequently, the reduced quadrupole moment can be written as

$$Q_{ij} = q_{ij} - \frac{1}{3} \delta_{ij} \text{Tr } q = - \left( I_{ij} - \frac{1}{3} \delta_{ij} \text{Tr } I \right).$$

Let us first consider a non rotating ellipsoid, with semiaxes  $a, b, c$ , volume  $V = \frac{4}{3} \pi abc$ , and equation:

$$\left( \frac{x_1}{a} \right)^2 + \left( \frac{x_2}{b} \right)^2 + \left( \frac{x_3}{c} \right)^2 = 1.$$

The inertia tensor is

$$I_{ij} = \frac{M}{5} \begin{pmatrix} b^2 + c^2 & 0 & 0 \\ 0 & c^2 + a^2 & 0 \\ 0 & 0 & a^2 + b^2 \end{pmatrix} = \begin{pmatrix} I_1 & 0 & 0 \\ 0 & I_2 & 0 \\ 0 & 0 & I_3 \end{pmatrix},$$

where  $I_1, I_2, I_3$  are the principal moments of inertia.

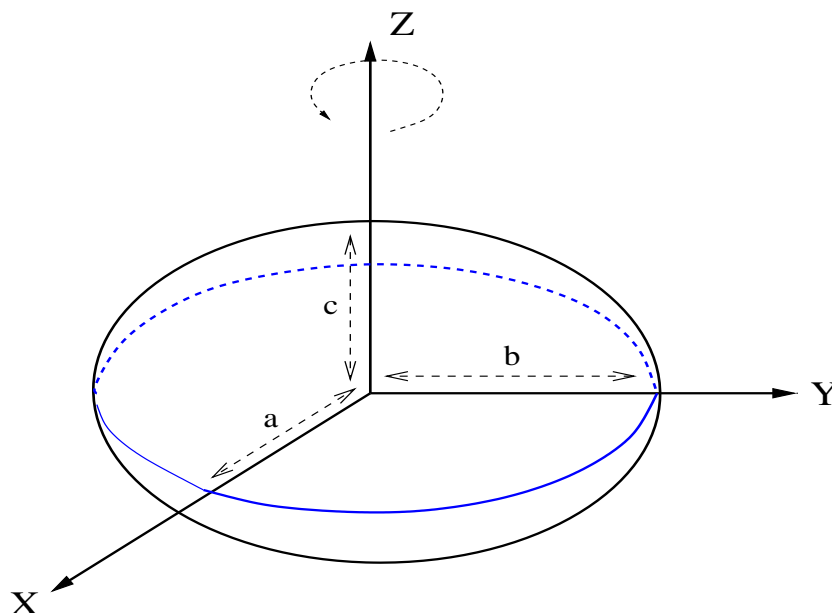

Let us now consider an ellipsoid which rotates around one of its principal axes, for instance  $I_3$ , with angular velocity  $(0, 0, \Omega)$ . What is its inertia tensor in this case?

Be  $\{x_i\}$  the coordinates of the inertial frame, and  $\{x'_i\}$  the coordinates of a co-rotating frame. Then,

$$x_i = R_{ij}x'_j,$$

where  $R_{ij}$  is the rotation matrix

$$R_{ij} = \begin{pmatrix} \cos \varphi & -\sin \varphi & 0 \\ \sin \varphi & \cos \varphi & 0 \\ 0 & 0 & 1 \end{pmatrix}, \quad \text{with } \varphi = \Omega t.$$

For instance, a point at rest in the co-rotating frame, with coordinates  $x'_i = (1, 0, 0)$ , has, in the inertial frame, coordinates  $x_i = (\cos \Omega t, \sin \Omega t, 0)$ , i.e. it rotates in the  $x-y$  plane with angular velocity  $\Omega$ .

Since in the co-rotating frame  $\{x'_i\}$

$$I'_{ij} = \begin{pmatrix} I_1 & 0 & 0 \\ 0 & I_2 & 0 \\ 0 & 0 & I_3 \end{pmatrix},$$

in the inertial frame  $\{x_i\}$  it will be

$$\begin{aligned} I_{ij} &= R_{ik}R_{jl}I'_{kl} = (RI'R^T)_{ij} \\ &= \begin{pmatrix} I_1 \cos^2 \varphi + I_2 \sin^2 \varphi & -\sin \varphi \cos \varphi (I_2 - I_1) & 0 \\ -\sin \varphi \cos \varphi (I_2 - I_1) & I_1 \sin^2 \varphi + I_2 \cos^2 \varphi & 0 \\ 0 & 0 & I_3 \end{pmatrix}. \end{aligned}$$

It is easy to check that  $\text{Tr } I = I_1 + I_2 + I_3 = \text{constant}$ .  
The quadrupole moment therefore is

$$Q_{ij} = - \left( I_{ij} - \frac{1}{3} \delta_{ij} \text{Tr } I \right) = -I_{ij} + \text{constant}$$

Using  $\cos 2\varphi = 2 \cos^2 \varphi - 1$ , etc., the quadrupole moment can be written as

$$Q_{ij} = \frac{I_2 - I_1}{2} \begin{pmatrix} \cos 2\varphi & \sin 2\varphi & 0 \\ \sin 2\varphi & -\cos 2\varphi & 0 \\ 0 & 0 & 0 \end{pmatrix} + \text{constant}$$

Since

$$I_1 = \frac{M}{5}(b^2 + c^2), \quad \text{and} \quad I_2 = \frac{M}{5}(c^2 + a^2),$$

if  $a, b$  are equal, the quadrupole moment is constant and **no gravitational wave is emitted**.

This is a generic result: an axisymmetric object rigidly rotating around its symmetry axis does not radiate gravitational waves.

In realistic cases,  $a \neq b$ , and  $I_1 \neq I_2$ ; however the difference is expected to be extremely small. It is convenient to express the quadrupole moment of the star in terms of a dimensionless parameter  $\epsilon$ , the *oblateness*, which expresses the deviation from axisymmetry

$$\epsilon \equiv \frac{a - b}{(a + b)/2}.$$

It is easy to show that

$$\frac{I_2 - I_1}{I_3} = \epsilon + O(\epsilon^3).$$

Indeed,

$$a - b = \frac{1}{2}\epsilon(a + b), \tag{14.81}$$

thus

$$\frac{I_2 - I_1}{I_3} = \frac{a^2 - b^2}{a^2 + b^2} = \frac{(a + b)(a - b)}{a^2 + b^2} = \frac{1}{2}\epsilon \frac{(a + b)^2}{a^2 + b^2}. \tag{14.82}$$

On the other hand, from (14.81) we have

$$(a - b)^2 = O(\epsilon^2) = a^2 + b^2 - 2ab, \tag{14.83}$$

therefore

$$2ab = a^2 + b^2 + O(\epsilon^2) \tag{14.84}$$

and

$$\frac{I_2 - I_1}{I_3} = \frac{1}{2}\epsilon \frac{a^2 + b^2 + 2ab}{a^2 + b^2} = \epsilon + O(\epsilon^3). \tag{14.85}$$

Consequently

$$Q_{ij} = \frac{\epsilon I_3}{2} \begin{pmatrix} \cos 2\varphi & \sin 2\varphi & 0 \\ \sin 2\varphi & -\cos 2\varphi & 0 \\ 0 & 0 & 0 \end{pmatrix} + \text{constant}. \quad (14.86)$$

Since  $\varphi = \Omega t$ , eq. (14.86) shows that GW are emitted at twice the rotation frequency. From eq. (14.41) and (14.45), the waveform is

$$h_{jk}^{\mathbf{TT}}(t, r) = \frac{2G}{rc^4} \mathcal{P}_{jklm} \left[ \frac{d^2}{dt^2} Q_{lm}(t - \frac{r}{c}) \right],$$

i.e., using eq. (14.86),

$$h_{ij}^{\mathbf{TT}} = h_0 \left[ \mathcal{P} \begin{pmatrix} -\cos 2\varphi_{ret} & -\sin 2\varphi_{ret} & 0 \\ -\sin 2\varphi_{ret} & \cos 2\varphi_{ret} & 0 \\ 0 & 0 & 0 \end{pmatrix} \right], \quad \varphi_{ret} = \Omega \left( t - \frac{r}{c} \right), \quad (14.87)$$

where

$$h_0 = \frac{4G \Omega^2}{c^4 r} I_3 \epsilon = \frac{16\pi^2 G}{c^4 r T^2} I_3 \epsilon, \quad (14.88)$$

where  $T$  is the rotation period and the term in square brackets in eq. (14.87) depends on the direction of the observer relative to the star axes. From eq. (14.87) we see that when the triaxial star rotates around a principal axis gravitational waves are emitted at twice the rotation frequency

$$\nu^{GW} = 2\nu_{rot}. \quad (14.89)$$

For fastly rotating neutron stars, the order of magnitude of the rotation period and of the moment of inertia is, respectively a few ms and  $\sim 10^{38} \text{Kg m}^2$ . The expected oblateness should be as small as  $\sim 10^{-6}$  and for a galactic source the distance from Earth is of a few kpc. Therefore, since

$$\frac{16\pi^2 G}{c^4} \cdot (1\text{ms})^{-2} \cdot (1\text{Kpc})^{-1} \cdot (10^{38} \text{Kg m}^2) \cdot (10^{-6}) = 4.21 \cdot 10^{-24},$$

the wave amplitude can be normalized as follows

$$h_0 = 4.21 \cdot 10^{-24} \left[ \frac{\text{ms}}{T} \right]^2 \left[ \frac{\text{Kpc}}{r} \right] \left[ \frac{I_3}{10^{38} \text{Kg m}^2} \right] \left[ \frac{\epsilon}{10^{-6}} \right].$$

This equation shows that the knowledge of  $\epsilon$  is important to estimate the wave amplitude. Astronomical observations allow to set an upper limit on this parameter by the following procedure. It is known that the rotational period of observed pulsars increases with time, i.e. pulsars slow down. This means that the system gradually loses its rotational energy, and this is due to several processes. For instance, since a pulsar has a time varying magnetic dipole moment it will radiate electromagnetic waves; moreover, as shown before, it may radiate gravitational waves.

Table 14.1: Upper limits of the oblateness for an ensemble of observed pulsars

name	$\nu_{GW}$ (Hz)	$\epsilon_{max}$
Vela	22	$1.8 \cdot 10^{-3}$
Crab	60	$7.5 \cdot 10^{-4}$
Geminga	8.4	$2.3 \cdot 10^{-3}$
PSR B 1509-68	13.2	$1.4 \cdot 10^{-2}$
PSR B 1706-44	20	$1.9 \cdot 10^{-3}$
PSR B 1957+20	1242	$1.6 \cdot 10^{-9}$
PSR J 0437-4715	348	$2.9 \cdot 10^{-8}$

Knowing the rate at which the period increases, we can estimate the amount of rotational energy which is lost in a given time interval; if we assume that the energy is entirely radiated in gravitational waves, from the expression of the gravitational luminosity given in eq. (14.80) and from eq. (14.86) we can estimate  $\epsilon$ . This will be an upper bound because we know that only part of the energy is dissipated in gravitational waves; thus  $\epsilon$  may be smaller than the value we would find.

This calculation has been done for a number of known pulsars (A. Giazotto, S. Bonazzola and E. Gourgoulhon, *On gravitational waves emitted by an ensemble of rotating neutron stars*, Phys. Rev. **D55**, 2014, 1997) and the results are shown in Table 14.1. As we said this is only an upper bound. Studies which take into account the maximum strain that the crust of a neutron star can support without breaking set a further constraint on  $\epsilon$

$$\epsilon \lesssim 5 \cdot 10^{-6}$$

(G. Ushomirsky, C. Cutler and L. Bildsten, *Deformations of accreting neutron star crusts and gravitational wave emission*, Mon. Not. Roy. Astron. Soc. **319**, 902, 2000). The first generation of interferometric gravitational antennas VIRGO and LIGO may be able to detect a wave emitted by a rotating neutron star if the amplitude is of the order  $h_0 \sim 10^{-24}$ ; therefore, given our present knowledge of the oblateness, it is reasonable to consider  $\epsilon$  as an unknown parameter which will hopefully be determined when gravitational waves from a rotating neutron star will be detected.

Let us now consider the case in which the star rotates about an axis which forms an angle with one of the principal axes, say,  $I_3$ . The angle between the two axes is called “wobble angle”. In this case, the angular velocity precesses around  $I_3$  (see figure 14.2). For simplicity, let us assume that  $I_3$  is a symmetry axis of the ellipsoid, i.e.

$$a = b \quad \rightarrow \quad I_1 = I_2,$$

and that the wobble angle  $\theta$  is small, i.e.  $\theta \ll 1$ . Be  $\{x'_i\}$  the coordinates of the co-rotating frame  $\mathbf{O}'$  and  $\{x_i\}$  those of the inertial frame  $\mathbf{O}$ . As usual  $x_i = R_{ij}x'_j$ , where  $R_{ij}$  is the rotation matrix.

The transformation from  $\mathbf{O}'$  to  $\mathbf{O}$  is the composition of two rotations:

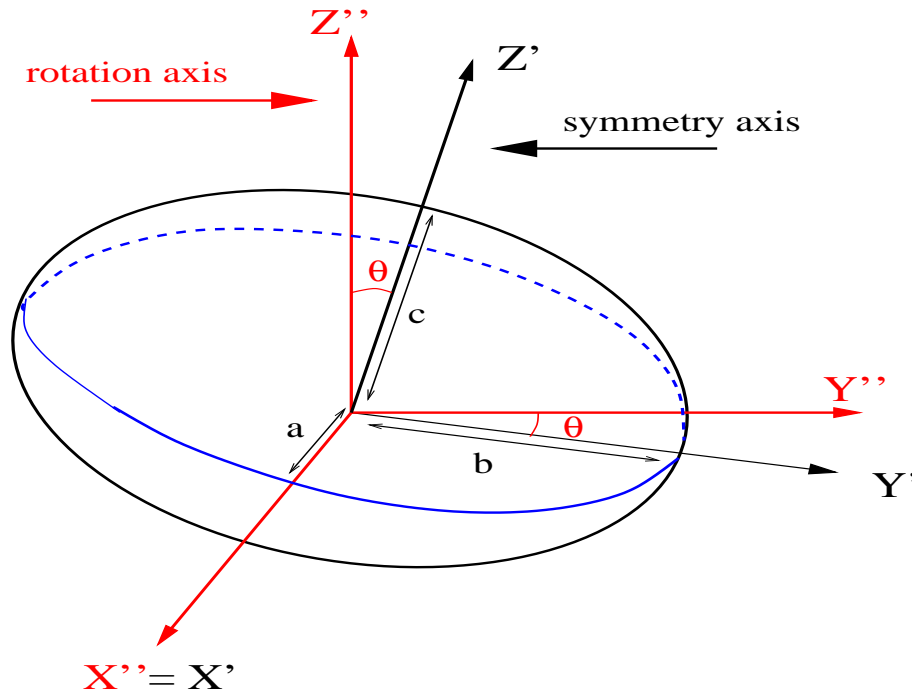
 Figure 14.2: From  $\mathbf{O}'$  to  $\mathbf{O}''$ 

- A rotation of  $\mathbf{O}'$  around the  $x'$  axis by a small angle  $\theta$  (constant); the new frame  $\mathbf{O}''$  has the  $z''$  axis coincident with the rotation axis. The corresponding rotation matrix is

$$R_x = \begin{pmatrix} 1 & 0 & 0 \\ 0 & \cos \theta & \sin \theta \\ 0 & -\sin \theta & \cos \theta \end{pmatrix} = \begin{pmatrix} 1 & 0 & 0 \\ 0 & 1 & \theta \\ 0 & -\theta & 1 \end{pmatrix} + O(\theta^2). \quad (14.90)$$

- A time dependent rotation around the  $z''$  axis, by an angle  $\varphi = \Omega t$ ; the corresponding rotation matrix is

$$R_z = \begin{pmatrix} \cos \varphi & -\sin \varphi & 0 \\ \sin \varphi & \cos \varphi & 0 \\ 0 & 0 & 1 \end{pmatrix}. \quad (14.91)$$

After this rotation, the symmetry axis of the ellipsoid precesses around the  $z$  axis, with angular velocity  $\Omega$ .

The rotation matrix from  $\mathbf{O}'$  to  $\mathbf{O}$  therefore is

$$\begin{aligned} R &= R_z R_x = \begin{pmatrix} \cos \varphi & -\sin \varphi & 0 \\ \sin \varphi & \cos \varphi & 0 \\ 0 & 0 & 1 \end{pmatrix} \begin{pmatrix} 1 & 0 & 0 \\ 0 & 1 & \theta \\ 0 & -\theta & 1 \end{pmatrix} + O(\theta^2) \\ &= \begin{pmatrix} \cos \varphi & -\sin \varphi & -\theta \sin \varphi \\ \sin \varphi & \cos \varphi & \theta \cos \varphi \\ 0 & -\theta & 1 \end{pmatrix} + O(\theta^2). \end{aligned} \quad (14.92)$$

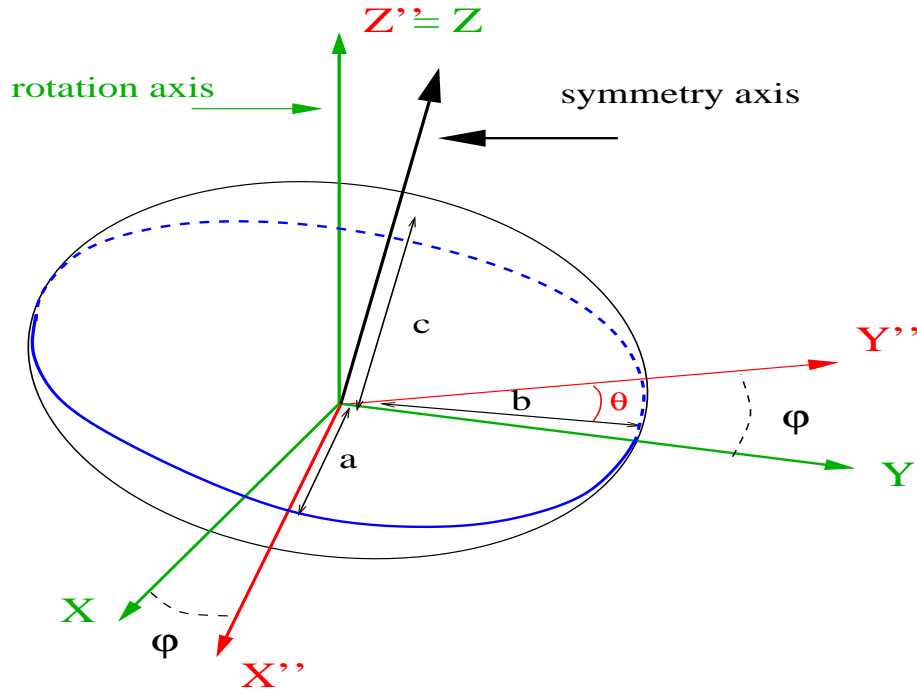
 Figure 14.3: From  $\mathbf{O}''$  to  $\mathbf{O}$ 

Since in the co-rotating frame  $\mathbf{O}'$

$$I'_{ij} = \begin{pmatrix} I_1 & 0 & 0 \\ 0 & I_1 & 0 \\ 0 & 0 & I_3 \end{pmatrix},$$

in the inertial frame  $\mathbf{O}$  it will be

$$I_{ij} = R_{ik} R_{jl} I'_{kl} = (R I' R^T)_{ij} \quad (14.93)$$

$$= \begin{pmatrix} I_1 & 0 & (I_1 - I_3)\theta \sin \varphi \\ 0 & I_1 & -(I_1 - I_3)\theta \cos \varphi \\ (I_1 - I_3)\theta \sin \varphi & -(I_1 - I_3)\theta \cos \varphi & I_3 \end{pmatrix} + O(\theta^2). \quad (14.94)$$

The quadrupole moment can then be written as

$$Q_{ij} = -I_{ij} + \text{const.} = (I_1 - I_3) \theta \begin{pmatrix} 0 & 0 & -\sin \varphi \\ 0 & 0 & \cos \varphi \\ -\sin \varphi & \cos \varphi & 0 \end{pmatrix} + \text{const.} + O(\theta^2), \quad (14.95)$$

and the wave amplitude therefore is

$$h_{jk}^{\text{TT}}(t, r) = \frac{2G}{rc^4} \mathcal{P}_{jklm} \left[ \frac{d^2}{dt^2} Q^{lm} \left( t - \frac{r}{c} \right) \right],$$

i.e., using eq. (14.95),

$$h_{ij}^{\mathbf{TT}} = h_0 \left[ \mathcal{P} \begin{pmatrix} 0 & 0 & \sin \varphi_{ret} \\ 0 & 0 & -\cos \varphi_{ret} \\ \sin \varphi_{ret} & -\cos \varphi_{ret} & 0 \end{pmatrix} \right], \quad \varphi_{ret} = \Omega \left( t - \frac{r}{c} \right), \quad (14.96)$$

where

$$h_0 = \frac{2G \Omega^2}{c^4 r} (I_1 - I_3) \theta = \frac{8\pi^2 G}{c^4 r T^2} (I_1 - I_3) \theta. \quad (14.97)$$

From eq. (14.96) we see that when the triaxial star rotates around an axis which does not coincide with a principal axis gravitational waves are emitted at the rotation frequency

$$\nu^{GW} = \nu_{rot}.$$

As the oblateness, the wobble angle is an unknown parameter.

## 14.6 Gravitational wave emitted by a binary system in circular orbit

We shall now estimate the gravitational signal emitted by a binary system composed of two stars moving on a circular orbit around their common center of mass. For simplicity we shall assume that the two stars of mass  $m_1$  and  $m_2$  are point masses. Be  $l_0$  the orbital separation,  $M$  the *total mass*

$$M \equiv m_1 + m_2, \quad (14.98)$$

and  $\mu$  the *reduced mass*

$$\mu \equiv \frac{m_1 m_2}{M}. \quad (14.99)$$

Let us consider a coordinate frame with origin coincident with the center of mass of the system as indicated in figure (14.4) and be

$$l_0 = r_1 + r_2, \quad r_1 = \frac{m_2 l_0}{M}, \quad r_2 = \frac{m_1 l_0}{M}. \quad (14.100)$$

The orbital frequency can be found from Kepler's law

$$G \frac{m_1 m_2}{l_0^2} = m_1 \omega_K^2 \frac{m_2 l_0}{M}, \quad G \frac{m_1 m_2}{l_0^2} = m_2 \omega_K^2 \frac{m_1 l_0}{M},$$

from which we find

$$\omega_K = \sqrt{\frac{GM}{l_0^3}} \quad (14.101)$$

is the Keplerian frequency. Be  $(x_1, x_2)$  and  $(y_1, y_2)$  the coordinates of the masses  $m_1$  and  $m_2$  on the orbital plane

$$\begin{aligned} x_1 &= \frac{m_2}{M} l_0 \cos \omega_K t & x_2 &= -\frac{m_1}{M} l_0 \cos \omega_K t \\ y_1 &= \frac{m_2}{M} l_0 \sin \omega_K t & y_2 &= -\frac{m_1}{M} l_0 \sin \omega_K t. \end{aligned} \quad (14.102)$$

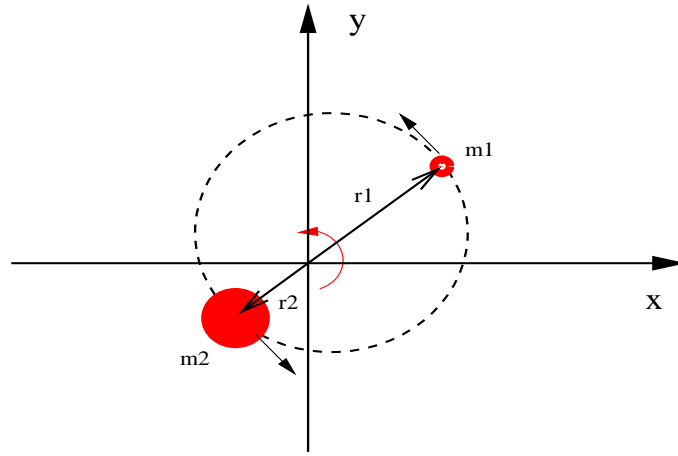

Figure 14.4: Two point masses in circular orbit around the common center of mass

The 00-component of the stress-energy tensor of the system is

$$T^{00} = c^2 \sum_{n=1}^2 m_n \delta(x - x_n) \delta(y - y_n) \delta(z),$$

and the non vanishing components of the quadrupole moment are

$$\begin{aligned} q_{xx} &= m_1 \int_V x^2 \delta(x - x_1) dx \delta(y - y_1) dy \delta(z) dz \\ &+ m_2 \int_V x^2 \delta(x - x_2) dx \delta(y - y_2) dy \delta(z) dz = m_1 x_1^2 + m_2 x_2^2 \\ &= \mu l_0^2 \cos^2 \omega_K t = \frac{\mu}{2} l_0^2 \cos 2\omega_K t + \text{cost}, \end{aligned}$$

$$\begin{aligned} q_{yy} &= m_1 \int_V \delta(x - x_1) dx y^2 \delta(y - y_1) dy \delta(z) dz \\ &+ m_2 \int_V \delta(x - x_2) dx y^2 \delta(y - y_2) dy \delta(z) dz = m_1 y_1^2 + m_2 y_2^2 \\ &= \mu l_0^2 \sin^2 \omega_K t = -\frac{\mu}{2} l_0^2 \cos 2\omega_K t + \text{cost}1, \end{aligned}$$

and

$$\begin{aligned} q_{xy} &= m_1 \int_V x \delta(x - x_1) dx y \delta(y - y_1) dy \delta(z) dz \\ &+ m_2 \int_V x \delta(x - x_2) dx y \delta(y - y_2) dy \delta(z) dz \\ &= m_1 x_1 y_1 + m_2 x_2 y_2 = \mu l_0^2 \cos \omega t \sin \omega_K t = \frac{\mu}{2} l_0^2 \sin 2\omega_K t. \end{aligned}$$

(we have used  $\cos 2\alpha = 2 \cos^2 \alpha - 1$ ,  $\sin^2 \alpha = \frac{1}{2} - \frac{1}{2} \cos 2\alpha$  and  $m_1 m_2 = \mu M$ );  
In summary

$$q_{xx} = \frac{\mu}{2} l_0^2 \cos 2\omega_K t + \text{cost}$$

$$\begin{aligned} q_{yy} &= -\frac{\mu}{2} l_0^2 \cos 2\omega_K t + \text{const} \\ q_{xy} &= \frac{\mu}{2} l_0^2 \sin 2\omega_K t, \end{aligned}$$

and

$$q^k{}_k = \eta^{kl} q_{kl} = q_{xx} + q_{yy} = \text{constant}.$$

The time-varying part of  $Q_{ij} = q_{ij} - \frac{1}{3} \delta_{ij} q^k{}_k$  therefore is:

$$\begin{aligned} Q_{xx} &= -Q_{yy} = \frac{\mu}{2} l_0^2 \cos 2\omega_K t \\ Q_{xy} &= \frac{\mu}{2} l_0^2 \sin 2\omega_K t, \end{aligned} \tag{14.103}$$

and defining a matrix  $A_{ij}$

$$A_{ij}(t) = \begin{pmatrix} \cos 2\omega_K t & \sin 2\omega_K t & 0 \\ \sin 2\omega_K t & -\cos 2\omega_K t & 0 \\ 0 & 0 & 0 \end{pmatrix} \tag{14.104}$$

we can write

$$Q_{ij} = \frac{\mu}{2} l_0^2 A_{ij}. \tag{14.105}$$

Since the wave emitted along a generic direction  $\mathbf{n}$  in the  $\mathbf{TT}$ -gauge is

$$h_{ij}^{\mathbf{TT}}(t, r) = \frac{2G}{rc^4} \frac{d^2}{dt^2} \left[ Q_{ij}^{\mathbf{TT}}(t - \frac{r}{c}) \right] \quad \text{where} \quad Q_{ij}^{\mathbf{TT}}(t - \frac{r}{c}) = \mathcal{P}_{ijkl} Q_{kl}(t - \frac{r}{c})$$

using eq. (14.101) we find

$$h_{ij}^{\mathbf{TT}} = -\frac{2G}{rc^4} \frac{\mu}{2} l_0^2 (2\omega_K)^2 [\mathcal{P}_{ijkl} A_{kl}] = -\frac{4 \mu M G^2}{r l_0 c^4} [\mathcal{P}_{ijkl} A_{kl}]. \tag{14.106}$$

By defining a wave amplitude

$$h_0 = \frac{4 \mu M G^2}{r l_0 c^4} \tag{14.107}$$

we can finally write the emitted wave as

$$h_{ij}^{\mathbf{TT}}(t, r) = -h_0 A_{ij}^{\mathbf{TT}}(t - \frac{r}{c}), \tag{14.108}$$

where

$$A_{ij}^{\mathbf{TT}}(t - \frac{r}{c}) = \left[ \mathcal{P}_{ijkl} A_{kl}(t - \frac{r}{c}) \right] \tag{14.109}$$

depends on the orientation of the line of sight with respect to the orbital plane.

From these equations we see that the radiation is emitted at **twice the orbital frequency**.

For example, if  $\mathbf{n} = \mathbf{z}$ ,  $P_{ij} = \text{diag}(1, 1, 0)$

$$A_{ij}^{\mathbf{TT}}(t) = \begin{pmatrix} \cos 2\omega_K t & \sin 2\omega_K t & 0 \\ \sin 2\omega_K t & -\cos 2\omega_K t & 0 \\ 0 & 0 & 0 \end{pmatrix} \tag{14.110}$$

and

$$\begin{aligned} h^{\mathbf{TT}}_{xx} &= -h^{\mathbf{TT}}_{yy} = -h_0 \cos 2\omega_K \left(t - \frac{z}{c}\right) \\ h^{\mathbf{TT}}_{xy} &= -h_0 \sin 2\omega_K \left(t - \frac{z}{c}\right). \end{aligned} \quad (14.111)$$

In this case the wave has both polarizations, and since  $h^{\mathbf{TT}}_{xx} = h_0 \Re \left\{ e^{i\omega \left(t - \frac{z}{c}\right)} \right\}$  and  $h^{\mathbf{TT}}_{xy} = h_0 \Im \left\{ e^{i\omega \left(t - \frac{z}{c}\right)} \right\}$ , the wave is circularly polarized.

If  $\mathbf{n} = \mathbf{x}$ ,  $P_{ij} = \text{diag}(0, 1, 1)$

$$A_{ij}^{\mathbf{TT}} = \begin{pmatrix} 0 & 0 & 0 \\ 0 & -\frac{1}{2} \cos 2\omega_K t & 0 \\ 0 & 0 & \frac{1}{2} \cos 2\omega_K t \end{pmatrix} \quad (14.112)$$

and

$$h^{\mathbf{TT}}_{yy} = -h^{\mathbf{TT}}_{zz} = +\frac{1}{2} h_0 \cos 2\omega_K \left(t - \frac{x}{c}\right), \quad (14.113)$$

i.e. the wave is a linearly polarized wave.

If  $\mathbf{n} = \mathbf{y}$ ,  $P_{ij} = \text{diag}(1, 0, 1)$  and

$$A_{ij}^{\mathbf{TT}} = \begin{pmatrix} \frac{1}{2} \cos 2\omega_K t & 0 & 0 \\ 0 & 0 & 0 \\ 0 & 0 & -\frac{1}{2} \cos 2\omega_K t \end{pmatrix} \quad (14.114)$$

and again the wave is linearly polarized

$$h^{\mathbf{TT}}_{xx} = -h^{\mathbf{TT}}_{zz} = -\frac{1}{2} h_0 \cos 2\omega_K \left(t - \frac{y}{c}\right). \quad (14.115)$$

Eqs. (14.107) can be used to estimate the amplitude of the gravitational signal emitted by the binary system PSR 1931+16 discovered in 1975, (R.A. Hulse and J.H. Taylor, *Discovery Of A Pulsar In A Binary System*, *Astrophys. J.* **195**, L51, 1975) which consists of two neutron stars orbiting at a very short distance from each other. The data we know from observations are:

$$\begin{aligned} m_1 \sim m_2 \sim 1.4 M_\odot, \quad l_0 = 0.19 \cdot 10^{12} \text{ cm} \\ T = 7 \text{ h } 45 \text{ m } 7 \text{ s}, \quad \nu_K = \frac{\omega_K}{2\pi} \sim 3.58 \cdot 10^{-5} \text{ Hz} \end{aligned} \quad (14.116)$$

where  $T$  is the orbital period. Note that the two stars have nearly equal masses: they are comparable to that of the Sun, and their orbital separation is about twice the radius of the Sun! The orbit is eccentric with eccentricity  $\epsilon \simeq 0.617$ , however we shall assume it is circular and apply eqs. (14.107). For this system the emission frequency is

$$\nu_{GW} = 2\nu_K \sim 7.16 \cdot 10^{-5} \text{ Hz}, \quad (14.117)$$

therefore the wavelength of the emitted radiation is

$$\lambda_{GW} = \frac{c}{\nu_{GW}} \sim 10^{14} \text{ cm} \quad \text{i.e.} \quad \lambda_{GW} \gg l_0. \quad (14.118)$$

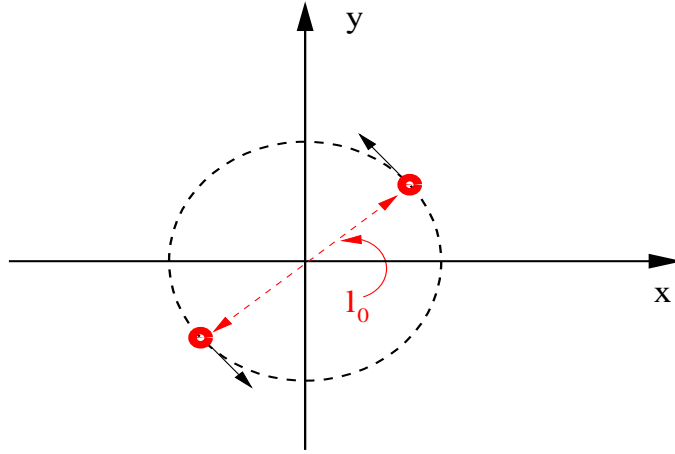

Figure 14.5: Two equal point masses in circular orbit

Thus, the slow-motion approximation, on which the quadrupole formalism is based, is certainly satisfied in this case even though the two neutron stars are orbiting at such small distance from each other. The distance of the system from Earth is  $r = 5 \text{ kpc}$ , and since

$$1 \text{ pc} = 3.08 \cdot 10^{18} \text{ cm}, \quad \rightarrow \quad r = 1.5 \cdot 10^{22} \text{ cm}.$$

The wave amplitude is

$$h_0 = \frac{4 \mu M G^2}{r l_0 c^4} \sim 5 \cdot 10^{-23}.$$

A new binary pulsar has recently been discovered (M. Burgay *et al.*, *An increased estimate of the merger rate of double neutron stars from observations of a highly relativistic system* Nature **426**, 531, 2003) which has an even shorter orbital period and it is closer than PSR 1931+16: it is the double pulsar PSR J0737-3039, whose orbital parameters are

$$\begin{aligned} m_1 &= 1.337 M_\odot, & m_2 &\sim 1.250 M_\odot \\ T &= 2.4 \text{ h}, & e &= 0.08 \\ r &= 500 \text{ pc} & l_0 &\sim 1.2 R_\odot. \end{aligned}$$

In this case the orbit is nearly circular,

$$\mu = \frac{m_1 m_2}{m_1 + m_2} = 0.646 M_\odot \quad \rightarrow \quad h_0 = \frac{4 \mu M G^2}{r l_0 c^4} \sim 1.1 \cdot 10^{-21},$$

and waves are emitted at the frequency

$$\nu_{GW} = 2 \nu_K = 2.3 \cdot 10^{-4} \text{ Hz}.$$

In this section we have considered only circular orbits; the calculations can be generalized to the case of eccentric or open orbits by replacing the equation of motion of the two masses

(14.102) by those appropriate to the chosen orbit. By this procedure it is possible to show that when the orbits are ellipses, gravitational waves are emitted at frequencies multiple of the orbital frequency  $\nu_K$ , and that the number of equally spaced spectral lines increases with the eccentricity.

## 14.7 Evolution of a binary system due to the emission of gravitational waves

In this section we shall show that the orbital period  $T$  of a binary system decreases in time due to gravitational wave emission.  $\dot{T} \equiv dT/dt$  has indeed been measured for PSR 1931+16, and the observations are in very good agreement with the predictions of General Relativity, providing a first indirect proof of the existence of gravitational waves. The orbital evolution driven by gravitational wave emission quietly proceeds bringing the stars closer. As their distance decreases, the process becomes faster and the two stars spiral toward their common center of mass until they coalesce.

We shall now describe how the binary system evolves, explicitly computing  $\dot{T}$  and the emitted signal up to the point when the quadrupole approximation is violated and the theory developed in this chapter can no longer be applied.

We shall start by computing the gravitational luminosity defined in eq. (14.103); using the reduced quadrupole moment of a binary system given by eqs. (14.104) and (14.105) we find

$$\sum_{k,n=1}^3 \ddot{Q}_{kn} \ddot{Q}_{kn} = 32 \mu^2 l_0^4 \omega_K^6 = 32 \mu^2 G^3 \frac{M^3}{l_0^5}.$$

and by direct substitution in eq. (14.80)

$$L_{GW} \equiv \frac{dE_{GW}}{dt} = \frac{32}{5} \frac{G^4}{c^5} \frac{\mu^2 M^3}{l_0^5}. \quad (14.119)$$

This expression has to be considered as an average over several wavelengths (or equivalently, over a sufficiently large number of periods), as stated in eq. (14.80); therefore, in order  $L_{GW}$  to be defined, we must be in a regime where the orbital parameters do not change significantly over the time interval taken to perform the average. This assumption is called *adiabatic approximation*, and it is certainly applicable to systems like PSR 1931+16 or PSR J0737-3039 that are very far from coalescence. In the adiabatic regime, the system has the time to adjust the orbit to compensate the energy lost in gravitational waves with a change in the orbital energy, in such a way that

$$\frac{dE_{orb}}{dt} + L_{GW} = 0. \quad (14.120)$$

Let us see what are the consequences of this equation. The orbital energy is

$$E_{orb} = E_K + U$$

where the kinetic and the gravitational energy are, respectively,

$$\begin{aligned} E_K &= \frac{1}{2}m_1\omega_K^2 r_1^2 + \frac{1}{2}m_2\omega_K^2 r_2^2 \\ &= \frac{1}{2}\omega_K^2 \left[ \frac{m_1m_2^2l_0^2}{M^2} + \frac{m_2m_1^2l_0^2}{M^2} \right] \\ &= \frac{1}{2}\omega_K^2\mu l_0^2 = \frac{1}{2}\frac{G\mu M}{l_0} \end{aligned}$$

and

$$U = -\frac{Gm_1m_2}{l_0} = -\frac{G\mu M}{l_0}.$$

Therefore

$$E_{orb} = -\frac{1}{2}\frac{G\mu M}{l_0} \quad (14.121)$$

and its time derivative is

$$\frac{dE_{orb}}{dt} = \frac{1}{2}\frac{G\mu M}{l_0} \left( \frac{1}{l_0} \frac{dl_0}{dt} \right) = -E_{orb} \left( \frac{1}{l_0} \frac{dl_0}{dt} \right). \quad (14.122)$$

The term  $\frac{dl_0}{dt}$  can be expressed in terms of the time derivative of  $\omega_K$  as follows

$$\omega_K^2 = GMl_0^{-3} \rightarrow 2 \ln \omega_K = \ln GM - 3 \ln l_0 \rightarrow \frac{1}{\omega_K} \frac{d\omega_K}{dt} = -\frac{3}{2} \frac{1}{l_0} \frac{dl_0}{dt},$$

and eq. (14.122) becomes

$$\frac{dE_{orb}}{dt} = \frac{2}{3} \frac{E_{orb}}{\omega_K} \frac{d\omega_K}{dt}. \quad (14.123)$$

Since  $\omega_K = 2\pi P^{-1}$

$$\frac{1}{\omega_K} \frac{d\omega_K}{dt} = -\frac{1}{P} \frac{dP}{dt}$$

and eq. (14.123) gives

$$\frac{dE_{orb}}{dt} = -\frac{2}{3} \frac{E_{orb}}{P} \frac{dP}{dt} \rightarrow \frac{dT}{dt} = -\frac{3}{2} \frac{P}{E_{orb}} \frac{dE_{orb}}{dt}. \quad (14.124)$$

Since by eq. (14.120)  $\frac{dE_{orb}}{dt} = -L_{GW}$  we finally find how the orbital period changes due to the emission of gravitational waves

$$\frac{dP}{dt} = \frac{3}{2} \frac{P}{E_{orb}} L_{GW}. \quad (14.125)$$

For example if we consider PSR 1931+16, assuming the orbit is circular we find

$$P = 27907 \text{ s}, \quad E_{orb} \sim -1.4 \cdot 10^{48} \text{ erg}, \quad L_{GW} \sim 0.7 \cdot 10^{31} \text{ erg/s} \quad (14.126)$$

and

$$\frac{dP}{dt} \sim -2.2 \cdot 10^{-13}.$$

As mentioned in section 14.6, the orbit of the real system has a quite strong eccentricity  $\epsilon \simeq 0.617$ . By doing the calculation using the equations of motion appropriate for an eccentric orbit we would find

$$\frac{dP}{dt} = -2.4 \cdot 10^{-12}.$$

PSR 1931+16 has now been monitored for decades and the rate of variation of the period, measured with very high accuracy, is

$$\frac{dP}{dt} = -(2.4184 \pm 0.0009) \cdot 10^{-12}.$$

(J. M. Wisberg, J.H. Taylor *Relativistic Binary Pulsar B1913+16: Thirty Years of Observations and Analysis*, in Binary Radio Pulsars, ASP Conference series, 2004, eds. F.AA.Rasio, I.H.Stairs). Thus, the prediction of General Relativity are confirmed by observations. This result provided the first indirect evidence of the existence of gravitational waves and for this discovery Hulse and Taylor have been awarded of the Nobel prize in 1993.

For the recently discovered double pulsar PSR J0737-3039

$$P = 8640 \text{ s}, \quad E_{orb} \sim -2.55 \cdot 10^{48} \text{ erg/s}, \quad L_{GW} \sim 2.24 \cdot 10^{32} \text{ erg/s} \quad (14.127)$$

and

$$\frac{dP}{dt} \sim -1.2 \cdot 10^{-12}.$$

Knowing the energy lost by the system, we can also evaluate how the orbital separation  $l_0$  changes in time. From eq. (14.122) and remembering that  $\frac{dE_{orb}}{dt} = -L_{GW}$  we find

$$\frac{1}{l_0} \frac{dl_0}{dt} = \frac{L_{GW}}{E_{orb}} = - \left[ \frac{64}{5} \frac{G^3}{c^5} \mu M^2 \right] \cdot \frac{1}{l_0^4} \quad (14.128)$$

Assuming that at some initial time  $t = 0$  the orbital separation is  $l_0(t = 0) = l_0^{in}$  by integrating eq. (14.128) we easily find

$$l_0^4(t) = (l_0^{in})^4 - \frac{256}{5} \frac{G^3}{c^5} \mu M^2 t. \quad (14.129)$$

If we define

$$t_{coal} = \frac{5}{256} \frac{c^5}{G^3} \frac{(l_0^{in})^4}{\mu M^2}, \quad (14.130)$$

eq. (14.129) can be written as

$$l_0(t) = l_0^{in} \left[ 1 - \frac{t}{t_{coal}} \right]^{1/4}. \quad (14.131)$$

From this equation we see that when  $t = t_{coal}$  the orbital separation becomes zero, and this is possible because we have assumed that the bodies composing the binary system are pointlike. Of course, stars and black holes have finite sizes, therefore they start merging and coalesce before  $t = t_{coal}$  is reached. In addition, when the two stars are close enough both the slow motion approximation and the weak field assumption on which the quadrupole formalism relies fails to hold and strong field effects have to be considered; however, the value of  $t_{coal}$  gives an indication of the time the system needs to merge starting from a given initial distance  $l_0^{in}$ .

### 14.7.1 The emitted waveform

Since in the adiabatic regime the orbit evolves through a sequence of stationary circular orbits, using eq. (14.131) we can compute how  $\omega_K$  changes in time

$$\omega_K(t) = \sqrt{\frac{GM}{l_0^3}} = \omega_K^{in} \left[1 - \frac{t}{t_{coal}}\right]^{-3/8}, \quad \omega_K^{in} = \sqrt{\frac{GM}{(l_0^{in})^3}}. \quad (14.132)$$

Consequently, the frequency of the emitted wave at some time  $t$  will be twice the orbital frequency at the same time, i.e.

$$\nu_{GW}(t) = \frac{\omega_K}{\pi} = \nu_{GW}^{in} \left[1 - \frac{t}{t_{coal}}\right]^{-3/8}, \quad \nu_{GW}^{in} = \frac{1}{\pi} \sqrt{\frac{GM}{(l_0^{in})^3}}. \quad (14.133)$$

Similarly, the instantaneous amplitude of the emitted signal can be found from eq. (14.107)

$$h_0(t) = \frac{4\mu MG^2}{rl_0(t)c^4} = \frac{4\mu MG^2}{rc^4} \cdot \frac{\omega_K^{2/3}(t)}{G^{1/3}M^{1/3}} \quad (14.134)$$

$$= \frac{4\pi^{2/3} G^{5/3} \mathcal{M}^{5/3}}{c^4 r} \nu_{GW}^{2/3}(t) \quad (14.135)$$

where

$$\mathcal{M}^{5/3} = \mu M^{2/3} \quad \rightarrow \quad \mathcal{M} = \mu^{3/5} M^{2/5} \quad (14.136)$$

Eqs. (14.133) and (14.136) show that the amplitude and the frequency of the gravitational signal emitted by a coalescing system increases with time. For this reason this peculiar waveform is called *chirp*, like the chirp of a singing bird, and  $\mathcal{M}$  is said **chirp mass**. According to eq. (14.108) the emitted waveform is

$$h_{ij}^{\mathbf{T}\mathbf{T}}(t, r) = h_0 \left[ \mathcal{P}_{ijkl} A_{kl} \left( t - \frac{r}{c} \right) \right] \quad (14.137)$$

where  $A_{kl}$  is given in eq. (14.104). Since  $\omega_K$  changes in time as in eq. (14.132), the phase appearing in  $A_{kl}$  has to be substituted by an integrated phase

$$\Phi(t) = \int^t 2\omega_K(t) dt = \int^t 2\pi\nu_{GW}(t) dt + \Phi_{in}, \quad \text{where } \Phi_{in} = \Phi(t=0)$$

Since

$$\nu_{in} t_{coal}^{3/8} = \left(5^{3/8}\right) \frac{1}{8\pi} \left(\frac{c^3}{GM}\right)^{5/8}$$

then

$$\nu_{GW}(t) = \frac{1}{8\pi} \left(\frac{c^3}{GM}\right)^{5/8} \left[\frac{5}{t_{coal} - t}\right]^{3/8}$$

and the integrated phase becomes

$$\Phi(t) = -2 \left[ \frac{c^3 (t_{coal} - t)}{5GM} \right]^{5/8} + \Phi_{in}$$

which shows that if we know the phase we can measure the chirp mass. In conclusion, the signal emitted during the inspiralling will be

$$h_{ij}^{\mathbf{TT}} = -\frac{4\pi^{2/3} G^{5/3} \mathcal{M}^{5/3}}{c^4 r} \nu_{GW}^{2/3}(t) \left[ \mathcal{P}_{ijkl} A_{kl}(t - \frac{r}{c}) \right]$$

where

$$A_{ij}(t) = \begin{pmatrix} \cos \Phi(t) & \sin \Phi(t) & 0 \\ \sin \Phi(t) & -\cos \Phi(t) & 0 \\ 0 & 0 & 0 \end{pmatrix}$$