

# Laser noise measurement

Antonino Chiummo – INFN Na

24/11/25

Fisica della Gravitazione Sperimentale

[antonino.Chiummo@na.infn.it](mailto:antonino.Chiummo@na.infn.it) – room 1G22a

# Laser relative intensity noise measurement

## Context: LAG & LAG-M

The **Liquid Actuated Gravity (LAG)** experiment is a real and innovative R&D project by the Italian National Institute for Nuclear Physics (INFN), primarily investigating precise gravitational measurements using a novel liquid-based field mass.

LAG uses a container whose liquid level is varied to modulate the gravitational field acting on a nearby test mass (suspended as a torsion pendulum). By pumping liquid in and out, the gravitational pull can be changed rhythmically—**without moving massive solid parts** near the sensitive mass—allowing precise, low-frequency modulation and coherent signal detection

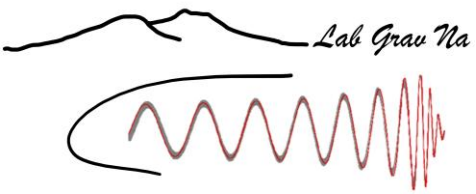
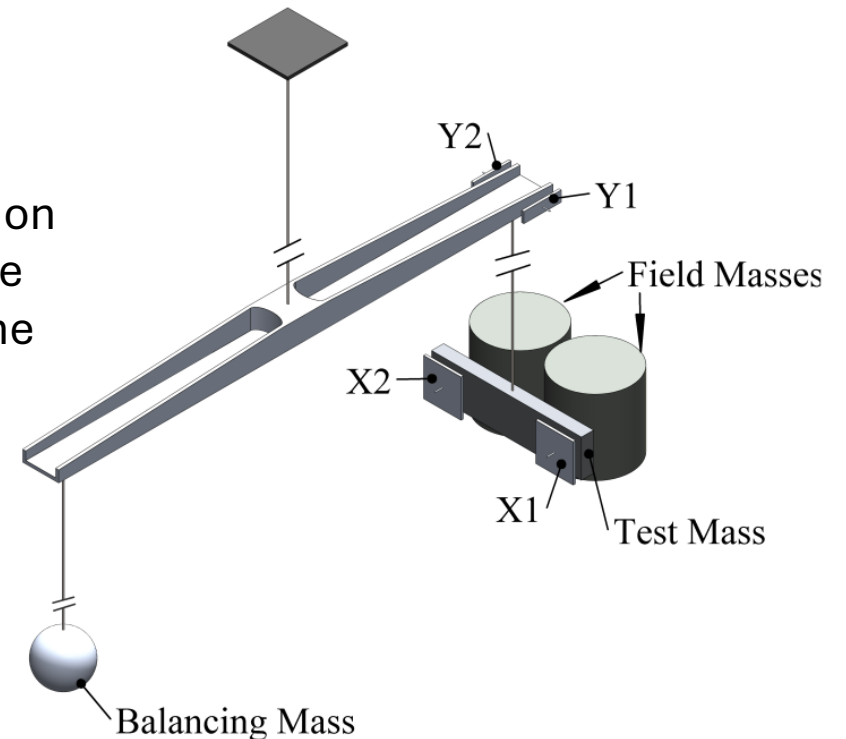

# Laser relative intensity noise measurement

## Context: LAG & LAG-M



The **Liquid Actuated Gravity (LAG)** experiment is a real and innovative R&D project by the Italian National Institute for Nuclear Physics (INFN), primarily investigating precise gravitational measurements using a novel liquid-based field mass.















Review of Scientific Instruments
ARTICLE

[pubs.aip.org/aip/rsi](https://pubs.aip.org/aip/rsi)

## Measurement of gravitational and thermal effects in a liquid-actuated torsion pendulum

Cite as: Rev. Sci. Instrum. 94, 114501 (2023); doi: [10.1063/5.0162604](https://doi.org/10.1063/5.0162604)  
 Submitted: 15 June 2023 • Accepted: 5 October 2023 •  
 Published Online: 1 November 2023

 View Online
 Export Citation
 CrossMark

Annalisa Allocca,<sup>1,2</sup>  Massimo Bassan,<sup>3,4,a)</sup>  Martina De Laurentis,<sup>2,5</sup>  Rosario De Rosa,<sup>1,2</sup>   
 Luciano Di Fiore,<sup>2</sup>  Luca D'Onofrio,<sup>1,2</sup> Luciano Errico,<sup>1,2</sup> Fabio Garufi,<sup>1,2</sup>  Aniello Grado,<sup>2,6</sup>  C. D. Hoyle,<sup>7</sup>   
 David Lucchesi,<sup>4,8</sup>  Yury Minenkov,<sup>4</sup> Giuseppe Passeggio,<sup>2</sup> Giuseppe Pucacco,<sup>3,4</sup>  Valeria Sequino,<sup>1,2</sup>   
 Oreste Tarallo,<sup>2,9</sup>  Lucia Trozzo,<sup>2</sup>  and Massimo Visco<sup>4,8</sup> 

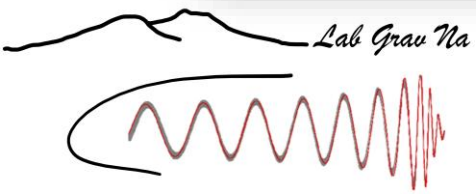
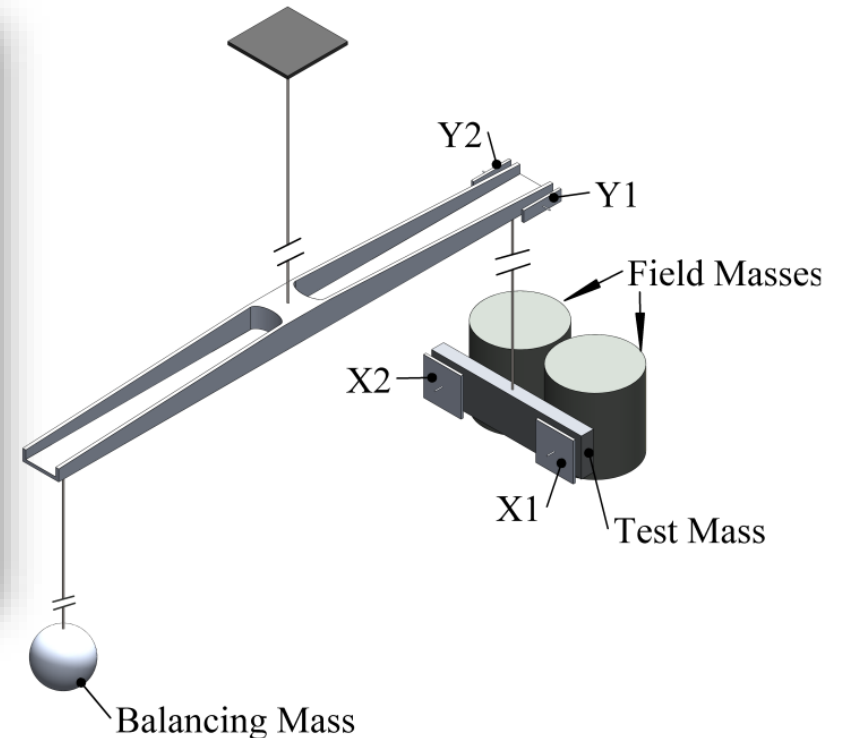

Rev. Sci. Instrum. 94, 114501 (2023)  
<https://doi.org/10.1063/5.0162604>

# Laser relative intensity noise measurement

## Context: LAG & LAG-M

Sketch of the LAG experiment  
(for ISL test)

$$V(\vec{r}) = -G \frac{M}{r} (1 + \alpha e^{-r/\lambda})$$

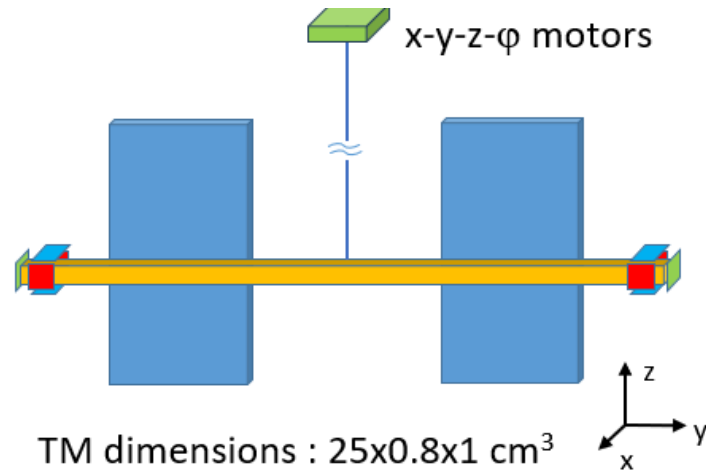

$$V(r) = -\frac{Gm_1m_2}{r} \left( 1 + \tilde{\alpha} \left[ \frac{\tilde{q}}{\tilde{g}\mu} \right]_1 \left[ \frac{\tilde{q}}{\tilde{g}\mu} \right]_2 e^{-r/\lambda} \right)$$

Sketch of LAG for WEP test

Material	Z	N
<a href="#">Tantalum</a>	73	107
<a href="#">Aluminum</a>	13	14
Mercury	80	116

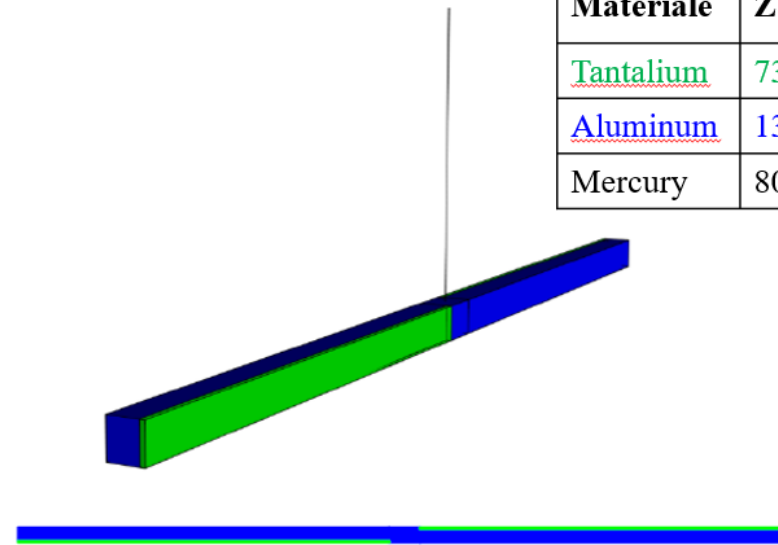

The TM has the same shape and size as the one for ISL, so that we can go from one measurement to the other by simply replacing the TM

(From L. Di Fiore – LAG meeting)

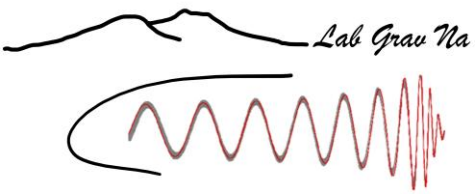

# Laser relative intensity noise measurement

## Context: LAG & LAG-M

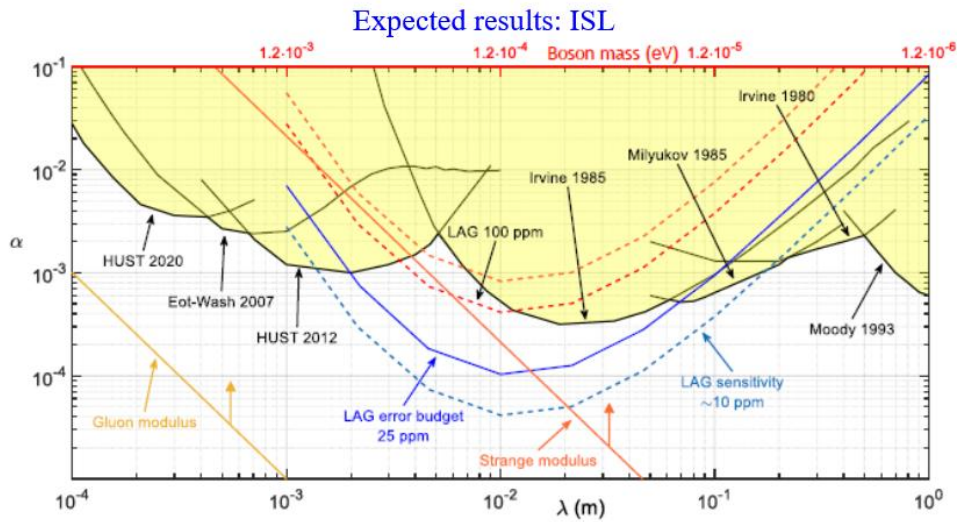

Figure 7 -  $\alpha$ - $\lambda$  exclusion plot in the .0001 to 1 m range. We also show the area potentially excluded by LAG (blue solid line) assuming 25 ppm accuracy and the limitation due to metrology accuracy at 200, 100 and 10 ppm (dashed lines form up to down)

- We can potentially improve upper limits in the range from 2 mm to 300 mm
- A detailed error budget indicates that we can reach  $\sim 25$  ppm)
- We can improve limit on strange modulus mass from  $\sim 3 \cdot 10^{-4}$  eV down to  $10^{-4}$  eV
- Limits on dilaton-like particles will be discussed together with WEP results

## Expected new limits from LAG on WEP

We can:

- considerably improve current upper limits on WEP violation below 3 cm range
- Test for the first time the still unexplored range below 1 mm, where extra dimension effects could manifest

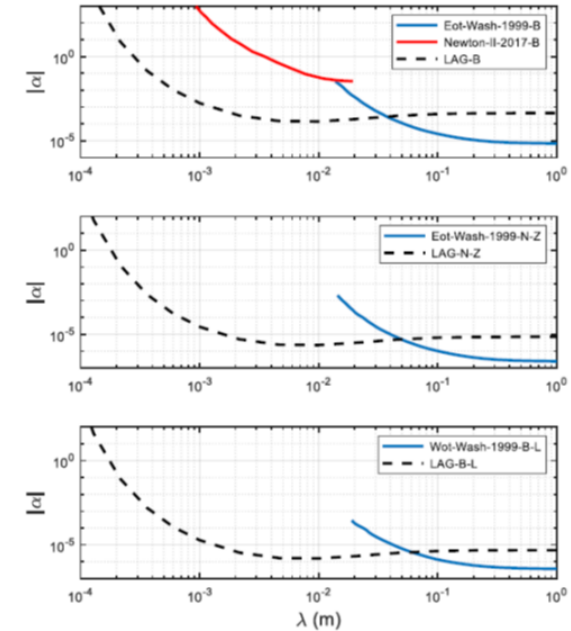
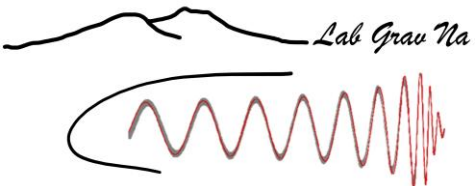

Figure 9 -  $\alpha$ - $\lambda$  plots for the hypothetical WEP violating charges  $B=N+Z$  (upper plot),  $N-Z$  (middle plot) and  $B-L$  (lower plot)



(From L. Di Fiore – LAG meeting)

Need to measure TM-FM distance with  $\sim 10$ ppm accuracy

# Laser relative intensity noise measurement

Context: LAG & LAG-M

**Possible source of violation on ISL and WEP that can be tested with LAG**

**Moduli:** very light (mass below  $10^{-3}$  eV) supersymmetric particles suggested by string theory, like gluon modulus, strange modulus and heavy quark moduli → ISL

see: S. [Dimopoulos](#) and G.F. Giudice, Physics Letters B 379 (1996) 105-114  
 S. [Dimopoulos](#) and A. Geraci, Phys. Rev. D 68, 124021 (2003)

**light scalars**, for example [dilaton](#)-like particles, that violate WEP, indicate extra dimensions and are light dark matter candidates. → ISL & WEP

see: T. [Damour](#) and J.F. Donoghue, Phys. Rev. D 82 084033 (2010)  
 T. [Damour](#) and J.F. Donoghue, Class. Quant. Grav. 27 202001 (2010)  
 C.G. Qin, et al., Phys. of the Dark Univ. 44, 101481 (2024)

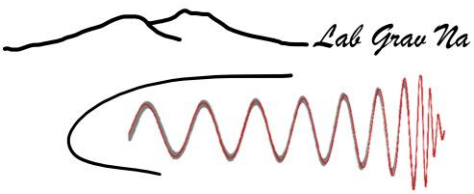

(From L. Di Fiore – LAG meeting)

# Laser relative intensity noise measurement

## Context: LAG & LAG-M

Need to measure TM-FM distance with  $\sim 10\text{ppm}$  accuracy

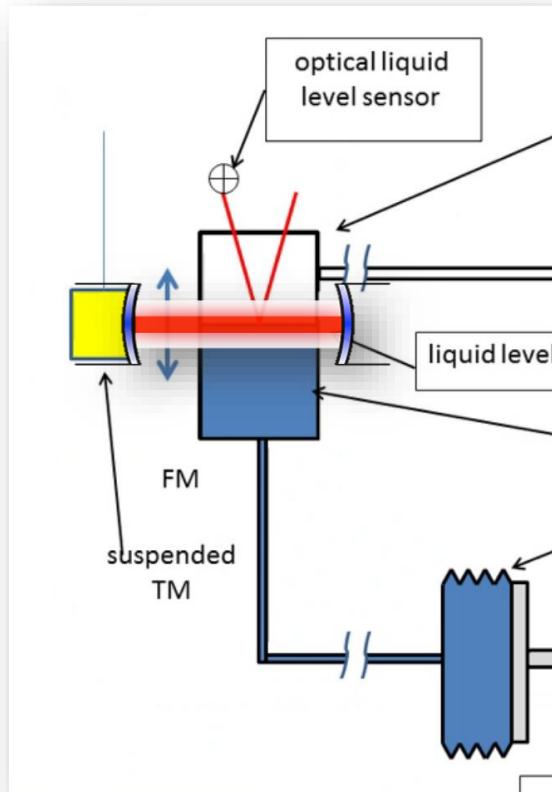

- ❑ A double modulation/demodulation of laser can be used to precisely determine the absolute length of an optical resonator
- ❑ Developed in GW community to tune the RF modulation to ensure a maximal transmission of sidebands through a mode-cleaner cavity, then applied to long baseline cavity length measurement in TAMA [1], LIGO [2], Virgo [3]
- ❑ Field mass and test mass of the LAG/MAG experiment could host the two mirrors of a Fabry-Perot
- ❑ Propose to use in lab gravity experiment for the first time to my knowledge

- [1] A. Araya et al. APPLIED OPTICS Vol. 38, No. 13 1 May 1999  
 [2] A. Staley et al. Opt. Express 23, 19417-19431 (2015)  
 [3] "fModErr" - unpublished

Lab Grav Na



# Laser relative intensity noise measurement

## Context: LAG & LAG-M

How it works (Fabry-Perot basics):

Need to measure TM-FM distance with ~10ppm accuracy

Resonance condition: phase changes by (a multiple of)  $2\pi$  per round-trip,

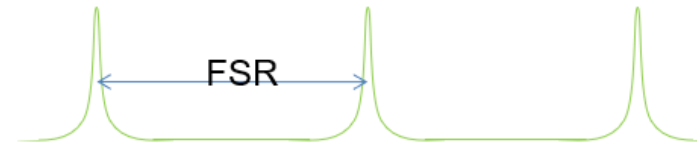
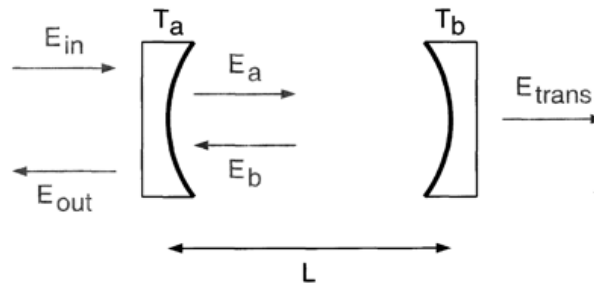

Finesse of the resonator is the ratio between FSR and cavity width

Free Spectral Range: distance between two consecutive resonances of the optical resonator

**Completely determined by cavity length**

**FSR =  $c / 2L$**

➤ Measurement of FSR directly translates in measuring the cavity length

The transmitted light power

$$\frac{P_{trans}}{P_{in}} = \frac{T_a T_b}{(1 - r_a r_b)^2 + 4 r_a r_b \sin^2(\phi/2)}$$

Light in the cavity experiences a round trip phase of  $\phi$ . On RESONANCE

$$\phi = 2n\pi \text{ or equivalently } f = \frac{c}{2L}n$$

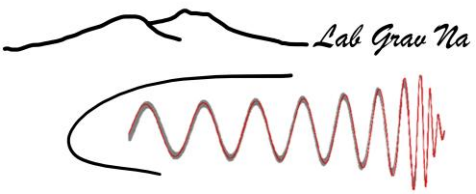

# Laser relative intensity noise measurement

## Context: LAG & LAG-M

(Main) sources of uncertainty:

- ❑ Error in the measurement of the probe RF frequency  $f_{\text{Mod}}$  directly translates into length error
- ❑ GPS timing synch provides accuracy up to 10ppb

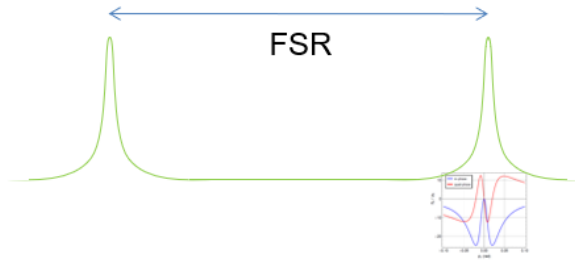

- ❑ Sensing error is a combination of **shot noise** on the sensor and Finesse of the cavity
- ❑ The larger the finesse, the steeper the slope of the error signal
- ❑ We will probably be limited to  $F < 100$  by golden mirror reflectivity

Need to measure TM-FM distance with  $\sim 10$ ppm accuracy

Need to know if there is any excess of RIN on the laser employed for the measurement

- ❑ In ref. [1] A. Araya et al. APPLIED OPTICS Vol. 38, No. 13 1 May 1999 they claim an accuracy of up to  $1e-10$
- ❑ In ref. [2] A. Staley et al. Opt. Express 23, 19417-19431 (2015) they obtained an accuracy of  $\sim 2e-7$
- ❑ In Virgo, unpublished result of an accuracy of  $\sim 2e-7$  for the IMC was obtained

IMC Cavity

Parameter	Value
FSR	1045129 Hz +/- 0.5 Hz
FWHM	1040 Hz +/- 8 Hz
F	1005 +/- 4
Half round trip	143.424 m +/- 30 $\mu$ m
Matching	93%
Round-trip losses	230 ppm
Throughput	92.9%

A.Chiummo – Opt Cav length – LAG/MAG 11/12/24

Lab Grav Na

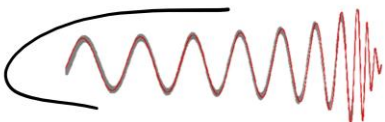

# Laser relative intensity noise measurement

- **Relative Intensity Noise (RIN):**

Fractional fluctuation of laser power:  $\delta P/P$ .

Important in precision optics, communication systems, and laser stabilization.

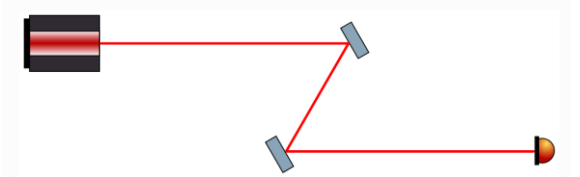

- **Traditional measurement:**

Shine the laser on a **single photodetector**, record the current fluctuations, and interpret them as RIN.

- **Detector noise is inseparable from laser noise**

- The detector adds its own thermal noise, electronic noise, and **1/f flicker noise**.
- Because you *cannot turn the laser off*, there's no way to measure the detector noise alone under real operating conditions.

- **Excess and parasitic noises don't follow simple models**

- Low-frequency noises (flicker, environmental drifts) do not obey clean theoretical laws, making it hard to subtract or predict them.

- **Validation becomes impossible**

- Since detector noise cannot be measured independently and reference sources are unavailable, you cannot check whether the measured spectrum truly represents the laser or is contaminated by the instrument.

- **Consequence:**

The single-channel method can give **misleading RIN measurements** where detector noise is mistaken for laser noise—especially at low frequency where flicker dominates.

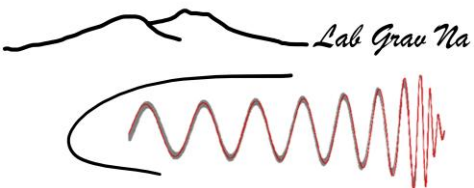

# Laser relative intensity noise measurement

- Idea: Use **two independent detectors** measuring the same laser beam
- Each detector sees:
  - Signal (the laser's fluctuations) + its own noise
- Formulas (Eqs. 3–4):
  - $x(t) = c(t) + a(t)$
  - $y(t) = c(t) + b(t)$
- Compute the **cross-spectrum** (Eq. 2):
  - $S_{yx}(f) = \langle Y(f)X^*(f) \rangle_m$  averaged over a suitable number  $m$  of spectra samples
- Because detector noises  $a$  and  $b$  are uncorrelated, they average out as  $1/\sqrt{m}$
- What remains is the **true laser noise** (Eq. 5)
- See **Figure 1** in the paper

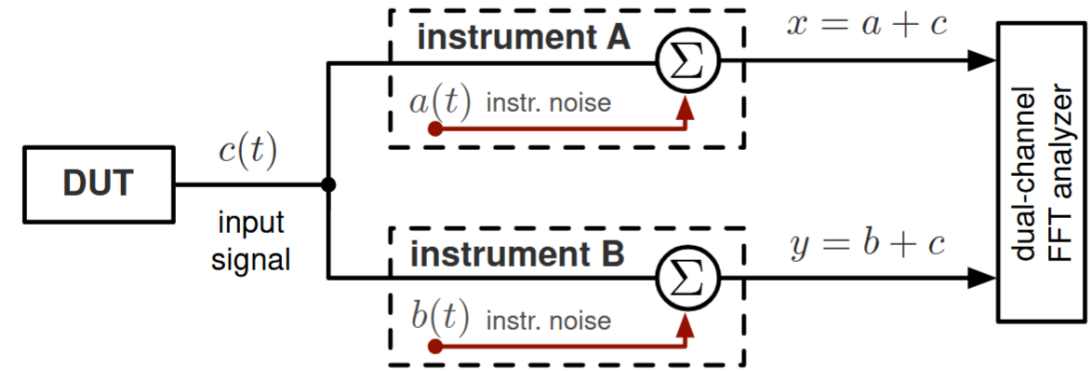

Fig. 1. Basic cross-spectrum measurement.

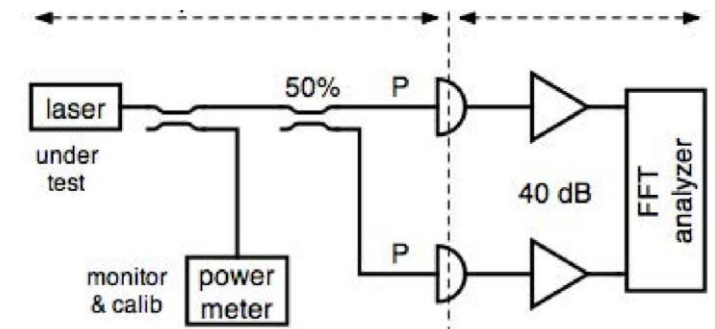
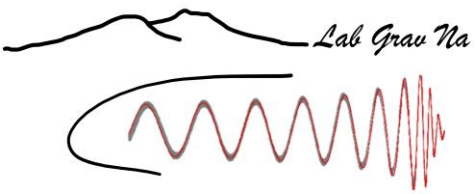

Fig. 3. Basic RIN measurement method.

$$\begin{aligned}
 S_{yx}(f) &= \langle CC^* \rangle_m + \langle CB^* \rangle_m + \langle AC^* \rangle_m + \langle AB^* \rangle_m \\
 &= S_c(f) + O(\sqrt{1/m}),
 \end{aligned}
 \tag{5}$$



# Laser relative intensity noise measurement

- All hardware available in PLaNET
- You will learn:
  - Basic laser operation
  - Fiber optics manipulation
  - Photodiode linearity measurement
  - Balanced detection
  - Cross-spectrum measurement
  - Use of advanced Spectrum Analyzer

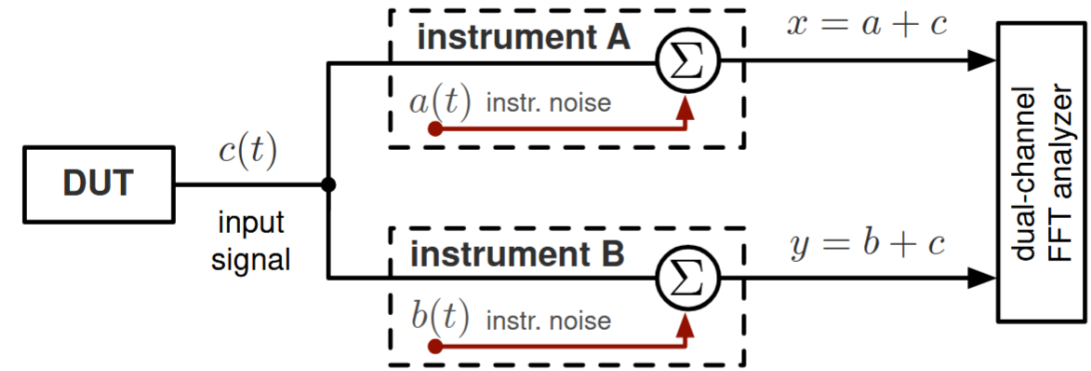

Fig. 1. Basic cross-spectrum measurement.

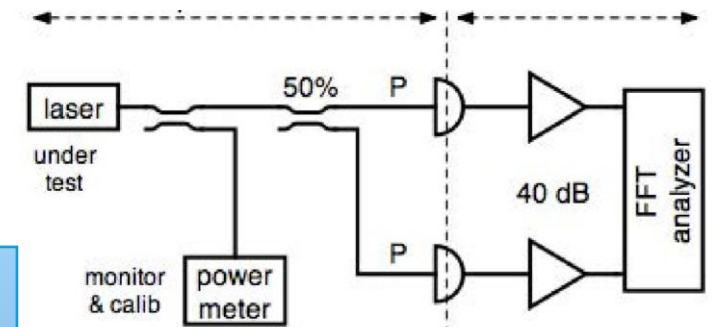

Fig. 3. Basic RIN measurement method.

- Time scale of 3/4 afternoons for experimental work
- Probably one (?) more week of data analysis and report
- Can start likely on the second week of December

Contact: [Antonino.Chiummo@na.infn.it](mailto:Antonino.Chiummo@na.infn.it) - room 1G22a

