

# Designing and Testing cdma2000 Base Stations

Application Note 1357

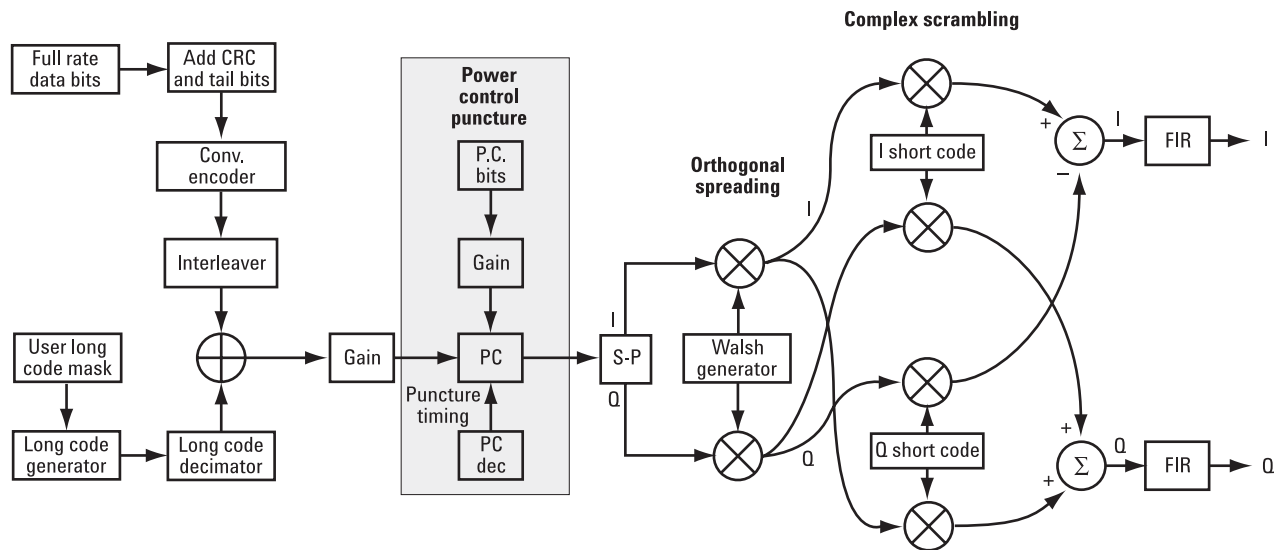

# Table of contents

<b>Introduction</b> .....	<b>.3</b>
<b>1 Basic concepts of cdma2000</b> .....	<b>.4</b>
1.1 Spreading rate .....	.4
1.2 Radio configuration .....	.5
1.3 Forward link air interface .....	.5
1.4 Reverse link air interface – HPSK .....	.6
1.5 Forward link power control .....	.8
1.6 Differences between cdma2000 and W-CDMA .....	.8
<b>2 Design and measurement issues</b> .....	<b>.9</b>
2.1 Handling high peak-to-average power ratios .....	.9
2.1.1 CCDF .....	.10
2.1.2 ACPR .....	.13
2.2 Measuring modulation accuracy .....	.14
2.2.1 QPSK EVM .....	.14
2.2.2 Composite rho .....	.17
2.2.3 Code domain power .....	.20
2.2.4 Symbol EVM .....	.26
2.2.5 Symbol power versus time .....	.28
2.2.6 Demodulated bits .....	.29
<b>Appendix A: cdma2000 Walsh code table</b> .....	<b>.30</b>
<b>Appendix B:</b>	
<b>Agilent solutions for cdma2000 BTS design and test</b> .....	<b>.35</b>
<b>Acronym glossary</b> .....	<b>.39</b>
<b>References</b> .....	<b>.40</b>
<b>Related literature</b> .....	<b>.40</b>

# Introduction

One of the technologies meeting the IMT-2000 requirements for a third generation (3G) global wireless communications system is cdma2000, also known as IS-2000<sup>1</sup>. The Third-Generation Partnership Project 2 (3GPP2) is implementing this wideband code division multiple access (CDMA) system as a derivative of the IS-95-B CDMA system, also known as cdmaOne. The 3GPP2 organizational partners are Association of Radio Industries and Businesses (ARIB), Telecommunication Technology Committee (TTC), Telecommunications Technology Committee (TIA), and Telecommunications Technology Association (TTA).

As the IS-2000 standards are finalized, the first base stations are being integrated and tested. This application note describes base transceiver station (BTS) design and measurement issues at the physical layer (layer 1) that may differ between cdma2000 and cdmaOne. Although it focuses on the last stages of BTS development and integration, it is also useful for engineers working in the early stages of manufacturing. The application note also provides a list of Agilent Technologies cdma2000 solutions for these topics.

This application note assumes that you are familiar with cdmaOne measurements and technology basics. cdmaOne is used as a reference throughout this application note. The main differences between cdmaOne and cdma2000 systems and the corresponding design and measurement implications are highlighted. For more information on cdmaOne measurements see [1].

This application note can be downloaded from the Agilent Technologies web site and printed locally from this url: <http://www.agilent.com/find/3G> located under "Technical Papers".

---

1. IS-2000 is the Telecommunications Industries Association's (TIA's) standard for 3G technology that is an evolution of cdmaOne technology. cdma2000, which is often used interchangeably with IS-2000, is also used to refer to the access format and system.

# 1 Basic concepts of cdma2000

The main advantages that cdma2000 offers over other IMT-2000 proposals are backward compatibility with cdmaOne systems and a smooth migration from second-generation (2G) cdmaOne systems to 3G. Figure 1 shows the potential evolution path from cdmaOne to cdma2000 systems.

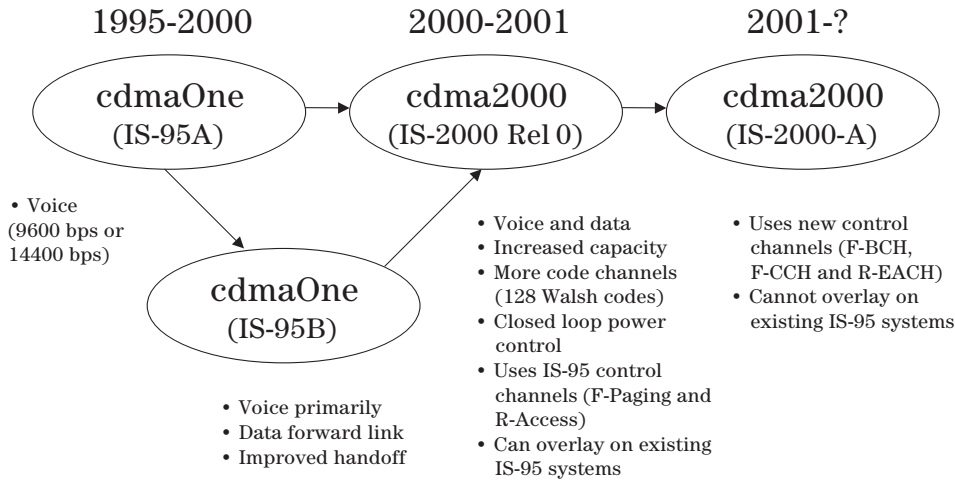

Figure 1. Evolution from cdmaOne to cdma2000

## 1.1 Spreading rate

Spreading rate (SR) defines the final spread chip rate in terms of 1.2288 Mcps. The two spreading rates are SR1 and SR3.

**SR1:** An SR1 cdma2000 signal has a chip rate of 1.2288 Mcps and occupies the same bandwidth as cdmaOne signals. The SR1 cdma2000 system doubles the system capacity and therefore can be considered an improved cdmaOne system. The main differences from cdmaOne are:

- fast power control and quadrature phase shift keying (QPSK) modulation rather than dual binary phase shift keying (BPSK) in the forward link
- pilot signal, to allow coherent demodulation, and hybrid phase shift keying (HPSK) spreading in the reverse link

**SR3:** An SR3 cdma2000 signal has a rate of 3.6864 Mcps (3 x 1.2288 Mcps) and occupies three times the bandwidth of cdmaOne. Originally, the SR3 system appeared to be viable. Upon further investigation the SR3 cdma2000 system was determined to not be viable and is no longer receiving any commercial attention at this time. Therefore, we will not be covering SR3 in this application note.

## 1.2 Radio configuration

Radio configuration (RC) defines the physical channel configuration based upon a specific channel data rate. Each RC specifies a set of data rates based on either 9.6 or 14.4 kbps. These are the two existing data rates supported for cdmaOne. Each RC also specifies the SR (either SR1 or SR3) and the physical coding. Currently there are nine RCs defined in the cdma2000 system for the forward link and six for the reverse link.

Examples are:

- RC1 is the backwards compatible mode of cdmaOne for 9600-bps voice traffic. It includes 9.6, 4.8, 2.4, and 1.2 kbps data rates and operates at SR1. It does not use any of the new cdma2000 coding improvements.
- RC3 is a cdma2000 specific configuration based on 9.6 kbps that also supports 4.8, 2.7, and 1.5 kbps for voice, while supporting data at 19.2, 38.4, 76.8, and 153.6 kbps and operates at SR1.

Each BTS or mobile station (MS) must be capable of transmitting using different RCs at the same SR. Refer to [2] for detailed information on the different RCs.

## 1.3 Forward link air interface

The forward link air interface for a cdma2000 SR1 channel is very similar to that of cdmaOne. In order to preserve compatibility, cdma2000 uses the same structure as cdmaOne for the forward pilot (F-Pilot), forward sync (F-Sync), and forward paging (F-Paging) channels.

In cdma2000, each user is assigned a forward traffic (F-Traffic) channel, which consists of

- zero to one forward fundamental channel (F-FCH)
- zero to seven forward supplemental code channels (F-SCCHs) for RC1 and RC2
- zero to two forward supplemental channels (F-SCHs) for RC3 to RC9
- zero to one forward dedicated control channels (F-DCCHs)

The F-FCHs are used for voice and the F-FCCHs and F-SCHs are used for data. The BTS may also send zero to one F-DCCH. An F-DCCH is associated with traffic channels (either FCH, or SCH, or SCCH) and may carry signaling data and power control data.

One of the main differences between cdmaOne and cdma2000 is that the latter uses true quadrature phase shift keying (QPSK) modulation (as opposed to dual-BPSK) for all traffic channels from RC3 to RC9. As an example, figure 2 shows the forward link structure for an RC4 F-FCH. The coding is identical to cdmaOne up through the long code scrambling of the voice data. The F-FCH is optionally punctured with the reverse link power control data bits. The data is then converted from a serial bit stream into a 2-bit-wide parallel data stream to produce true quadrature phase shift keying (QPSK) modulation. This reduces the data rate of each stream by a factor of two. Each branch is spread with a 128 Walsh code to generate a SR of 1.2288 Mcps. In this case, the processing gain is doubled for each channel relative to cdmaOne. Each channel is transmitted at one-half the power used before, but there are now two of them with no apparent gain. The actual processing gain for each channel depends on its data rate and RC.

The outputs of the I and Q Walsh spreaders are then complex multiplied against the same I and Q channel short codes used in cdmaOne. Complex scrambling is used in the forward link instead of regular scrambling because it is a more robust scheme against interference.

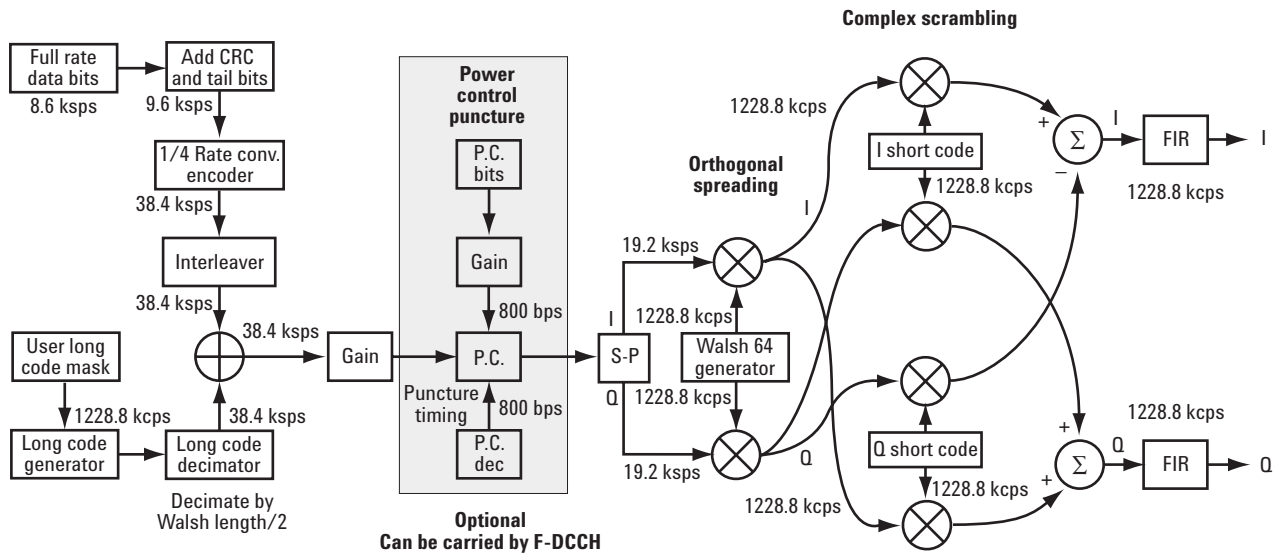

Figure 2. Coding and air interface for a cdma2000 RC4 F-FCH

## 1.4 Reverse link air interface—HPSK

The cdma2000 reverse link is very different from that of cdmaOne. The MS can transmit more than one code channel to accommodate the high data rates. The minimum configuration consists of a reverse pilot (R-Pilot) channel to allow the BTS to perform synchronous detection and a reverse fundamental channel (R-FCH) for voice. Additional channels, such as the reverse supplemental channels (R-SCHs) and the reverse dedicated control channel (R-DCCH) can be used to send data or signaling information, respectively.

The different channels are assigned to either the I or Q path. For example, for RC3 to RC6, the R-Pilot is assigned to I and R-FCH is assigned to Q (see figure 3).

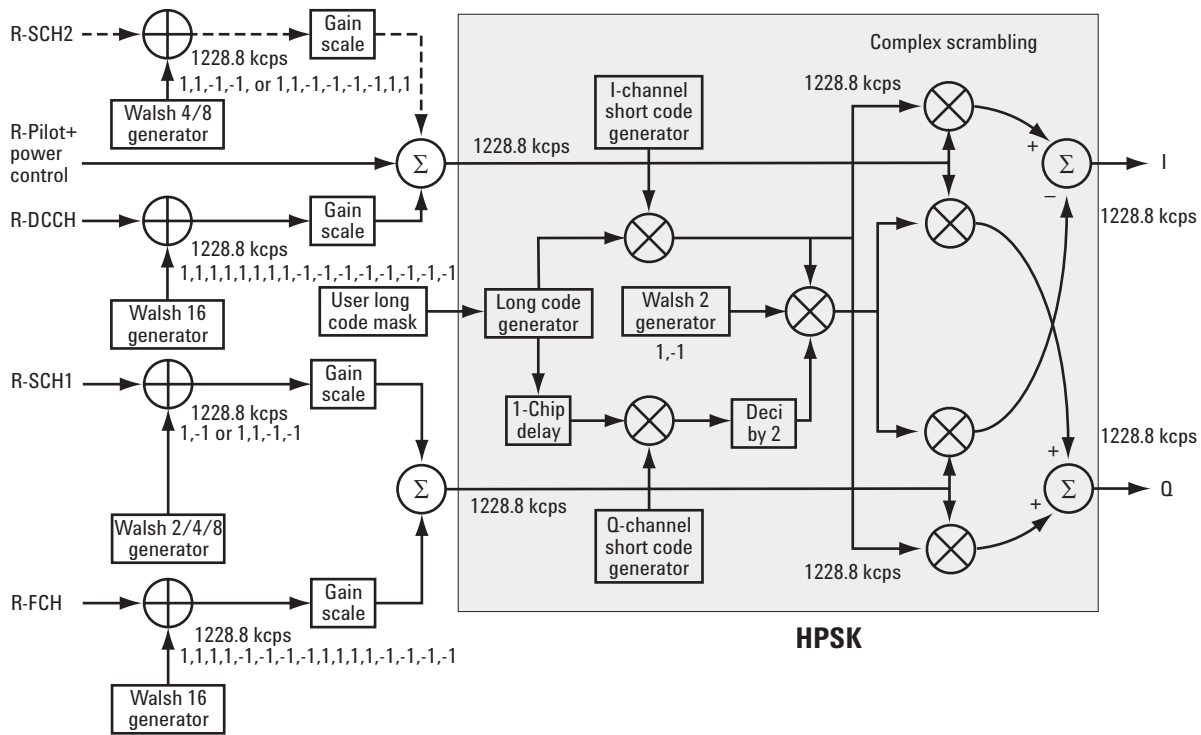
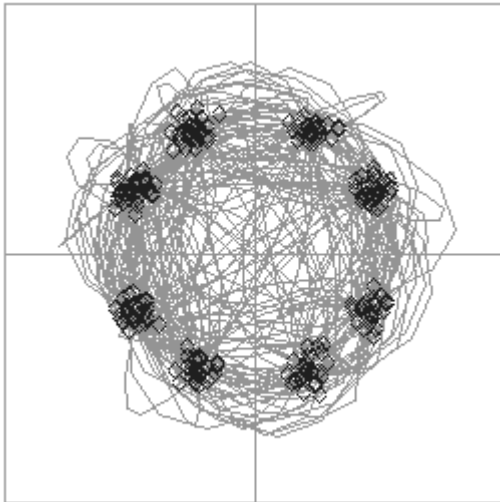

Figure 3. An example of channel summing and HPSK spreading in cdma2000 reverse link (SR1).

Channels can be at different rates and different power levels. Complex scrambling facilitates this by continuously phase rotating the constellation and thus distributing the power evenly between the axes.

Without scrambling, unequal channel powers would result in a rectangular four-quadrature amplitude modulation (QAM) constellation (assuming that only R-Pilot and R-FCH are active). With complex scrambling, the constellation for two channels generally has eight points distributed around a circle, with the angular distribution determined by the relative powers of the two channels. For example, an amplitude difference of 6 dB between the two channels results in the constellation shown in figure 4, which is close to an 8-PSK (8-phase shift keying) constellation (an amplitude difference of 7.65 dB would result in a perfect 8-PSK constellation). If the amplitudes for the two channels are equal, then pairs of constellation points merge to give a QPSK-like constellation.

I/Q measured polar vector



**Figure 4. A reverse link cdma2000 SR1 signal with an R-Pilot and an R-FCH. The amplitude of the R-FCH is 6 dB lower than that of the R-Pilot.**

Basic complex scrambling applies a phase rotation of  $0$ ,  $\pm\pi/2$ , or  $\pi$  radians to each chip. HPSK takes this idea a stage further and defines the complex scrambling so that for every second chip, the phase rotation is restricted to  $\pm\pi/2$ . This constraint on the phase transitions entering the baseband pulse shaping filter reduces the peak-to-average ratio of the signal (about 1 to 1.5 dB) compared to regular complex scrambling (or regular QPSK). The HPSK technique continues to be advantageous even when the signal has more than two channels. For more information on HPSK see [3].

## 1.5 Forward link power control

A key improvement in cdma2000 is forward link power control. The MS sends power control data back to the BTS by time multiplexing it with the R-Pilot channel. Like the existing reverse link closed loop power control of cdmaOne, the cdma2000 forward link closed loop power control sends 800 power control bits each second. These bits indicate whether the BTS should raise or lower its power in 1 dB, 0.5 dB, or 0.25 dB. The finer steps allow tighter power control for low mobility or stationary phones. Tighter control (less power ripple) lowers the average power and thus raises the capacity of the system.

## 1.6 Differences between cdma2000 and W-CDMA

The Third-Generation Partnership Project (3GPP) W-CDMA is the other main wideband CDMA technology competing for the 3G cellular market. There has been much discussion about the need to harmonize W-CDMA and cdma2000 in an attempt to facilitate global use of 3G phones. However, even though both systems are based on a similar CDMA technology, they are significantly different. The main differences are

- the SR (3.84 Mcps for W-CDMA versus 1.2288 Mcps for cdma2000 SR1)
- the synchronization and BTS identification methodology (W-CDMA does not use global positioning system (GPS))

For information on W-CDMA BTS design and test issues, please refer to [4].

## 2 Design and measurement issues

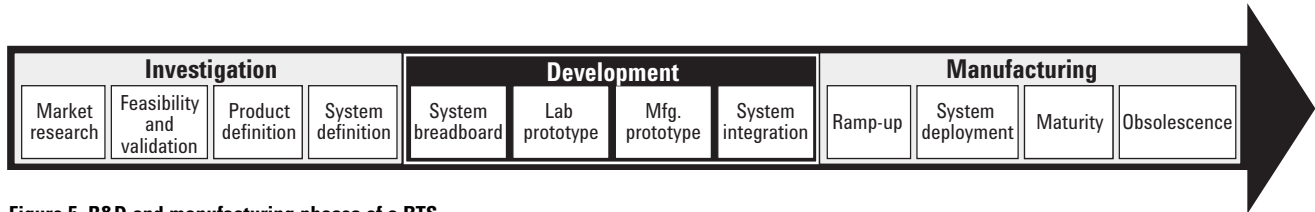

**Figure 5. R&D and manufacturing phases of a BTS**

Figure 5 is a generic diagram of the R&D and manufacturing phases of a BTS. This chapter focuses on the development phase of the BTS, highlighted in black. However, it contains general information that may be useful to engineers involved in any area of the BTS life cycle.

This chapter describes design and measurement issues that you may encounter when designing and testing a cdma2000 BTS, in contrast to cdmaOne. Although the exact cdma2000 measurement specifications are not finalized, in general we can assume that the basic measurement methodology will be similar to cdmaOne. Therefore, in this section cdmaOne measurements are used as a reference. For information on cdmaOne measurements see [1].

Refer to appendix B for a list of Agilent solutions available for BTS design and test.

### 2.1 Handling high peak-to-average power ratios

Peak-to-average power ratio is the ratio of the peak envelope power to the average envelope power of a signal. In cdma2000, as in cdmaOne, the power statistics of the signal depend on its channel configuration, modulation, filtering, clipping level, etc. In general, the peak-to-average power ratio increases as more channels are activated.

Component design, particularly power amplifier design, is challenging because the amplifier must be capable of handling the high peak-to-average power ratios that the signal exhibits, while maintaining a good adjacent channel power ratio (ACPR) performance. The use of MC power amplifiers pushes design complexity even one step further.

From the measurement perspective, the statistics of the signal may impact the result of the measurement, particularly in the case of ACPR. Therefore, it is important to choose the signal configuration carefully.

From both the design and measurement perspectives, you must cover the real-life worst cases, such as those with the most stressful signal configurations or highest peak-to-average power ratios. To accomplish this, you need a way to define the statistics of cdma2000 signals. The complementary cumulative distribution function (CCDF) takes care of that.

### 2.1.1 CCDF

The CCDF fully characterizes the power statistics of the signal [5]. It provides the distribution of particular peak-to-average power ratios versus probability.

Figure 6 shows the CCDF curves for two cdma2000 SR1 signals with different channel configurations. For a probability of 0.1 percent, the signal with 15 code channels has a higher peak-to-average ratio (7.96 dB) than the signal with 4 code channels (7.26 dB).

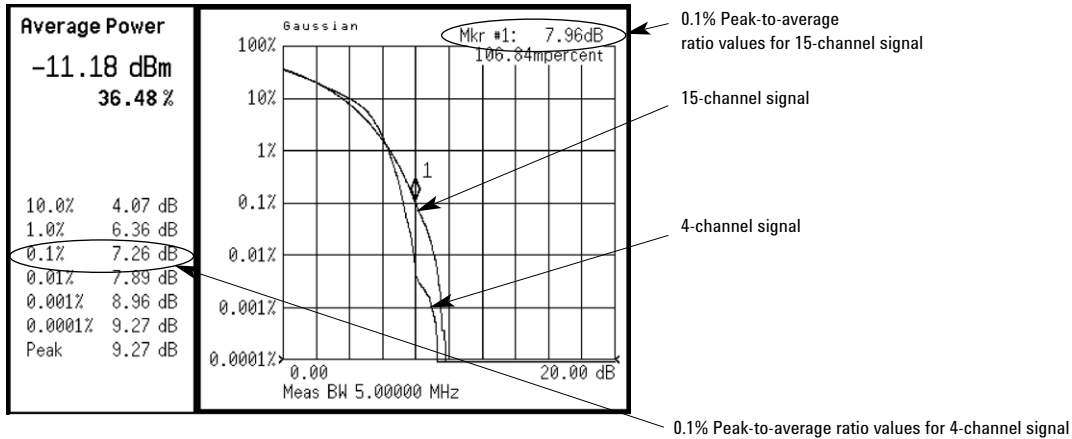
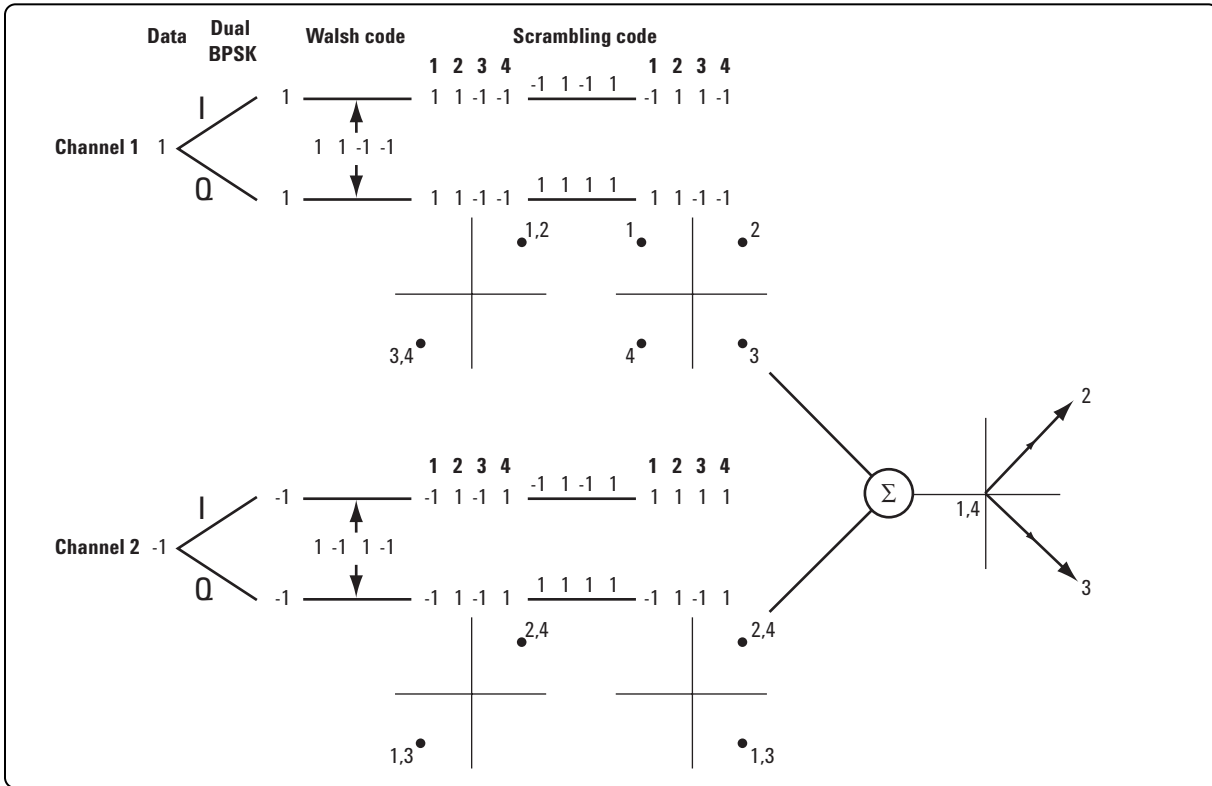

**Figure 6. CCDF curves for cdma2000 signals with different code channel configurations — marker at 0.1% probability**

So, how do the statistics of cdmaOne compare to the statistics of cdma2000? As mentioned earlier, it depends on the channel configuration. For a single traffic channel, the CCDF of the cdma2000 signal is almost the same as the CCDF of the cdmaOne signal. However, for multi-channel signals, the CCDFs are significantly different.

In general, a multi-channel cdma2000 signal is significantly less stressful than a multi-channel cdmaOne signal with a similar channel configuration. This is mostly because cdma2000 uses true QPSK modulation as opposed to dual BPSK. True QPSK modulation provides more possibilities for the I/Q locations of the chip points than dual BPSK prior to scrambling. Scrambling randomizes the chip locations for a single channel, but all channels use the same scrambling code; therefore, they are synchronously randomized. A higher number of I/Q location possibilities prior to the scrambling results in more random outputs between channels. Dual BPSK always maps the chip signal onto the same two I/Q locations prior to the scrambling (figure 7a), while true QPSK has four I/Q location possibilities (figure 7b). Therefore, QPSK provides less alignment between chip sequences from different channels, which results in a lower peak-to-average power ratio.

**(a) Dual BPSK**



**(b) QPSK**

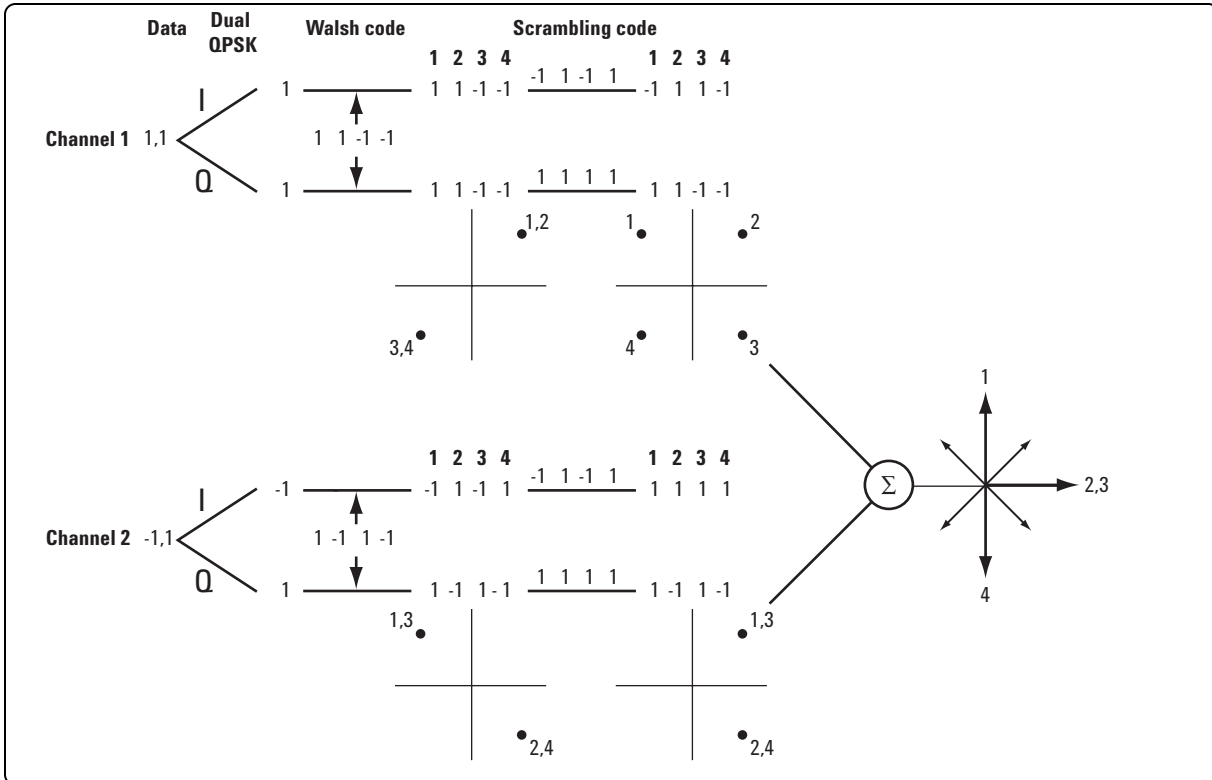
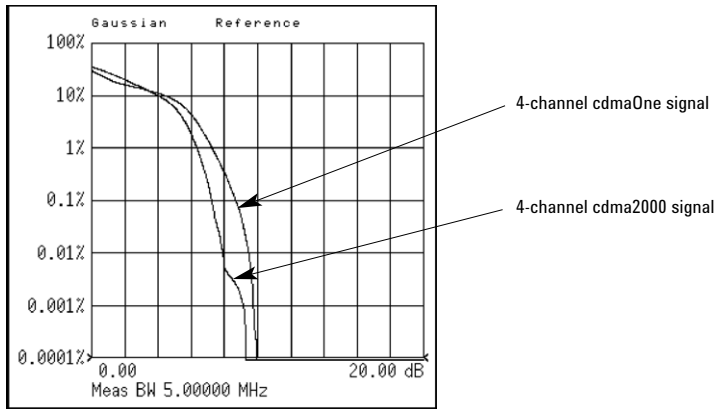
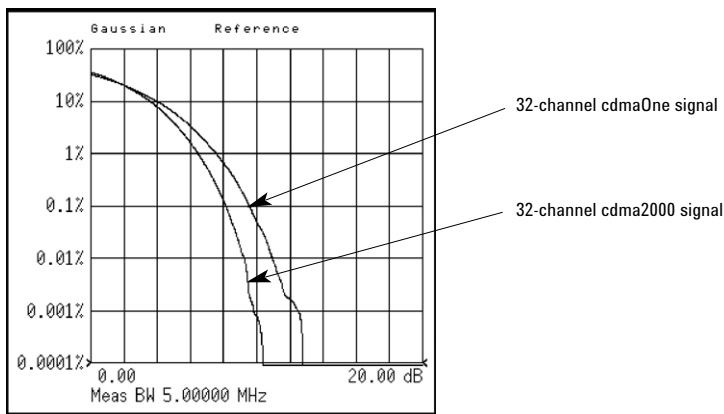

Figure 7. Result of combining (a) two dual BPSK channels versus (b) two QPSK channels

Figures 8 and 9 compare the CCDFs of cdmaOne signals to cdma2000 SR1 signals with similar configurations. In both cases, the cdma2000 signal is significantly less stressful.



**Figure 8. CCDF curves for a cdmaOne signal with four channels (pilot, sync, paging and one traffic channel) and for a cdma2000 signal with four channels (pilot, sync, paging, and one RC3 traffic channel). All channels are at the same amplitude.**



**Figure 9. CCDF curves for a cdmaOne signal with 32 channels (pilot, sync, paging, and 29 traffic channels) and for a cdma2000 signal with 32 channels (pilot, sync, paging, and 29 RC3 traffic channels). All channels are at the same amplitude.**

CCDF curves can help you in several situations:

- Determining the headroom required when designing a component. Correlate the CCDF curve of the signal with the amplifier gain plots [5]
- Confirming the power statistics of a given signal or stimulus. CCDF curves allow you to verify if the stimulus signal provided by another design team is adequate. Example: RF designers can use CCDF curves to verify that the signal provided by the digital signal processing (DSP) section is realistic.
- Confirming that the component design is adequate or troubleshooting your subsystem or system design. CCDF measurements can be made at several points of the system design. Example: if the ACPR of the transmitter is too high, CCDF measurements can be made at the input and output of the power amplifier. If the amplifier design is correct, the curves coincide and if the amplifier compresses the signal, the peak-to-average power ratio of the signal is lower at the output of the amplifier.

### 2.1.2 ACPR

The ACPR is usually defined as the ratio of the average power in the adjacent frequency channel (or at a specified frequency offset) to the average power in the transmitted frequency channel. The ACPR measurement is not part of the IS-95 standard, however, individual network equipment manufacturers typically specify ACPR as a figure of merit for component testing [1].

As mentioned earlier, when testing ACPR, it is important to take into account the power statistics of the signal. A signal with a higher peak-to-average ratio may cause more interference in the adjacent channel. Thus, ACPR measurements can provide different results depending on the signal configuration. The safest approach is to select at least one high stress cdma2000 stimulus signal and test with various combinations of channels.

Figure 10 shows an example of an ACPR measurement for a cdma2000 SR1 signal.

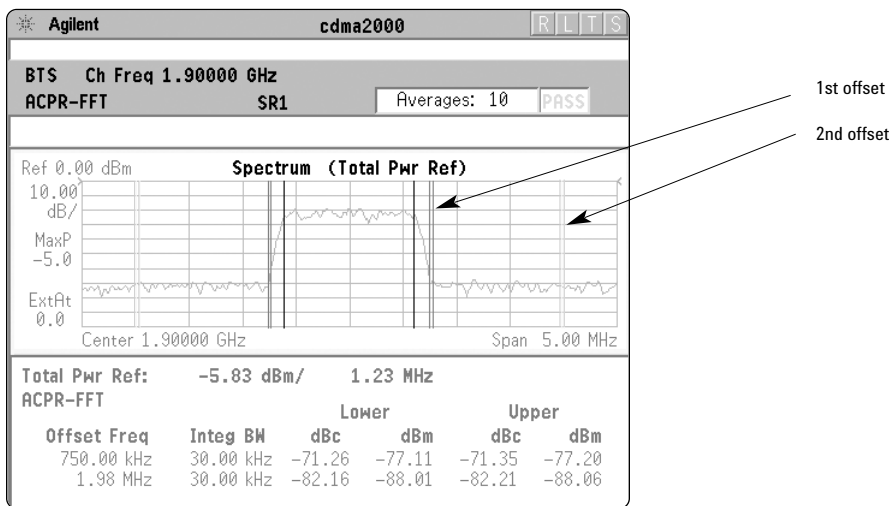

Figure 10. ACPR measurement for a cdma2000 SR1 signal

## 2.2 Measuring modulation accuracy

There are many measurements available to analyze the modulation accuracy of a cdma2000 BTS transmitter, such as, rho, QPSK error vector magnitude (EVM), composite EVM, code domain power, symbol EVM per code channel, etc. Apart from their basic algorithms, these measurements differ mainly in three aspects:

- whether you can use them to analyze a signal with a single (QPSK EVM) or multiple (composite rho, code domain power, symbol EVM) code channels
- if you can use them to analyze multi-channel signals, whether they provide information about each channel (code domain power, symbol EVM) or about the overall signal with no differentiation between channels (composite rho)
- how (to what degree of demodulation) and at what level (chip, symbol) the reference is computed

The best measurement to use depends on the design stage and the test purpose. In general, these measurements can complement each other by providing additional pieces of information. The following sections intend to clarify what information these measurements provide and when to apply them.

### 2.2.1 QPSK EVM

In digital communication systems, signal impairment can be objectively assessed by looking at the constellation and taking the displacement of each measured dot from the reference position as an error phasor (or vector), as shown in figure 11.

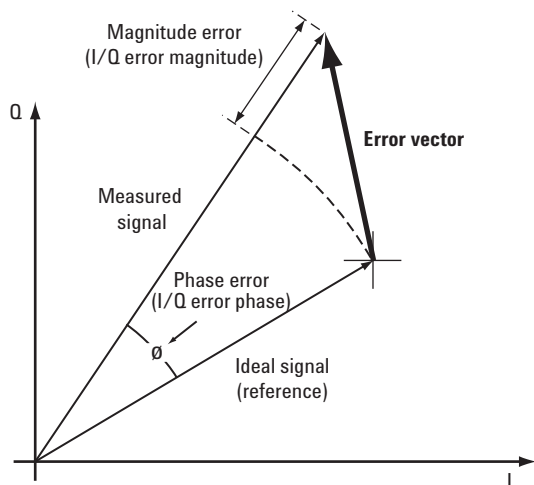
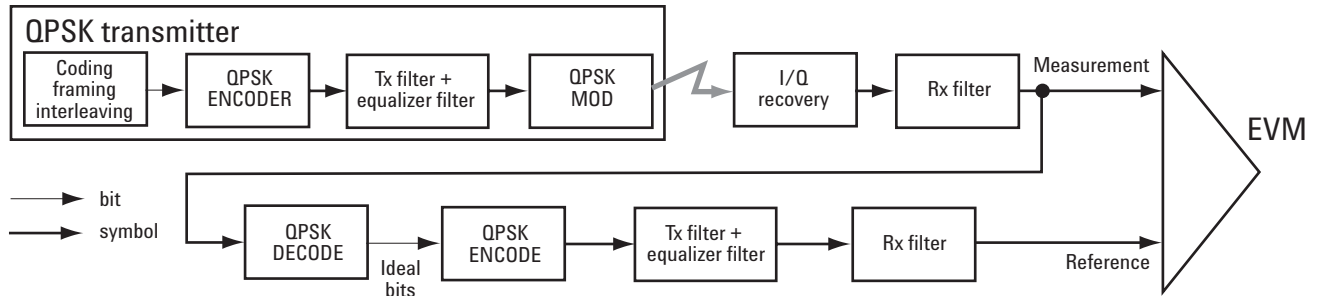

Figure 11. Error vector and related parameters

The reference position is determined from a reference signal that is synthesized by demodulating the received signal to symbols and then remodulating these symbols "perfectly". For example, figure 12 shows how the ideal reference is calculated for a QPSK signal.



**Figure 12. Process to calculate EVM for a QPSK signal**

The root mean square (RMS) of the error vectors is computed and expressed as a percentage of the overall signal magnitude. This is the EVM. EVM is a common modulation quality metric widely used in digital communication systems. (See [6] for more information on using EVM as a troubleshooting tool.)

For a QAM or a phase shift keying (PSK) signal, the ideal symbol points always map onto a few specific locations in the I/Q plane. cdma2000 uses a QPSK format to modulate the spread signal (chips). However, the signal consists of several code channels. The final constellation at the RF does not typically look like QPSK or any other known constellation, except for some specific channel configurations. For example, a signal with a single code channel does map onto a QPSK constellation.

You can use a regular QPSK EVM (uncoded EVM) measurement to evaluate the modulation quality of the transmitter for a single-code signal. This measurement compares the measured chip signal at the RF with an ideal QPSK reference. The signal analyzer may use either of the following methodologies to make a QPSK EVM measurement:

1. **Measure QPSK EVM on the received signal:** filtering the recovered I/Q signal with a complementary receiver filter and comparing it with a reference signal calculated by filtering the demodulated signal with the transmitter, equalizer, and receiver filters (figure 13a).
2. **Measure QPSK EVM on the transmitted signal:** comparing the I/Q recovered signal directly with a reference signal calculated by filtering the ideal chips with the transmitter and equalizer filters (figure 13b).

Both methods yield similar EVM results and you can use either of them to make valid modulation quality measurements of the BTS transmitter, however, the resulting constellation looks different. The first method results in four discrete constellation points. The second method results in a fuzzy constellation, as shown in figure 14a. Both constellations are correct. The reason for the difference is that the first constellation shows what the receiver sees after filtering, while the second one displays the constellation of the transmitted signal before applying receiver filtering.

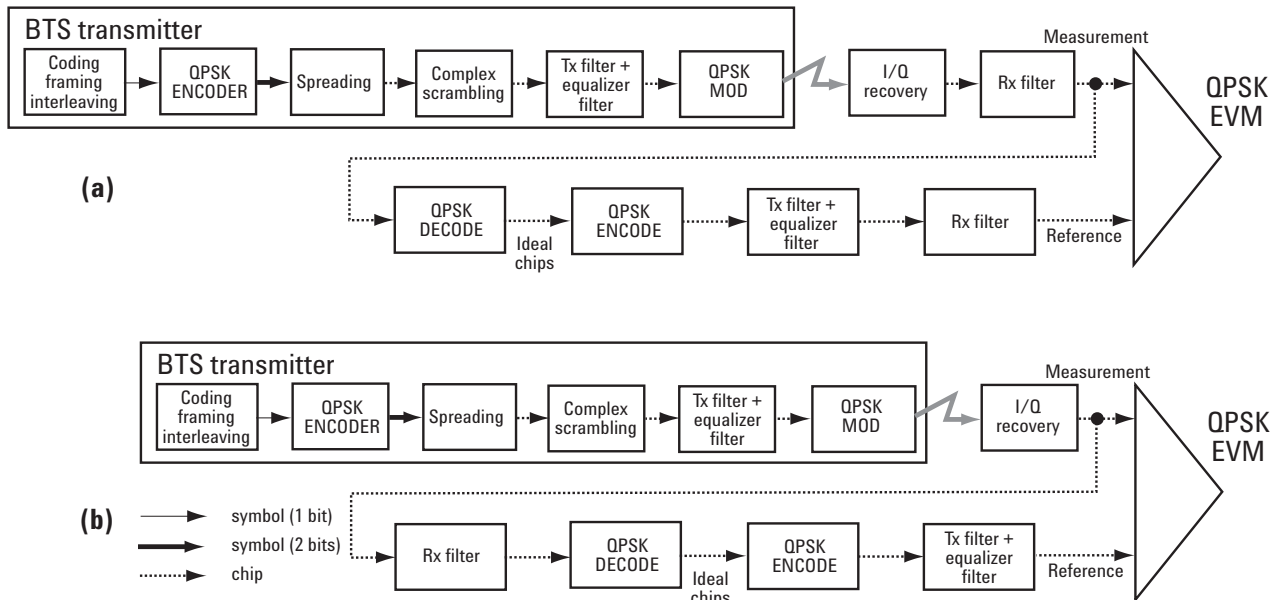

**Figure 13. Process to calculate QPSK EVM for a cdma2000 reverse link signal**

In any case, QPSK EVM does not descramble and despread the signal into symbols and back into chips to calculate the appropriate reference. Therefore, it can detect baseband filtering, modulation, and intermediate frequency (IF) and radio frequency (RF) impairments, but does not detect spreading or scrambling errors. In addition, QPSK EVM cannot evaluate the modulation quality of a multi-channel signal.

If it is impossible to despread or descramble the signal, the QPSK EVM measurement may be the only choice. In this sense, the QPSK EVM measurement can be useful to RF designers or system integrators to evaluate the modulation and quality of the analog section of the transmitter when the spreading or scrambling algorithms are not available or do not work properly. For example, figure 14 shows a QPSK EVM measurement for a single RC3 traffic channel for a transmitter with and without a local oscillator (LO) instability (phase noise) problem.

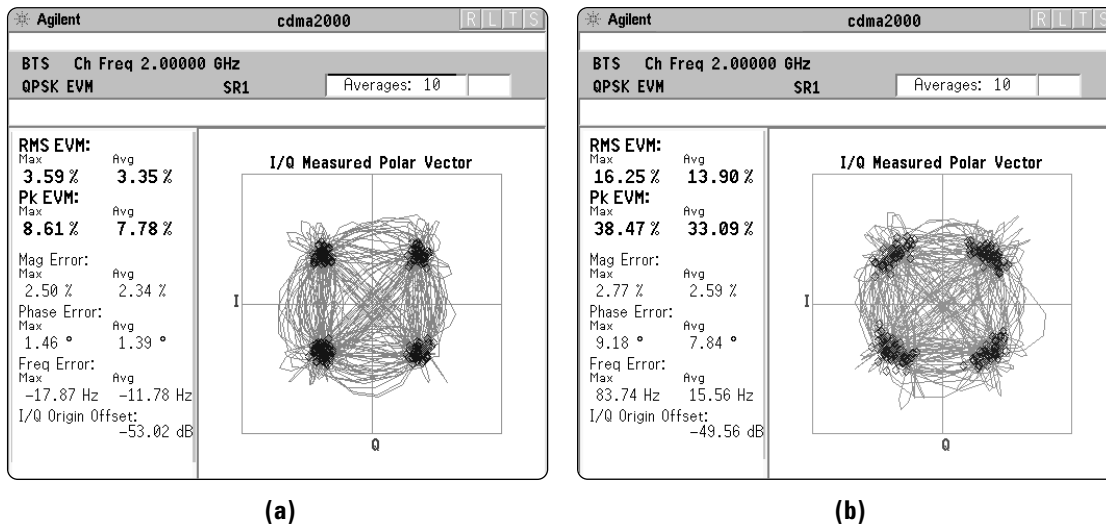

Figure 14. QPSK EVM on a cdma2000 signal (one RC3 traffic channel). (a) Without any impairments, and (b) with a phase noise impairment.

You can use the error vector, magnitude error, and phase error versus time to troubleshoot the impairment. For example, in this case, you could use the phase error versus time display to analyze the interfering signal that is creating the instability in the LO [6].

### 2.2.2 Composite rho

In the IS-2000 standard, as in IS-95, the specified measurement for modulation accuracy is rho. Rho is the ratio of the correlated power to the total power. The correlated power is computed by removing frequency, phase, and time offsets and performing a cross correlation between the corrected signal and an ideal reference.

Rho has traditionally been defined for a pilot-only signal. The measured signal is compared to an ideal version of the pilot signal, as seen in figure 15.

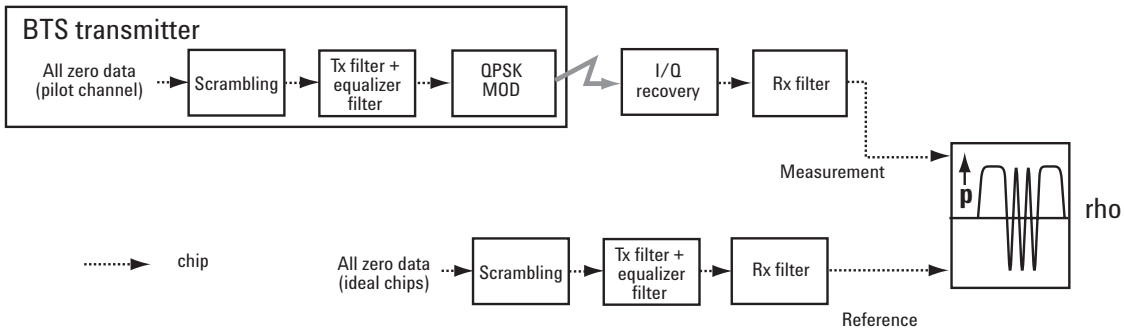
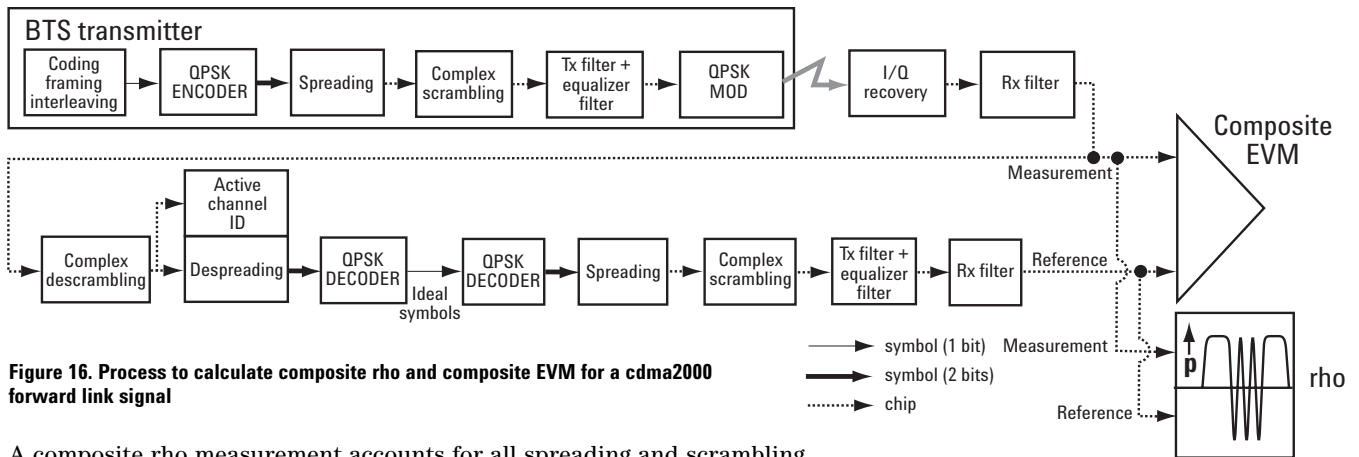

Figure 15. Traditional process to calculate rho for a cdmaOne or cdma2000 SR1 forward link pilot-only signal

As in IS-95, the IS-2000 standards specifies a pilot-only rho conformance test measurement. However, a rho measurement can also be performed on signals with multiple code channels. This measurement is known as composite rho. It allows you to verify the overall modulation accuracy for a transmitter, regardless of the channel configuration, as long as a pilot channel is present. The measurement algorithm involves descrambling and despreading the measured signal to calculate the reference signal, as shown in figure 16.



**Figure 16. Process to calculate composite rho and composite EVM for a cdma2000 forward link signal**

A composite rho measurement accounts for all spreading and scrambling problems in the active channels, and for all baseband, IF and RF impairments in the transmitter chain. However, unless combined with a constellation diagram and other modulation accuracy measurements, rho (or composite rho) does not help you identify the cause of the error. Figures 17a and 17b show composite rho combined with one of these measurements (composite EVM) and the constellation for a single-pilot signal and a multi-channel signal.

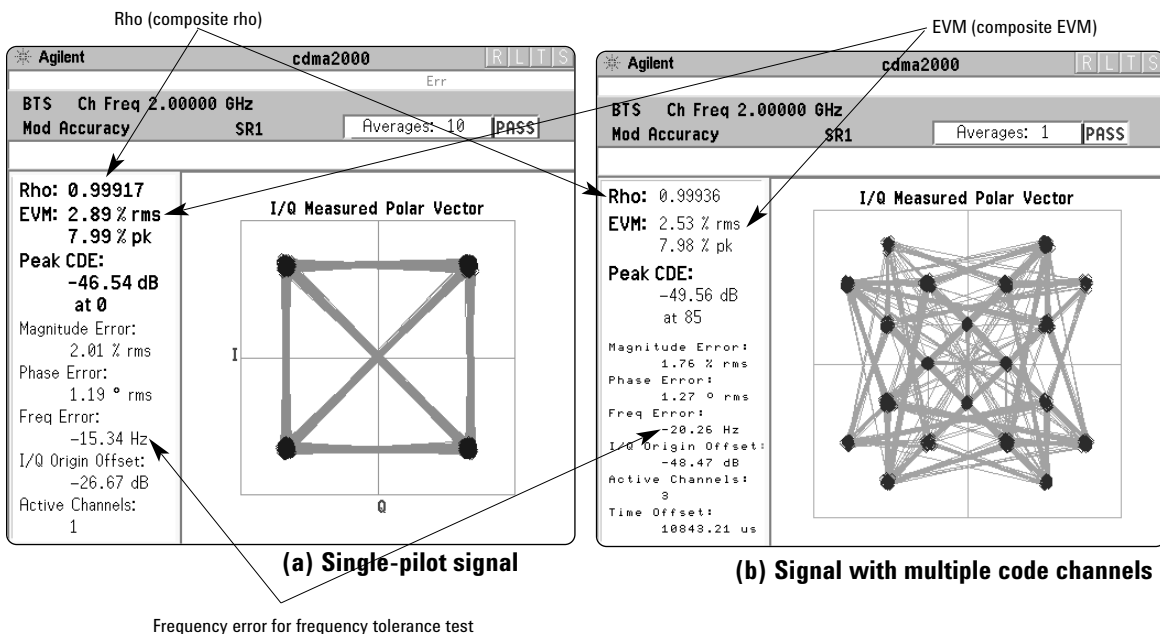

**Figure 17. (a) Composite rho measurement for a cdma2000 SR1 signal with a pilot channel. (b) A cdma2000 SR1 signal with a pilot, sync, and RC3 traffic channel (3 dB lower than the other two channels).**

Like QPSK EVM, composite EVM calculates the error vector difference between the measured and the ideal signal. The difference is that composite EVM uses the same reference as composite rho. That is, it descrambles and despreads the measured signal to calculate the reference (figure 16).

As with IS-95, the IS-2000 standards also require testing for frequency and pilot time tolerance to prevent problems such as "island cell" effects in the deployed network [1]. The frequency error can be obtained when performing a composite rho measurement, as shown in figure 17. The pilot time tolerance is typically provided as one of the error metrics when performing a code domain power measurement (see figure 21).

Here are some situations in which you should use composite rho (and composite error vector measurements) instead of a QPSK EVM measurement:

- **To evaluate the quality of the transmitter for a multi-channel signal.** This is particularly important for RF designers who need to test the RF section (or components) of the transmitter using realistic signals with correct statistics. In general, the peak-to-average power ratio of the signal increases as the number of channels increases. By measuring modulation quality on a multi-channel signal, you can analyze the performance of the RF design for cdma2000 signals with different levels of stress (different CCDFs). Evaluating the modulation quality of multi-channel signals is also important for baseband designers, to analyze the performance of multi-board baseband designs. For example, a small timing error in the clock synchronization between channels on different boards can be detected as a decrease in modulation quality.
- **To detect spreading or scrambling errors.** Depending on the degree of the error, the analyzer may show an intermittent unlock condition or may not be able to lock at all when trying to perform a composite rho measurement. These conditions are mainly of interest to system integrators, to determine errors in the spreading and scrambling. Should this problem occur, you can use the QPSK EVM measurement to confirm that the rest of the transmitter is working as expected. If the scrambling or spreading error does not cause an unlock measurement condition, you can use the error vector versus time display to find the problematic chip.
- **To detect certain problems between the baseband and RF sections.** Again, these cases are mainly of interest to system integrators. You may be able to use QPSK EVM measurement to detect some of these problems. For example, LO instability caused by interference from digital signals can be detected with QPSK EVM, as seen earlier. However, the QPSK EVM measurement will not detect problems that require synchronization. For example, I/Q swapped errors will look perfectly normal if a QPSK EVM measurement is used. On the other hand, it will cause an unlock condition when performing a composite rho measurement.
- **To analyze errors that cause high interference in the signal.** If the interference is too high, the QPSK EVM measurement may not be able to recover the true ideal reference. In this case, the QPSK EVM and its related displays are not accurate. Since the composite rho measurement descrambles and despreads the signal, it takes advantage of its processing gain. This allows the analyzer to recover the true reference even when the signal is well beyond the interference level that will cause multiple chip errors. Therefore, composite rho and composite EVM are true indicators of modulation fidelity even when the signal under test is buried by interference. In this sense, these measurements may be particularly useful in hostile field environments with high levels of interference. R&D engineers can use the measurements to analyze how the interference will affect BTS service deployment and to provide BTS-to-MS sensitivity curves for the providers. (For instance, how bad the EVM can get before the MS or signal analyzer cannot recover the signal.) The processing gain benefits of composite rho (or EVM) can also be useful to RF designers and system integrators for occasional bad cases of interference. For example, figure 18a shows the phase error versus time for a QPSK EVM measurement and figure 18b shows the phase error versus time for a composite rho (or EVM) measurement, for a pilot-only signal with a very high LO instability. In this case, the analyzer can demodulate the signal and calculate the reference accurately. The phase error display in figure 18b will allow you to analyze the interference.

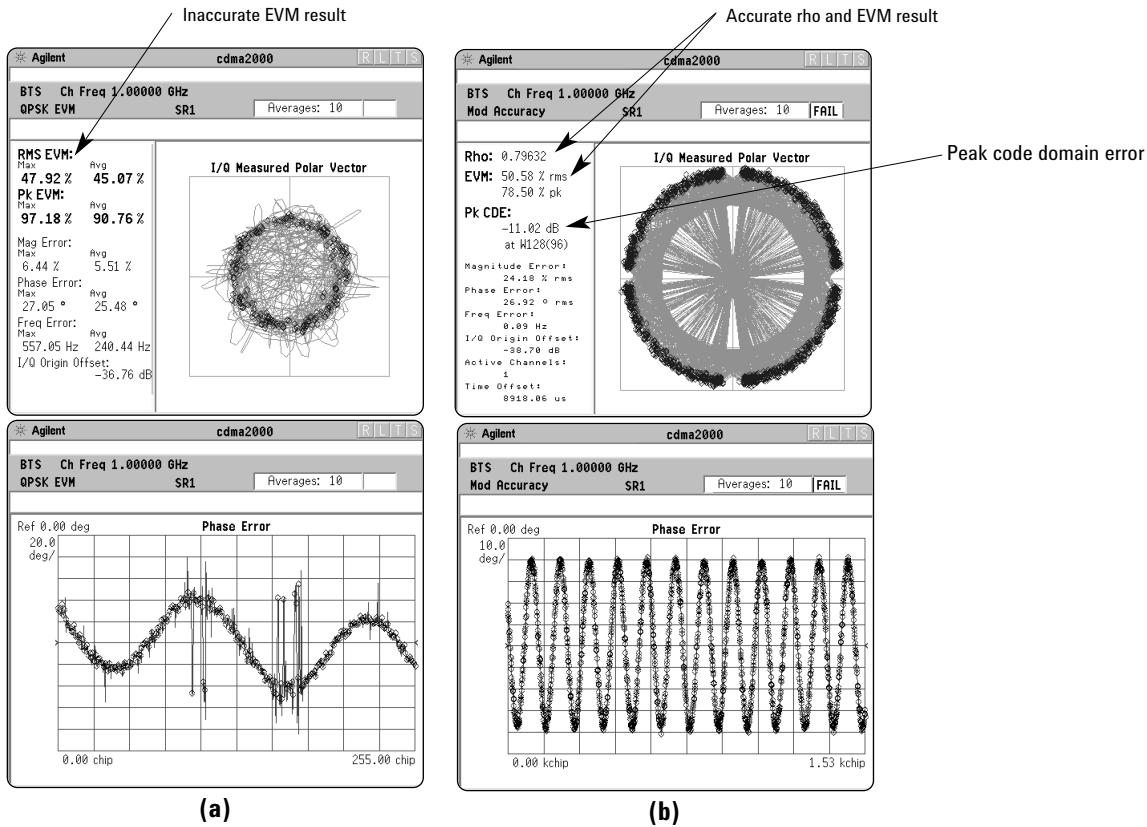

**Figure 18. cdma2000 pilot signal with very high LO instability. (a) Vector diagram and phase error versus time for QPSK EVM. (b) Vector diagram and phase error versus time for composite EVM (provided with composite rho measurement).**

Composite rho is useful throughout the development, performance verification, manufacturing, and installation phases of the BTS life cycle as a figure of merit for the code multiplex as a whole. However, we are also interested in the code-by-code composition of the composite signal. The primary means of investigating this is to look at the distribution of power in the code domain.

### 2.2.3 Code domain power

The other indicator of modulation quality in CDMA systems is code domain power. Using this measurement, you can verify that each Walsh channel is operating at its proper level and can quantify the inactive traffic noise level.

In cdma2000, the measurement is complicated by the fact that the length of the Walsh codes varies to accommodate the different data rates and SRs of the different RCs. In general, as the data rate increases, the symbol period is shorter. For a specific SR, the final chip rate is constant. Therefore, fewer Walsh code chips are accommodated within the symbol period (the Walsh code length is shorter). Table 1 shows the Walsh code length versus bit rate for the different RCs that operate at SR1.

**Table 1. Walsh code length for different RCs at SR1**

RC	Walsh code length					
	128 bits (Walsh 128)	64 bits (Walsh 64)	32 bits (Walsh 32)	16 bits (Walsh 16)	8 bits (Walsh 8)	4 bits (Walsh 4)
1	N/A	9.6 kbps	N/A	N/A	N/A	N/A
2	N/A	14.4 kbps	N/A	N/A	N/A	N/A
3	N/A	9.6 kbps	19.2 kbps	38.4 kbps	76.8 kbps	153.6 kbps
4	9.6 kbps	19.2 kbps	38.4 kbps	76.8 kbps	153.6 kbps	307.2 kbps
5	N/A	14.4 kbps	28.8 kbps	57.6 kbps	115.2 kbps	230.4 kbps

One effect of using variable length Walsh codes for spreading is that a shorter code precludes using all longer codes derived from it. Figure 19 illustrates this concept. If a high data rate channel using a 4-bit Walsh code such as 1,1,-1,-1 is transmitted, all lower data rate channels using longer Walsh codes that start with 1,1,-1,-1 must be inactive to avoid conflicts in the correlation process at the receiver.

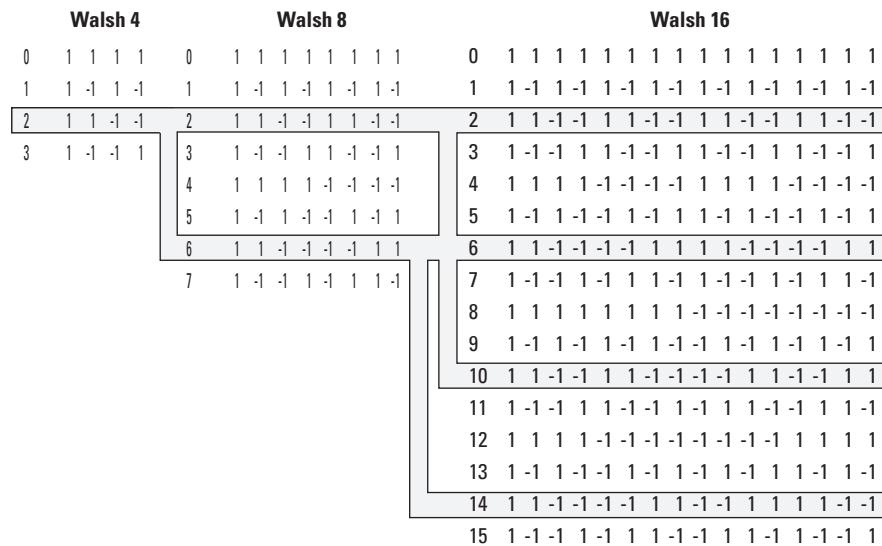

**Figure 19. Hadamard generation of Walsh codes and the effects of using variable length Walsh codes for spreading**

Individual Walsh codes (or functions) are identified by  $W_n^N$ , where N is the length of the code and n is the row in the N x N Hadamard matrix. For example,  $W_2^4$  represents code 2 of the 4 x 4 Hadamard matrix (4-bit Walsh code).

Therefore,  $W_2^4$  precludes using:

- $W_2^8$  and  $W_6^8$ ;
- $W_2^{16}$ ,  $W_6^{16}$ ,  $W_{10}^{16}$ ,  $W_{14}^{16}$ ;
- $W_2^{32}$ ,  $W_6^{32}$ ,  $W_{10}^{32}$ ,  $W_{14}^{32}$ ,  $W_{18}^{32}$ ,  $W_{22}^{32}$ ,  $W_{26}^{32}$ ,  $W_{30}^{32}$  (not shown in figure 20); etc.

Appendix A contains a cdma2000 Walsh code table that shows the relationship among Walsh codes of different lengths (determined by the data rate in a specific RC).

In the code domain power measurement, channels with higher data rates (shorter code lengths) occupy more code space. For example,  $W_2^4$  occupies 4 times more code space than  $W_2^{16}$ , and 16 times more code space than  $W_2^{64}$ . The measurement should provide some way to identify the different layers (Walsh code lengths) of the code channels being measured.

You can use an instrument with cdmaOne capability to make code domain power measurements on SR1 cdma2000 signals, taking some considerations into account. For an SR1 channel with a Walsh code length different from cdmaOne – that is, a channel with a Walsh code shorter than 64 bits<sup>1</sup> – the detected power is spread onto all the Walsh 64 channels with a related Walsh code (a code that starts with the same sequence). Figure 20a shows the actual power levels for a cdma2000 signal with pilot, paging, and sync channels and an RC3 F-SCH with a data rate of 76.8 kbps ( $W_4^8$ ). Figure 20b shows the code domain power measurement on the same signal. The power in  $W_4^8$  is spread among  $W_2^{64}$ ,  $W_{12}^{64}$ ,  $W_{20}^{64}$ ,  $W_{28}^{64}$ ,  $W_{36}^{64}$ ,  $W_{44}^{64}$ ,  $W_{52}^{64}$  and  $W_{60}^{64}$ . (You can use the cdma2000 Walsh code table in Appendix A to see the relationship among Walsh codes of different lengths.) The total computed power of  $W_4^8$  in the code domain power measurement can be calculated by adding the indicated power levels (in linear units) of all related Walsh 64 channels.

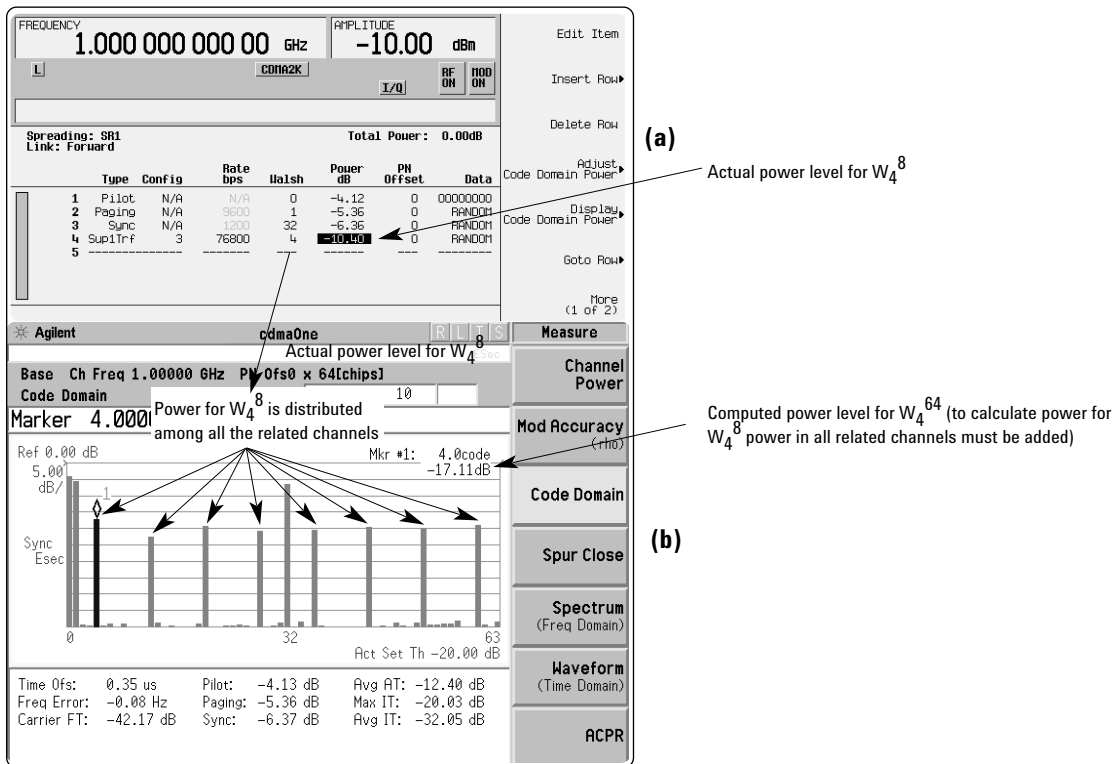

**Figure 20. (a) Signal generation, and (b) Code domain power for a cdma2000 signal with the pilot, paging, sync, and an RC3 (76.8 kbps) F-SCH ( $W_4^8$ ). Measurement performed with an instrument with code domain power capability for cdmaOne.**

1. RC4 (9.6 kbps) is an exception to this. It is the only RC at SR1 that uses Walsh codes longer than 64 bits.

The only case where the code length of a cdma2000 SR1 channel is longer than 64 bits is for RC4 and a data rate of 9.6 kbps. The energy of a 128-bit code will also map onto the related 64-bit code (in this case, the code that it originates from). For example,  $W_{84}^{128}$  will map its energy onto  $W_{20}^{64}$  (see the Walsh code table in appendix A). On the other hand,  $W_{20}^{128}$  will also map its energy onto  $W_{20}^{64}$ . If you use a cdmaOne measurement, you will not be able to calculate the power for each of these two codes separately.

Therefore, a cdmaOne code domain power measurement provides restricted measurement capabilities on SR1 cdma2000 signals. In addition, when multiple code channels with different data rates are active, the measurement process can become tedious.

In any case, an instrument with specific cdma2000 capabilities offers many advantages, such as fast identification of channels with different data rates and accurate power readings for all channels. Figure 21 shows an example of a cdma2000 SR1 code domain power measurement (performed with an instrument with cdma2000 code domain power capability) for the same signal used in figure 20. In this case, the marker identifies the true power for code channel  $W_4^8$  and identifies the code space occupied by this channel distributed in a 64-Walsh Hadamard matrix.

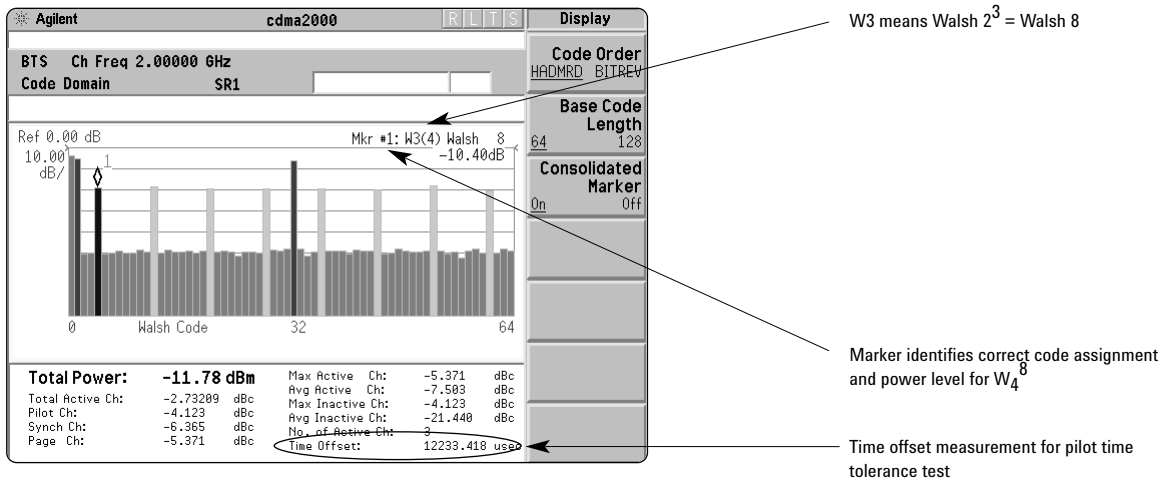

**Figure 21. Code domain power measurement of a cdma2000 signal with the pilot, paging, sync, and an RC3 (76.8 kbps) F-SCH ( $W_4^8$ ) performed with cdma2000 code domain measurement**

Another way to look at the same signal is to reorder the code channels so that related code channels are adjacent to each other. The so-called bit-reverse generation of Walsh codes provides us with this desired code number assignment. This is the code generation method used in W-CDMA [4]. The codes derived from this method are called orthogonal variable spreading factor (OVSF) codes, as opposed to Walsh codes, in W-CDMA. OVSF codes and Walsh codes are the same, only their code number assignment is different. The generation method is called “bit-reverse” because the code number in binary form is reversed (MSB is LSB, etc.), relative to the Hadamard method. For example, code channel 3 (binary: 011) in the Hadamard Walsh 8 matrix corresponds to code channel 6 (binary: 110) in the reverse-bit Walsh 8 matrix, as seen in figure 22.

Hadamard (Walsh codes)				Bit-reverse (OVSF codes)					
Actual code (Walsh 8)		Code number		Actual code (Walsh 8)		Code number			
		In decimal	In binary			In decimal	In binary		
1	1	1	1	1	1	1	1	0	000
1	0	1	0	1	0	1	0	1	001
1	1	0	0	1	1	0	0	2	010
1	0	0	1	1	0	0	1	3	011
1	1	1	1	0	0	0	0	4	100
1	0	1	0	0	1	0	1	5	101
1	1	0	0	0	0	1	1	6	110
1	0	0	1	0	1	1	0	7	111

Figure 22. Hadamard versus bit-reverse

Figure 23 shows the signal from figures 20 and 21 displayed using bit-reverse order. The different channels at different data rates are easily identified using this display. High data rate channels are displayed as "wide" channels, since they occupy more code space.

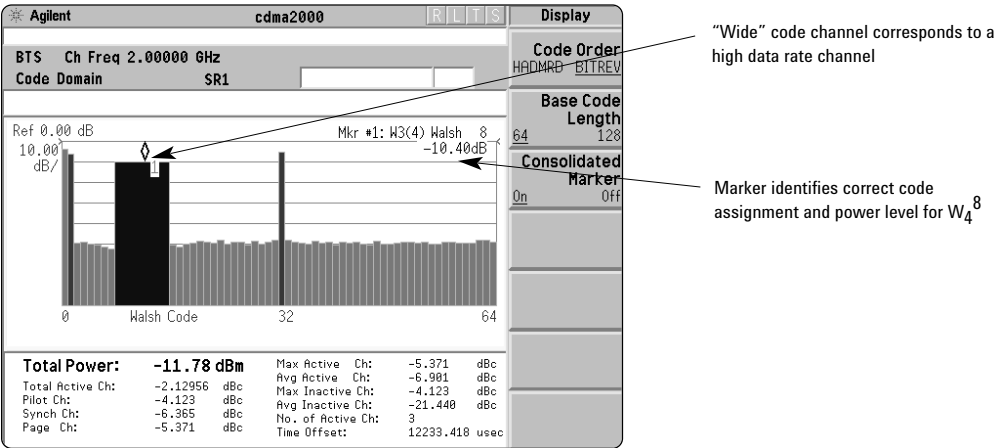

Figure 23. cdma2000 code domain power measurement with bit-reverse display for a signal with the pilot, paging, sync, and an RC3 (76.8 kbps) F-SCH ( $W_4^8$ )

To cover all RCs at all data rates, it is necessary to be able to look at the energy projected in the 128-code space. Figure 24 shows the code domain power measurement of a signal with a pilot, paging, sync, and a RC4 F-FCH ( $W_{84}^{128}$ ) at 9.6 kbps.

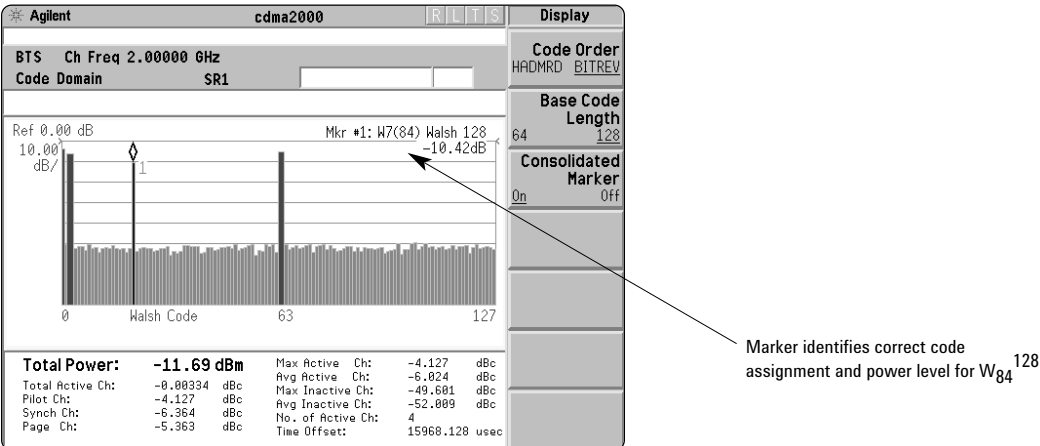
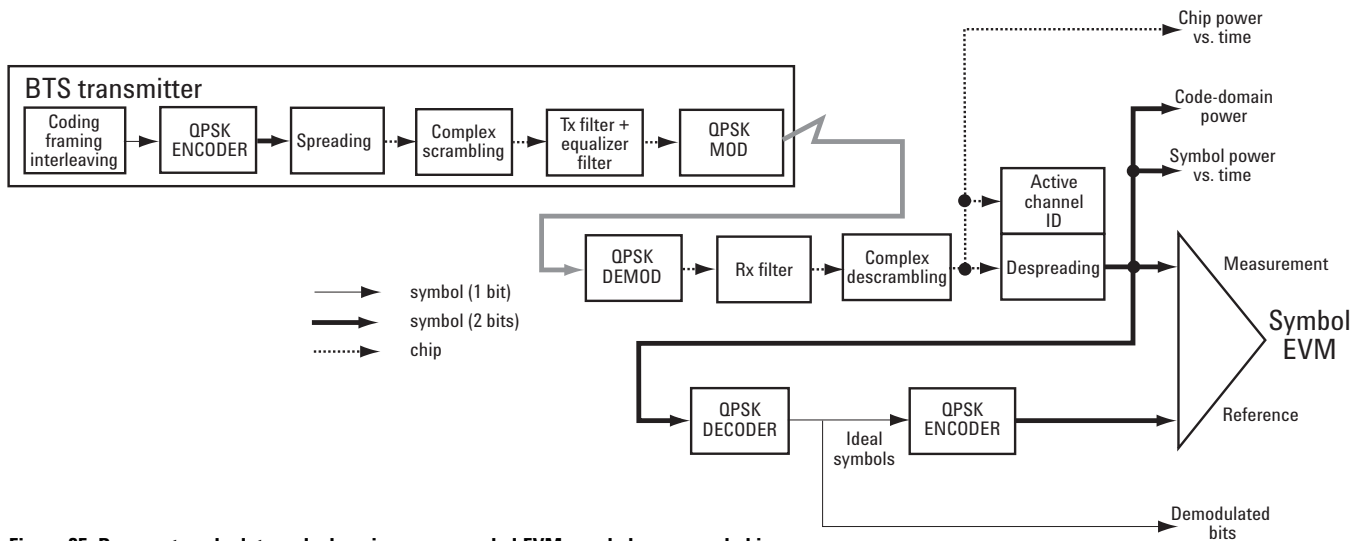

Figure 24. Code domain power measurement with bit-reverse display for a cdma2000 SR1 signal with a pilot, paging, sync, and a RC4 F-FCH ( $W_{84}^{128}$ ). Energy projected in the 128-code space.

The code domain power measurement helps you not only verify that each Walsh channel is operating at its proper level, but also helps identify problems throughout the transmitter design, from the coding to the RF section. In particular, the level of the inactive channels can provide useful information about specific impairments [6]. The projection of the error signal over the code domain, known as code domain error, is of even more interest. You want the error power to be distributed through the code domain, rather than concentrated in a few codes, to avoid code-dependent channel quality variations. However, many transmitter impairments, such as amplifier compression and LO instability, cause uneven distribution of the error throughout the code domain. In these cases, energy is lost from the active channels and appears in related code channels in deterministic ways [8]. For this reason, it is useful to ensure that the code domain error is under a certain limit. The peak code domain error measurement (shown in figure 18b in combination with a composite rho measurement) indicates the maximum code domain error in the signal and to which code channel this error belongs.

Related to code domain power, cdmaOne standards specify a pilot channel to code channel time tolerance and pilot channel to code channel phase tolerance [1]. These tests will probably be part of the IS-2000 standard. However, they are irrelevant if digital summing is used, since digital summing prevents delays and phase shifts between channels.

Apart from looking at the code domain power, it is useful to analyze a specific code channel. The following sections describe some analysis tools and their applications. Figure 25 shows how the references for these measurements are calculated.



**Figure 25. Process to calculate code domain power, symbol EVM, symbol power and chip power versus time, and the demodulated bits for a cdma2000 forward link signal**

## 2.2.4 Symbol EVM

By descrambling and despreading the signal, you can analyze the constellation for a specific code channel at the symbol level, even in the presence of multiple code channels. The measured signal is complex descrambled, despread, and QPSK decoded to one-bit symbols. The ideal one-bit symbols are then QPSK encoded to obtain the reference at the symbol level. This reference is then compared to the measured despread two-bit symbols (figure 25).

An RF impairment that affects symbol EVM will also affect the composite EVM. For example, an amplifier compression problem will appear both in the composite EVM and in the symbol EVM measurement. However, because of the processing gain, symbol EVM will mute the impairment. So, why use symbol EVM?

Symbol EVM provides the bridge between RF and the demodulated bits. Since it includes the processing gain, it provides baseband engineers a measure of modulation quality closer to real-life performance. In this sense, you can think of it as the actual quality that the user in that channel will experience (similar to the reciprocal of bit error rate (BER)).

Symbol EVM is important in cdma2000 because the Walsh code length varies. Therefore, there is a compromise between the data rate and the modulation quality. A chip error in a symbol for a higher data rate channel (less processing gain) will result in poorer modulation quality (higher BER) when compared to a chip error in a symbol for a lower data rate channel, if both channels use the same amplitude level. In that sense, it is particularly useful to baseband DSP engineers to analyze how the different impairments affect the quality of channels at different data rates. For example, figure 26 shows the cdma2000 code domain power measurement (bit-reverse display) for a signal with a pilot, paging, sync, one RC3 F-FCH ( $W_9^{64}$  at 9.6 kbps<sup>1</sup>), and one RC3 F-SCH ( $W_4^8$  at 76.8 kbps<sup>2</sup>). The signal suffers from high frequency LO interference. LO interference does not raise the level of the code domain power noise floor evenly for all channels. Instead, it raises the power of some inactive channels (those which are mathematically related to the active channels) more than others [6]. Figure 26a shows the constellation and symbol EVM (around 15 percent) for the lower data rate ( $W_9^{64}$ ) channel. On the other hand, the higher data rate channel ( $W_4^8$ ) suffers from a higher symbol EVM (around 25 percent).

---

1. A bit rate of 9.6 kbps at RC3 corresponds to a symbol (one-bit) rate of 19.2 ksps after coding and interleaving.

2. A bit rate of 76.8 kbps at RC3 corresponds to a symbol (one-bit) rate of 153.6 ksps after coding and interleaving.

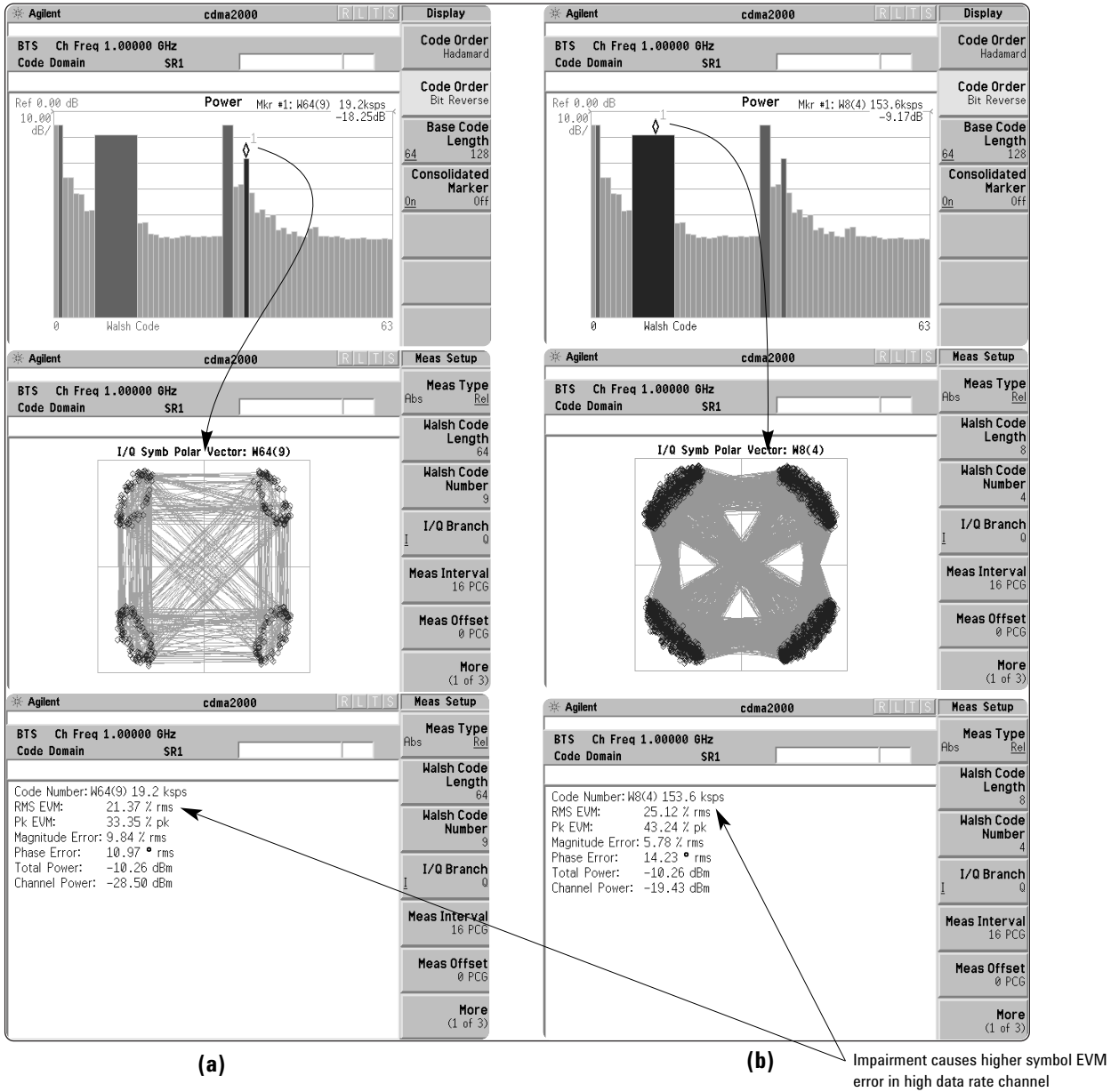

**Figure 26. cdma2000 code domain power measurement (bit-reverse display) for a signal with a pilot, paging, sync, one RC3 F-FCH ( $W_6^{64}$ ), and one RC3 F-SCH ( $W_4^8$ ). Signal with a high frequency LO interference problem: (a) symbol EVM measurement for the F-FCH, and (b) symbol EVM measurement for the F-SCH.**

### 2.2.5 Symbol power versus time

Analyzing the power for a specific code channel versus time (or versus symbol) can be particularly useful to monitor the power and response of the BTS power control system. For example, figure 27 shows a symbol power increase of 0.5 dB in the  $W_9^{64}$  F-FCH (for the same signal used in figure 26), but with no impairments.

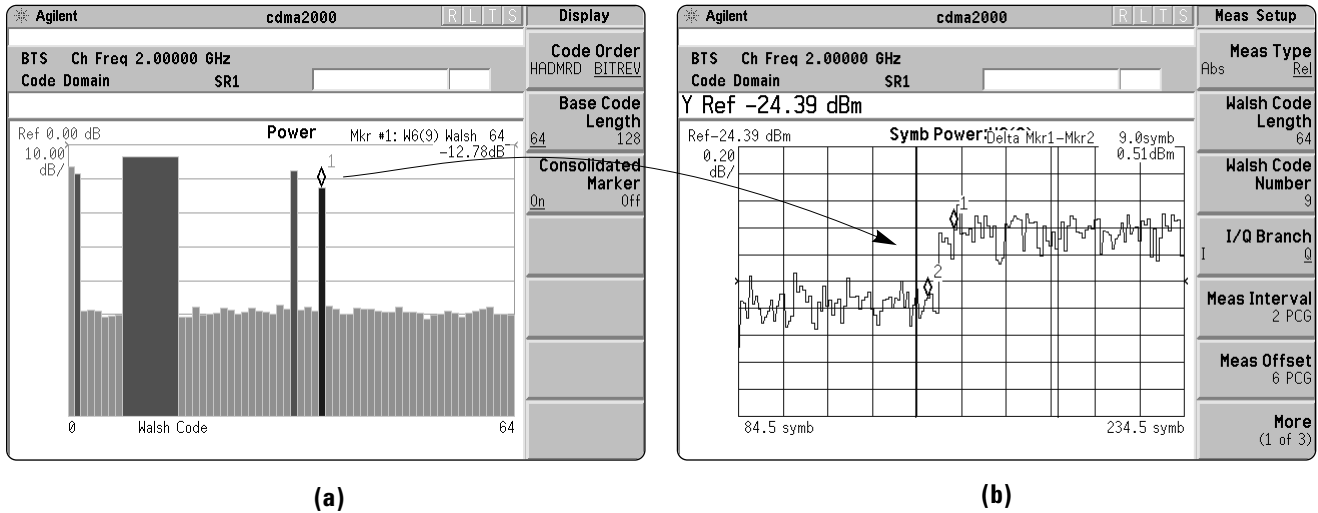

Figure 27. (a) cdma2000 code domain power measurement (bit-reverse display) for a signal with a pilot, paging, sync, one RC3 F-FCH ( $W_9^{64}$ ), and one RC3 F-SCH ( $W_4^8$ ). (b) Symbol power versus time for the F-FCH.

Figure 28 shows the symbol power versus time in combination with the chip power for the signal versus time. This is particularly useful for system integrators for analyzing the power amplifier response (ripple) to a series of power control commands.

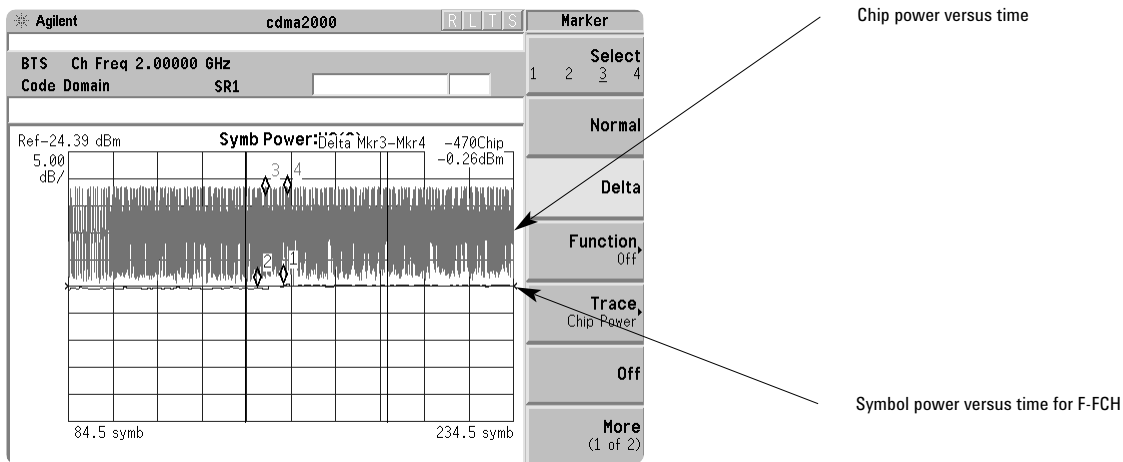
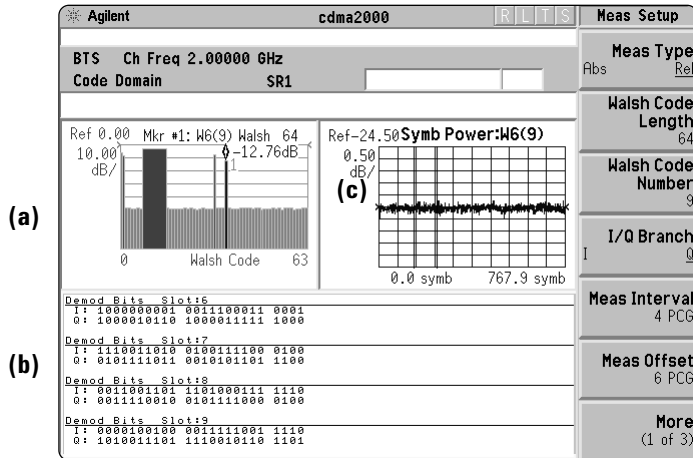

Figure 28. Chip power versus time for a signal with a pilot, paging, sync, one RC3 F-FCH ( $W_9^{64}$ ), and one RC3 F-SCH ( $W_4^8$ ), combined with symbol power versus time for the F-FCH

## 2.2.6 Demodulated bits

Figure 29 shows the I and Q demodulated bits (symbols before de-interleaving and decoding) for the F-FCH of a cdma2000 signal. By obtaining the demodulated symbols after descrambling and despreading for each code channel, the correct symbol patterns can be verified. This is particularly important for the power control bits, since power control is absolutely critical to system performance.



**Figure 29. (a) cdma2000 code domain power measurement (bit-reverse display) for a signal with a pilot, paging, sync, one RC3 F-FCH ( $W_9^{64}$ ), and one RC3 F-SCH ( $W_4^8$ ). (b) Demodulated bits for the F-FCH. (c) Symbol power versus time for the F-FCH.**

Demodulated bits is an important troubleshooting tool for baseband engineers to identify coding, interleaving, and power control bit errors. In many cases, it can help clarify situations where the BTS and MS are having problems communicating with each other. Analyzing the demodulated symbols may confirm whether the error is coming from the BTS coding and interleaving or the MS de-interleaving and de-coding process.

# Appendix A: cdma2000 Walsh code table

This table shows the relationship between Walsh codes of different lengths for the different RCs at different data rates. The energy in a channel with a shorter code correlates into all channels with longer related codes.

Therefore, a shorter code precludes using all longer codes derived from it (from right to left, in the table). For example, RC3 at 76.8 kbps uses Walsh 8 codes.  $W_4^8$  precludes using:

- $W_4^{16}$  and  $W_{12}^{16}$ ,
- $W_4^{32}$ ,  $W_{12}^{32}$ ,  $W_{20}^{32}$ ,  $W_{28}^{32}$ ,
- $W_4^{64}$ ,  $W_{12}^{64}$ ,  $W_{20}^{64}$ ,  $W_{28}^{64}$ ,  $W_{36}^{64}$ ,  $W_{44}^{64}$ ,  $W_{52}^{64}$ ,  $W_{60}^{64}$
- etc.

Spread rate		cdma2000 Walsh code table						
RC								
1.2288 Mcps	1	N/A	N/A	9.6 kbps	N/A	N/A	N/A	N/A
1.2288 Mcps	2	N/A	N/A	14.4 kbps	N/A	N/A	N/A	N/A
1.2288 Mcps	3	N/A	N/A	9.6 kbps	19.2 kbps	38.4 kbps	76.8 kbps	153.6 kbps
1.2288 Mcps	4	N/A	N/A	9.6 kbps	19.2 kbps	38.4 kbps	76.8 kbps	153.6 kbps
1.2288 Mcps	5	N/A	N/A	14.4 kbps	28.8 kbps	57.6 kbps	115.2 kbps	230.4 kbps
3.6864 Mcps	6	N/A	9.6 kbps	19.2 kbps	38.4 kbps	76.8 kbps	153.6 kbps	307.2 kbps
3.6864 Mcps	7	9.6 kbps	19.2 kbps	38.4 kbps	76.8 kbps	153.6 kbps	307.2 kbps	614.4 kbps
3.6864 Mcps	8	N/A	14.4 kbps	28.8 kbps	57.6 kbps	115.2 kbps	230.4 kbps	460.8 kbps
3.6864 Mcps	9	14.4 kbps	28.8 kbps	57.6 kbps	115.2 kbps	230.4 kbps	460.8 kbps	921.6 kbps
		Walsh 256	Walsh 128	Walsh 64	Walsh 32	Walsh 16	Walsh 8	Walsh 4
		0	0	0	0	0	0	0
		128						
		64	64					
		192						
		32	32					
		120	120					
		248						
		4	4	4	4	4	4	
		132						
		68	68					
		196						
		36	36	36				
		164						
		100	100					
		228						
		20	20	20	20			
		148						
		84	84					
		212						
		52	52					
		180						
		116	116					
		244						
		12	12	12	12	12		
		140						
		76	76					
		204						
		44	44					
		172						
		108	108					
		236						
		28	28	28	28			
		156						
		92	92					
		220						
		60	60	60				
		188						
		124	124					
		252						

Figure 30. Using  $W_4^8$  precludes using the codes in the shaded area

Spread rate RC		cdma2000 Walsh code table						
1.2288 Mcps	1	N/A	N/A	9.6 kbps	N/A	N/A	N/A	N/A
1.2288 Mcps	2	N/A	N/A	14.4 kbps	N/A	N/A	N/A	N/A
1.2288 Mcps	3	N/A	N/A	9.6 kbps	19.2 kbps	38.4 kbps	76.8 kbps	153.6 kbps
1.2288 Mcps	4	N/A	9.6 kbps	19.2 kbps	38.4 kbps	76.8 kbps	153.6 kbps	307.2 kbps
1.2288 Mcps	5	N/A	N/A	14.4 kbps	28.8 kbps	57.6 kbps	115.2 kbps	230.4 kbps
3.6864 Mcps	6	N/A	9.6 kbps	19.2 kbps	38.4 kbps	76.8 kbps	153.6 kbps	307.2 kbps
3.6864 Mcps	7	9.6 kbps	19.2 kbps	38.4 kbps	76.8 kbps	153.6 kbps	307.2 kbps	614.4 kbps
3.6864 Mcps	8	N/A	14.4 kbps	28.8 kbps	57.6 kbps	115.2 kbps	230.4 kbps	460.8 kbps
3.6864 Mcps	9	14.4 kbps	28.8 kbps	57.6 kbps	115.2 kbps	230.4 kbps	460.8 kbps	1036.8 kbps
		Walsh 256	Walsh 128	Walsh 64	Walsh 32	Walsh 16	Walsh 8	Walsh 4
		0	0	0	0	0	0	0
		128						
		64	64					
		192						
		32	32	32				
		160						
		96	96					
		224						
		16	16	16	16			
		144						
		80	80					
		208						
		48	48	48				
		176						
		112	112					
		240						
		8	8	8	8	8		
		136						
		72	72					
		200						
		40	40	40				
		168						
		104	104					
		232						
		24	24	24	24			
		152						
		88	88					
		216						
		56	56	56				
		184						
		120	120					
		248						
		4	4	4	4	4	4	
		132						
		68	68					
		196						
		36	36	36				
		164						
		100	100					
		228						
		20	20	20	20			
		148						
		84	84					
		212						
		52	52	52				
		180						
		116	116					
		244						
		12	12	12	12	12		
		140						
		76	76					
		204						
		44	44	44				
		172						
		108	108					
		236						
		28	28	28	28			
		156						
		92	92					
		220						
		60	60	60				
		188						
		124	124					
		252						

Spread rate RC		cdma2000 Walsh code table						
1.2288 Mcps	1	N/A	N/A	9.6 kbps	N/A	N/A	N/A	N/A
1.2288 Mcps	2	N/A	N/A	14.4 kbps	N/A	N/A	N/A	N/A
1.2288 Mcps	3	N/A	N/A	9.6 kbps	19.2 kbps	38.4 kbps	76.8 kbps	153.6 kbps
1.2288 Mcps	4	N/A	9.6 kbps	19.2 kbps	38.4 kbps	76.8 kbps	153.6 kbps	307.2 kbps
1.2288 Mcps	5	N/A	N/A	14.4 kbps	28.8 kbps	57.6 kbps	115.2 kbps	230.4 kbps
3.6864 Mcps	6	N/A	9.6 kbps	19.2 kbps	38.4 kbps	76.8 kbps	153.6 kbps	307.2 kbps
3.6864 Mcps	7	9.6 kbps	19.2 kbps	38.4 kbps	76.8 kbps	153.6 kbps	307.2 kbps	614.4 kbps
3.6864 Mcps	8	N/A	14.4 kbps	28.8 kbps	57.6 kbps	115.2 kbps	230.4 kbps	460.8 kbps
3.6864 Mcps	9	14.4 kbps	28.8 kbps	57.6 kbps	115.2 kbps	230.4 kbps	460.8 kbps	1036.8 kbps
		Walsh 256	Walsh 128	Walsh 64	Walsh 32	Walsh 16	Walsh 8	Walsh 4
		1	1	1	1	1	1	1
		129						
		65	65					
		193						
		33	33	33				
		161						
		97	97					
		225						
		17	17	17	17			
		145						
		81	81					
		209						
		49	49	49				
		177						
		113	113					
		241						
		9	9	9	9	9		
		137						
		73	73					
		201						
		41	41	41				
		169						
		105	105					
		233						
		25	25	25	25			
		153						
		89	89					
		217						
		57	57	57				
		185						
		121	121					
		249						
		5	5	5	5	5	5	
		133						
		69	69					
		197						
		37	37	37				
		165						
		101	101					
		229						
		21	21	21	21			
		149						
		85	85					
		213						
		53	53	53				
		181						
		117	117					
		245						
		13	13	13	13	13		
		141						
		77	77					
		205						
		45	45	45				
		173						
		109	109					
		237						
		29	29	29	29			
		157						
		93	93					
		221						
		61	61	61				
		189						
		125	125					
		253						

Spread rate RC		cdma2000 Walsh code table						
1.2288 Mcps	1	N/A	N/A	9.6 kbps	N/A	N/A	N/A	N/A
1.2288 Mcps	2	N/A	N/A	14.4 kbps	N/A	N/A	N/A	N/A
1.2288 Mcps	3	N/A	N/A	9.6 kbps	19.2 kbps	38.4 kbps	76.8 kbps	153.6 kbps
1.2288 Mcps	4	N/A	9.6 kbps	19.2 kbps	38.4 kbps	76.8 kbps	153.6 kbps	307.2 kbps
1.2288 Mcps	5	N/A	N/A	14.4 kbps	28.8 kbps	57.6 kbps	115.2 kbps	230.4 kbps
3.6864 Mcps	6	N/A	9.6 kbps	19.2 kbps	38.4 kbps	76.8 kbps	153.6 kbps	307.2 kbps
3.6864 Mcps	7	9.6 kbps	19.2 kbps	38.4 kbps	76.8 kbps	153.6 kbps	307.2 kbps	614.4 kbps
3.6864 Mcps	8	N/A	14.4 kbps	28.8 kbps	57.6 kbps	115.2 kbps	230.4 kbps	460.8 kbps
3.6864 Mcps	9	14.4 kbps	28.8 kbps	57.6 kbps	115.2 kbps	230.4 kbps	460.8 kbps	1036.8 kbps
		Walsh 256	Walsh 128	Walsh 64	Walsh 32	Walsh 16	Walsh 8	Walsh 4
		2	2	2	2	2	2	2
		130						
		66	66					
		194						
		34	34	34				
		162						
		98	98					
		226						
		18	18	18	18			
		146						
		82	82					
		210						
		50	50	50				
		178						
		114	114					
		242						
		10	10	10	10	10		
		138						
		74	74					
		202						
		42	42	42				
		170						
		106	106					
		234						
		26	26	26	26			
		154						
		90	90					
		218						
		58	58	58				
		186						
		122	122					
		250						
		6	6	6	6	6	6	
		134						
		70	70					
		198						
		38	38	38				
		166						
		102	102					
		230						
		22	22	22	22			
		150						
		86	86					
		214						
		54	54	54				
		182						
		118	118					
		246						
		14	14	14	14	14		
		142						
		78	78					
		206						
		46	46	46				
		174						
		110	110					
		238						
		30	30	30	30			
		158						
		94	94					
		222						
		62	62	62				
		190						
		126	126					
		254						

Spread rate		cdma2000 Walsh code table						
RC								
1.2288 Mcps	1	N/A	N/A	9.6 kbps	N/A	N/A	N/A	N/A
1.2288 Mcps	2	N/A	N/A	14.4 kbps	N/A	N/A	N/A	N/A
1.2288 Mcps	3	N/A	N/A	9.6 kbps	19.2 kbps	38.4 kbps	76.8 kbps	153.6 kbps
1.2288 Mcps	4	N/A	9.6 kbps	19.2 kbps	38.4 kbps	76.8 kbps	153.6 kbps	307.2 kbps
1.2288 Mcps	5	N/A	N/A	14.4 kbps	28.8 kbps	57.6 kbps	115.2 kbps	230.4 kbps
3.6864 Mcps	6	N/A	9.6 kbps	19.2 kbps	38.4 kbps	76.8 kbps	153.6 kbps	307.2 kbps
3.6864 Mcps	7	9.6 kbps	19.2 kbps	38.4 kbps	76.8 kbps	153.6 kbps	307.2 kbps	614.4 kbps
3.6864 Mcps	8	N/A	14.4 kbps	28.8 kbps	57.6 kbps	115.2 kbps	230.4 kbps	460.8 kbps
3.6864 Mcps	9	14.4 kbps	28.8 kbps	57.6 kbps	115.2 kbps	230.4 kbps	460.8 kbps	1036.8 kbps
		Walsh 256	Walsh 128	Walsh 64	Walsh 32	Walsh 16	Walsh 8	Walsh 4
		3	3	3	3	3	3	3
		131						
		67	67					
		195						
		35	35	35				
		163						
		99	99					
		227						
		19	19	19	19			
		147						
		83	83					
		211						
		51	51	51				
		179						
		115	115					
		243						
		11	11	11	11	11		
		139						
		75	75					
		203						
		43	43	43				
		171						
		107	107					
		235						
		27	27	27	27			
		155						
		91	91					
		219						
		59	59	59				
		187						
		123	123					
		251						
		7	7	7	7	7	7	
		135						
		71	71					
		199						
		39	39	39				
		167						
		103	103					
		231						
		23	23	23	23			
		151						
		87	87					
		215						
		55	55	55				
		183						
		119	119					
		247						
		15	15	15	15	15		
		143						
		79	79					
		207						
		47	47	47				
		175						
		111	111					
		239						
		31	31	31	31			
		159						
		95	95					
		223						
		63	63	63				
		191						
		127	127					
		255						

# Appendix B: Agilent solutions for cdma2000 BTS design and test

This section provides a list of Agilent solutions that can help develop and test your cdma2000 BTS designs.

## Design software and simulation

The Agilent cdma2000 design library helps ensure successful development of CDMA communications products based on the physical layer specifications in the TIA IS-2000 specifications. With this library, you can design, develop and verify your cdma2000 product in the mixed signal (analog/RF and DSP) environment of Advanced Design System (ADS). Links to Agilent test equipment help you perform quick and consistent hardware verification.

With this library, you can develop and refine algorithms, perform system-level tradeoffs, partition requirements, and verify performance at the system level, where design choices have the greatest impact. You can also include analog/RF circuit design or measured response and quantify the distortions at the system level.

The library includes the following models and application examples:

- rake receivers for both the forward link and the reverse link
- forward link transmissions with SR1 and SR3
- reverse link transmissions with SR1 and SR3
- reverse link with HPSK modulation (SR1 and SR3)
- channel encoding with turbo codes with BER/FER measurement
- measurement of ACPR, CCDF and EVM
- transmission power control for both forward and reverse links
- complete RF transmitter and receiver design capability, including nonlinear components, phase noise, and inter-modulation distortion
- signal source design guide for convenient configuration of cdma2000 sources

The library includes advanced features such as HPSK spreading (reverse link), pilot-aided coherent demodulation (reverse link); channel coding including turbo codes, mapping and de-mapping schemes for rate matching; and orthogonal transmit diversity (OTD).

## Signal generation

The Agilent ESG RF signal generator<sup>1</sup> with the multi-carrier cdma2000 option has the capability of simulating statistically correct forward and reverse link cdma2000 signals for BTS component and subsystem testing. An easy-to-use interface allows you to:

- select the spreading rate (SR1 or SR3)
- select from several predefined cdma2000 multi-channel signals
- use the table editor to fully configure a cdma2000 multi-channel multi-carrier signal per your requirements.

The Agilent ESG RF signal generator with the fully-coded cdma2000 is capable of simulating fully coded cdma2000 signals (SR1) for BTS receiver test. You can conduct frame or bit error tests to verify receiver performance. The cdma2000 personality is backward compatible with IS-95 systems using RC1 or RC2. The key features are:

---

1. The ESG family of RF signal generators consists of many different models to meet your specific signal generation needs. The E4438C is the newest high performance model that meets the demands of cdma2000 signal generation. It combines both the multi-carrier and fully-coded cdma2000 options in a single package.

- Fully coded channels including R-Pilot, R-DCCH, R-FCH and R-SCH channels. Signal-configuration is simplified using the built-in table editor.

Many parameters, including the RC, long code mask, power level for each channel, intersymbol interference (ISI) filter type, and others (depending upon channel type) can be modified.

- R-FCH: Select the data rate, Walsh code, data source (this can be PN9, PN15, any 4-bit pattern, or a user file), and frame offsets 0 to 15.
- R-SCH: Select the data rate, Walsh code, data source (this can be PN9, PN15, any 4-bit pattern, or a user file), frame offsets 0 to 15, and turbocoding.

## Power meters and sensors

The Agilent EPM-P series power meters and E9320 peak and average power sensors provide peak, average and peak-to-average ratio power measurements on cdma2000 signals. Fast test times, with a measurement speed of up to 1,000 corrected readings per second, over the GPIB, help increase throughput to meet time-to-market and time-to-volume goals. The E9320 peak and average power sensors have a maximum video bandwidth of 5 MHz, ideal for cdma2000 power measurements. High power measurements (average only) of up to 25 W (+44 dBm) are available in the E9300 family.

EPM-P analyzer software is provided on a CD-ROM, and is a PC-based tool for pulse and statistical analysis. For cdma2000, statistical analysis of the power distribution provides essential characterization to optimize system design, such as testing for amplifier compression.

Recommended power meters and sensors for cdma2000 peak and average power measurements are:

- EPM-P series power meter E4416A, single channel
- EPM-P series power meter E4417A, dual channel
- E9323A peak and average power sensor, 50 MHz to 6 GHz, 5 MHz video bandwidth, -60 to +20 dBm

All 8480 and E-series power sensors are compatible with the EPM-P series power meters.

For average power measurements only, the lower cost EPM series power meters and other E-series power sensors recommended are:

- EPM series power meter E4418B, single channel
- EPM series power meter, dual channel
- E9301A power sensor, 10 MHz to 6 GHz, -60 to +20 dBm
- E9301H power sensor, 10 MHz to 6 GHz, -50 to +30 dBm
- E9300B power sensor, 10 MHz to 6 GHz, -30 to +44 dBm

Other power sensors in the 8480 series are compatible with the EPM series power meters.

## Power supplies

BTSs are typically powered by 24 or 48 volt DC power systems, with most of the power being drawn by the RF power amplifier. BTS ratings vary from as little as several watts up to many kilowatts of transmit power. A reliable source of clean DC power with adequate protection features is needed during development testing of valuable BTS and power amplifier prototypes. DC power measurement from the power supply is used to determine power added efficiency (PAE). Agilent offers many models of single output DC power supplies suited for BTS and power amplifier development testing.

Model	6653A	6654A	6032A note 1	6673A	6674A	6683A	6684A	6691A	6692A
Power	500 W	500 W	1 kW	1 kW	2 kW	5 kW	5 kW	6.6 kW	6.6 kW
Max V	35 V	60 V	60 V	35 V	60 V	32 V	40 V	30 V	60 V
Max I	15 A	9 A	50 A	60 A	35 A	160 A	128 A	220 A	110 A

Notes :

1. Autoranging topology. Full power from 20 volts to 60 volts.
2. Identical power supplies can be paralleled for higher current and power.
3. Additional volt/amp combinations and power levels are available.

## Signal analysis

This table provides the list of Agilent signal analyzers and their cdma2000 measurement capabilities for BTS transmitter test (as of November 2001).

**Table 2. Agilent signal analysis capabilities for cdma2000 SR1**

cdma2000		Agilent signal analyzers				
		Vector signal analyzers			Spectrum analyzers	
Measurements		E4406A VSA transmitter tester <sup>1</sup>	89400A vector signal analyzer <sup>2</sup>	89600 vector signal analyzer <sup>2</sup>	PSA series spectrum analyzers <sup>1</sup>	ESA-E series spectrum analyzer <sup>2</sup>
Channel power		●	● <sup>4</sup>	● <sup>4</sup>	●	●
Occupied bandwidth		●	● <sup>4</sup>	● <sup>4</sup>	●	●
In-band emissions	ACPR	●	● <sup>4</sup>		●	●
	In-band spurious	●	● <sup>4</sup>		●	● <sup>4</sup>
Out-of-band emissions (spurious/harmonics)					● <sup>6</sup>	● <sup>4</sup>
Peak/average power ratio		●	●	●	●	●
CCDF		●	●	●	●	●
Modulation quality (SR1)	QPSK EVM	●	●	●	●	●
	rho (pilot only)	●	● <sup>5</sup>	●	●	●
	Composite rho and EVM	●		●	●	
	Frequency accuracy	●	●	●	●	●
	Time offset	●			●	●
	Code domain power	●		● <sup>3</sup>	●	● <sup>7</sup>
	Symbol EVM	●		●	●	
	Symbol power vs. time	●		●	●	
	Composite chip power vs. time	●		●	●	
Demodulated bits	●		●	●		

**Notes:**

1. Measurements pre-configured for cdma2000.
2. Some measurements pre-configured for cdma2000 (or cdmaOne). Parameters for other measurements must be set up manually, as indicated.
3. Code domain power with both a composite display and a display for Walsh code set (at each length).
4. Manual measurement (no automatic spurious search or ACPR measurement).
5. There are several interpretations of rho. The 89400 and 89600 vector signal analyzers can make the rho measurement with certain assumptions.
6. Manual measurement.
7. cdmaOne measurement. cdma2000 measurements can be made with certain limitations.

# Instruments used for measurement examples

The measurement examples and screen images in this application note were obtained using the following instruments:

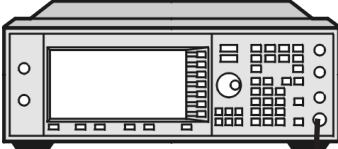

Agilent ESG-D  
series RF digital  
signal generator  
Option 100

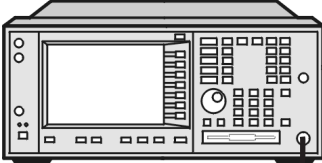

Agilent E4406A  
VSA transmitter tester



## Acronym glossary

2G	Second Generation
3G	Third Generation
3GPP	Third Generation Partnership Project
3GPP2	Third-Generation Partnership Project 2
ACP	Adjacent Channel Power
ACPR	Adjacent Channel Power Ratio
ADS	Advanced Design System
ARIB	Japanese Association of Radio Industries and Businesses
BPSK	Binary Phase Shift Keying
BTS	Base Transceiver Station
CCDF	Complementary Cumulative Distribution Function
CDMA	Code Domain Multiple Access
cdmaOne	Name identifying the EIA/TIA standard (commonly referred to as IS-95) for 2G
cdma2000	Name identifying the EIA/TIA standard (IS-2000) for 3G
CRC	Cyclic Redundancy Check
DS	Direct Sequence
DSP	Digital Signal Processing
EVM	Error Vector Magnitude
F-DCCH	Forward Dedicated Control Channel
F-FCH	Forward Fundamental Channel
FIR	Finite Impulse Response
F-Paging	Forward Paging
F-Pilot	Forward Pilot
F-SCCH	Forward Supplemental Code Channel
F-SCH	Forward Supplemental Channel
F-Sync	Forward Sync
F-Traffic	Forward Traffic
GMSK	Gaussian Minimum Shift Keying
GPS	Global Positioning System
HPSK	Hybrid Phase Shift Keying
IF	Intermediate Frequency
IMT-2000	International Mobile Telecommunications-2000
I/Q	In-phase/Quadrature
IS-2000	EIA/TIA Interim Standard 2000 (see cdma2000)
IS-95	Interim Standard for US Code Division Multiple Access
ISI	Intersymbol Interference
LO	Local Oscillator
LSB	Least Significant Bit
MS	Mobile Station
MSB	Most Significant Bit
OCQPSK	Orthogonal Complex Quadrature Phase Shift Keying
OQPSK	Offset Quadrature Phase Shift Keying
OTD	Orthogonal Transmit Diversity
OVSF	Orthogonal Variable Spreading Factor
PSK	Phase Shift Keying
QAM	Quadrature Amplitude Modulation
QOF	Quasi-Orthogonal Functions
QPSK	Quadrature Phase Shift Keying
R&D	Research and Development
RC	Radio Configuration
RF	Radio Frequency
R-CCCH	Reverse Common Control Channel
R-DCCH	Reverse Dedicated Control Channel
R-EACH	Reverse Enhanced Access Channel
R-FCH	Reverse Fundamental Channel
RMS	Root Mean Square
R-Pilot	Reverse Pilot
R-SCH	Reverse Supplemental Channel
SR	Spreading Rate
TIA	Telecommunications Industries Association
TTA	Korean Telecommunications Technology Association
TTC	Telecommunication Technology Committee
W-CDMA	Wideband-Code Division Multiple Access (3G system)

*For more information regarding these acronyms and other wireless industry terms, please consult our wireless dictionary at [www.agilent.com/find/wireless](http://www.agilent.com/find/wireless).*

## References

- [1] *Understanding CDMA Measurements for Base Stations and Their Components*, Application Note 1311, literature number 5968-0953E.
- [2] Ken Thompson, "Concepts of cdma2000," Wireless Symposium, 1999.
- [3] *HPSK Spreading for 3G*, Application Note 1335, literature number 5968-8438E.
- [4] *Designing and Testing W-CDMA Base Stations*, Application Note 1355, literature number 5980-1239E.
- [5] *Characterizing Digitally Modulated Signals with CCDF Curves*, Application Note, literature number 5968-6875E.
- [6] *Testing and Troubleshooting Digital RF Communications Transmitter Designs*, Application Note 1313, literature number 5968-3578E.
- [7] *Fundamentals of RF and Microwave Power Measurements*, Application Note 64-1B, literature number 5965-6630E.
- [8] R.N. Braithwaite, *Nonlinear Amplification of CDMA Waveforms: An Analysis of Power Amplifier Gain Errors and Spectral Regrowth*, Proceedings of the 48th IEEE Vehicular Technology Conference (1998), pp. 2160-2166.

## Related Literature

*89400 Series Vector Signal Analyzers*, literature number 5965-8554E.

*89600 Series Wide-Bandwidth Vector Signal Analyzers*, literature number 5980-0723E.

*E4406A Vector Signal Analyzer Brochure*, literature number 5968-7618E.

*E4440A PSA Series Performance Spectrum Analyzers*, literature number 5980-1283E.

*ESA-E Series Spectrum Analyzers*, literature number 5968-3278E.

*ESG Series RF Digital and Analog Signal Generators*, literature number 5968-4313E.

*ESG Signal Generator/Option 201 Real-Time IS-2000 Mobile Receiver Measurements*, Product Note, literature number 5968-9551E.

*EPM-P Series Single- and Dual-Channel Power Meters/E9320 Family of Peak and Average Power Sensors*, literature number 5980-1471E.

*EPM Series Power Meters*, literature number 5965-6380E.

*Designing and Testing cdma2000 Mobile Stations*, Application Note 1358, literature number 5980-1237E.

*Designing and Testing W-CDMA User Equipment*, Application Note 1356, literature number 5980-1238E.

*Generating Custom, Real-World Waveforms for 3G Wireless Applications*, Application Note 1298, literature number 5968-8388E.

*Wide-Range Sensor Gauges Power of Complex Signals* (written by Ron Hogan and originally printed in *Microwaves & RF*, September 1999), literature number 5968-8750E.

By internet, phone, or fax, get assistance with all your test & measurement needs

**Online assistance:**  
[www.agilent.com/find/assist](http://www.agilent.com/find/assist)

Phone or Fax  
**United States:**  
(tel) 1 800 452 4844

**Canada:**  
(tel) 1 877 894 4414  
(fax) (905) 282-6495

**China:**  
(tel) 800-810-0189  
(fax) 1-0800-650-0121

**Europe:**  
(tel) (31 20) 547 2323  
(fax) (31 20) 547 2390

**Japan:**  
(tel) (81) 426 56 7832  
(fax) (81) 426 56 7840

**Korea:**  
(tel) (82-2) 2004-5004  
(fax) (82-2) 2004-5115

**Latin America:**  
(tel) (305) 269 7500  
(fax) (305) 269 7599

**Taiwan:**  
(tel) 080-004-7866  
(fax) (886-2) 2545-6723

**Other Asia Pacific Countries:**  
(tel) (65) 375-8100  
(fax) (65) 836-0252  
Email: [tm\\_asia@agilent.com](mailto:tm_asia@agilent.com)

Product specifications and descriptions in this document subject to change without notice.

Copyright © 2001 Agilent Technologies  
Printed in U.S.A. December 17, 2001  
5980-1303E



**Agilent Technologies**