

STEAM TURBINES FOR LARGE POWER APPLICATIONS

J.K. Reinker and P.B. Mason
GE Power Systems
Schenectady, NY

ABSTRACT

Modern GE steam turbine designs for electrical power generation are the result of more than 90 years of engineering development. The product line of fossil-fueled, reheat steam turbines for both 50Hz and 60Hz applications extends from 125-1100 MW and is based on a design philosophy and common characteristic features that ensure high reliability, sustained high operating efficiency and ease of maintainance. This paper identifies GE's current product line for 50 and 60 Hz applications including High Power Density Designs™ incorporating advanced steam path design, installation and maintainence features which continue to make GE the preferred choice for power generation equipment.

INTRODUCTION

Modern GE steam turbines for electrical power generation are the result of more than 90 years of engineering development. The first GE production turbine was rated 500 kW and went into operation in 1901. Just two years later, a unit rated 10 times larger was placed in service at Commonwealth Edison's Fisk Street Station. Advances in the technology have continued since that time, and today a full product line is offered for both 50 Hz and 60 Hz applications, with ratings from 100 to over 1300 MW for fossil-fueled, reheat cycles, and from 600 to over 1500 MW for nuclear applications. Throughout the range of sizes and applications, GE steam turbines reflect a consistent philosophy of design and include common characteristic features that ensure high reliability, sustained high efficiency and ease of maintenance. This paper will describe the product line of GE steam turbines for electric power production utilizing steam from fossil-fuel fired boilers and nuclear reactors.

RATINGS AND CONFIGURATIONS

Fossil Units

Fossil utility steam turbines are that class of large, reheat units used almost exclusively for electric power generation. Because of their large size, usually greater than 200 MW, these units utilize

higher steam pressures (2400 psi/165 bar and higher), have several stages of regenerative heating and incorporate other design features to maximize performance, reliability and availability. GE's current product offering of utility steam turbines is based on the availability of new longer 50 and 60 Hz last-stage buckets and other recent advances made in steam turbine technology.

Last-Stage Buckets

Historically, increases in steam turbine ratings have been accompanied by longer last-stage buckets in order to maintain an economical unit size. Longer last-stage buckets can accommodate larger steam flows and loadings at relatively the same performance level by maintaining or reducing exhaust losses, without increasing the number of low pressure turbine flows. In the late 1960s, GE introduced its first continuously-coupled, last-stage bucket (LSB), the 60 Hz, 33.5-inch/851 mm LSB. This unique design utilized a cover, a supersonic tip section and other features resulting in the highest efficiency level of any LSB designed.

Its continuous coupling and loose construction resulted in exceptional damping and unsurpassed reliability. Because of the unequalled performance of the continuously-coupled design, GE underwent a redesign program to incorporate the features of continuous coupling in its existing families of 50 and 60 Hz LSBs.

With the successful implementation of the redesign program in the 1980s, development priority was given to the evolution of longer LSB designs. Although unit ratings have stabilized, longer buckets would result in more compact, cost-effective units. The longer LSBs include a 40-inch/1016 mm, 60 Hz titanium LSB and a 42-inch/1067 mm, 50 Hz LSB (Figure 1), which is a direct scale up of the modern 33.5-inch/851 mm, 60 Hz LSB. A 48-inch/1219 mm 50 Hz LSB scaled from the 40-inch/1016 mm design has also been introduced.

All fossil utility offerings, therefore, utilize the unique GE continuously-coupled, last-stage bucket designs.

High Power Density Designs™

The benefit of the increased annulus area associated with the longer last-stage buckets is demon-

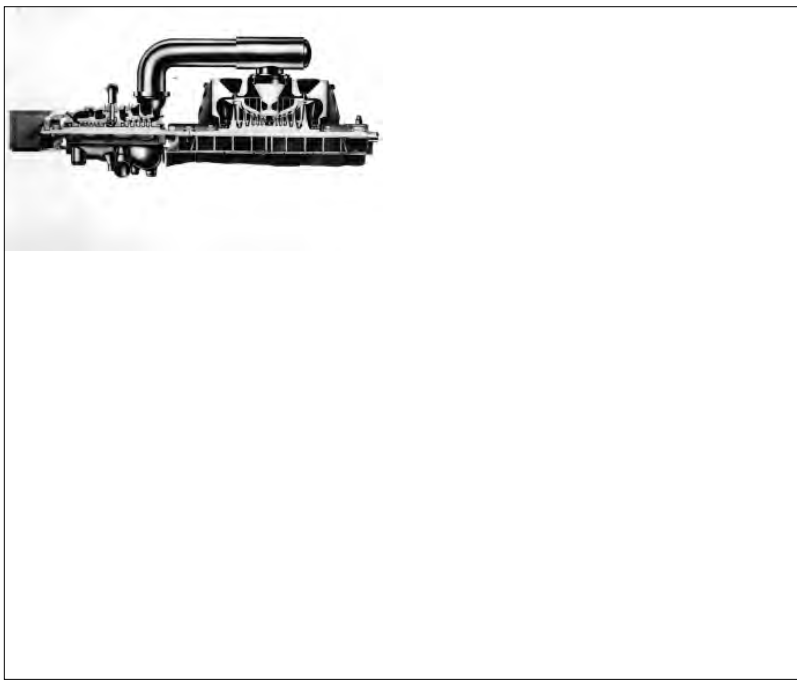

RDC27265-02-11

Figure 1. Double-flow, low-pressure rotor with 42-inch (1067 mm) last-stage buckets

strated in Figure 2. Each High Power Density design has the equivalent performance of the previous design, but with the benefits of a more compact steam turbine configuration. These benefits include a compact, cost-effective station design, faster, easier maintenance because of the fewer casings and components, and fewer spare parts to maintain. Reliability and availability of these sim-

pler designs is, therefore, expected to exceed that of previous designs.

Additionally, recent technological advances such as improved steam paths and rotor dynamics have evolved resulting in further improvements in unit configurations. These advances are discussed in more detail in “Advances in Steam Path Technology” and “High Power Density Steam Turbine Design Evolution.”

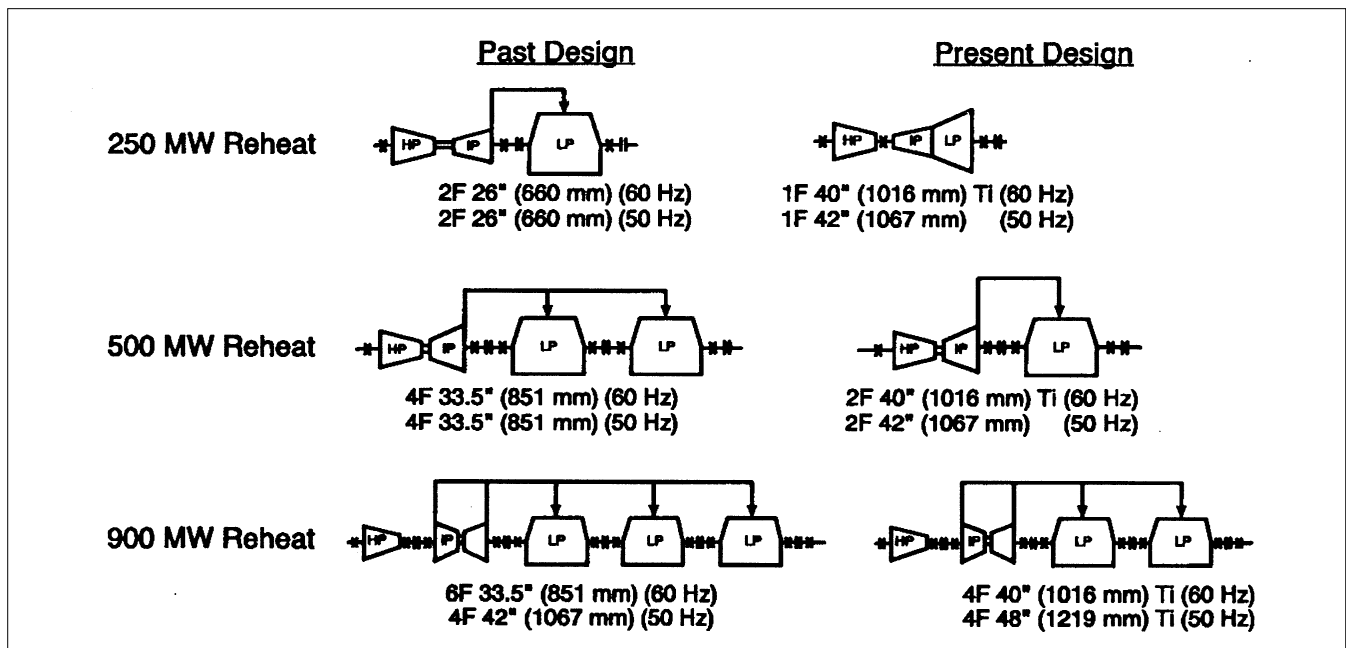

GT24510

Figure 2. High power density–last-stage bucket impact

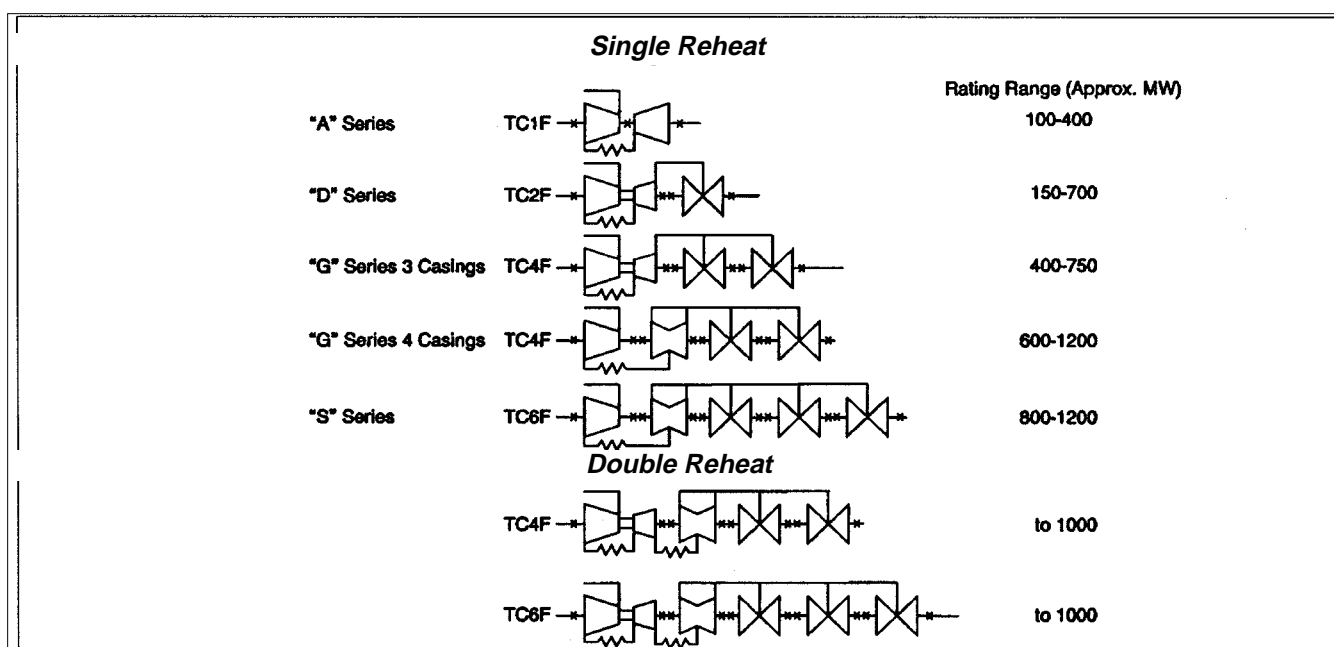

GT22243B

Figure 3. Fossil turbine arrangements

The complete family of High Power Density units for single reheat application with conventional steam conditions is shown in Figure 3 and representative cross sections are shown in Figures 4 -10. Each turbine type is available for a range of ratings with the selection of steam conditions and exhaust annulus area appropriate to the individual technical and economic conditions. The limit in rating shown for each configuration is approximate and will depend on such variables as steam conditions, exhaust pressure, number of admissions, number and location of extractions, and flow margin. All configurations are available with the capability to operate continuously at 5% overpressure if specified.

For the smallest utility ratings, the two-casing unit is available with a single-flow exhaust as illustrated in Figure 4. These designs utilize double-shell high pressure inlet construction, with the rugged nozzle plate design and direct actuated individual control valves with Admission Mode Selection (AMS) for both full and partial arc admission.

The next larger units are two-casing designs combining high and intermediate pressure sections in a single casing and double-flow low pressure turbine sections. This design uses double-shell, nozzle plate construction with shell-mounted control valves at the lower turbine ratings (Figure 5) and off-shell mounted control valves at the higher. For high temperature and pressure applications, the triple-shell nozzle box construction with a separately mounted stop/control valve chest is available (Figure 6).

For higher ratings, or for applications requiring additional annulus area, a unit with two double-flow low pressure sections is available. The three-casing design is shown in Figure 7, and the higher pressure design is shown in Figure 8. The higher output four-flow designs utilize separate high and intermediate sections as shown in Figure 9. Depending on the needed admission requirements, these units may have single or double-flow first-stage designs.

The highest rated single reheat units utilizing three double-flow low pressure turbines, Figure 10, use separate high and intermediate pressure sections and are available for units over 1200 MW. For these large ratings, cross compound units are also available if desired.

In addition to the designs shown, special designs to meet unusual conditions are also available. For example, sites with unusual heat rejection requirements may require a design suitable for exhaust pressures up to 15 inches HgA/381 mm HgA. Specially designed 50 and 60 Hz last-stage buckets are available for such applications.

Advanced Steam Conditions

GE continues to be the leader in the development of high performance large steam turbines. In the late 1960s, GE introduced into service the first of several highly efficient, double reheat units with supercritical steam pressures and advanced steam temperatures. Double reheat units utilize an opposed-flow, high pressure, first reheat section

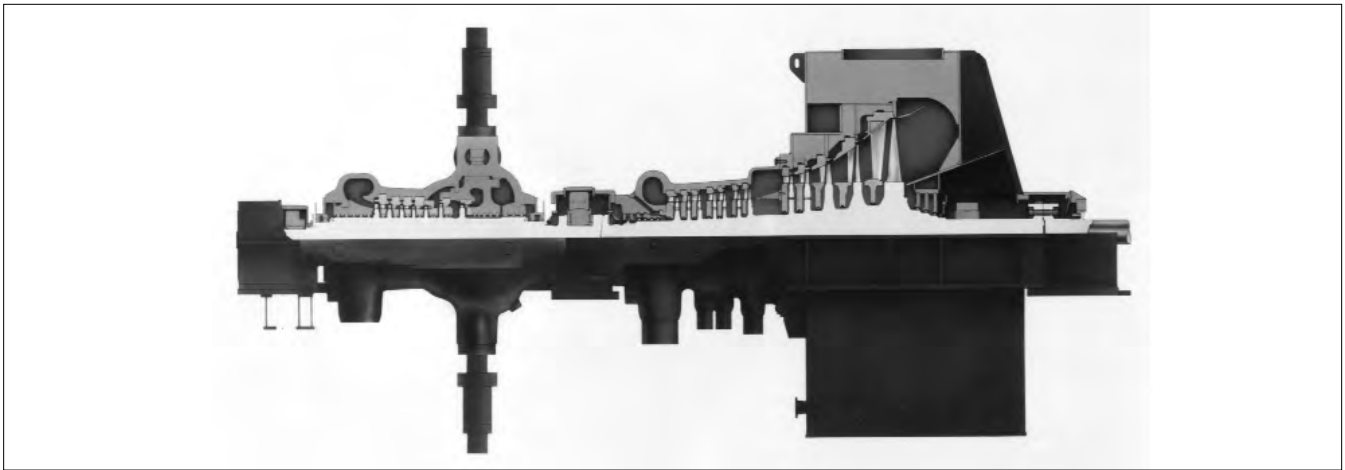

RDC27035

Figure 4. Two-casing, single-flow steam turbine

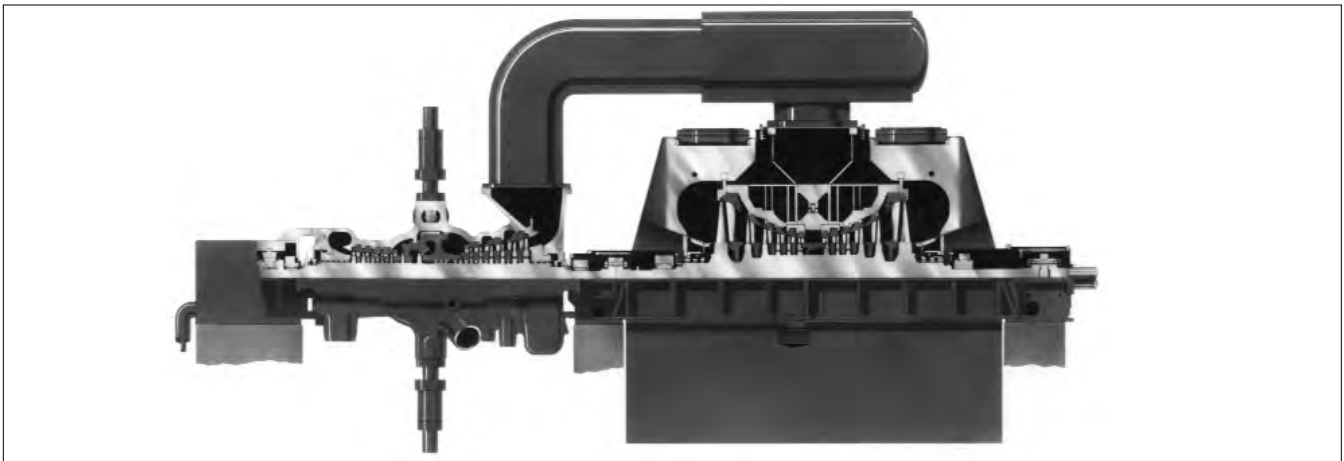

RDC27015-03

Figure 5. Two-casing, double-flow steam turbine with shell-mounted valves

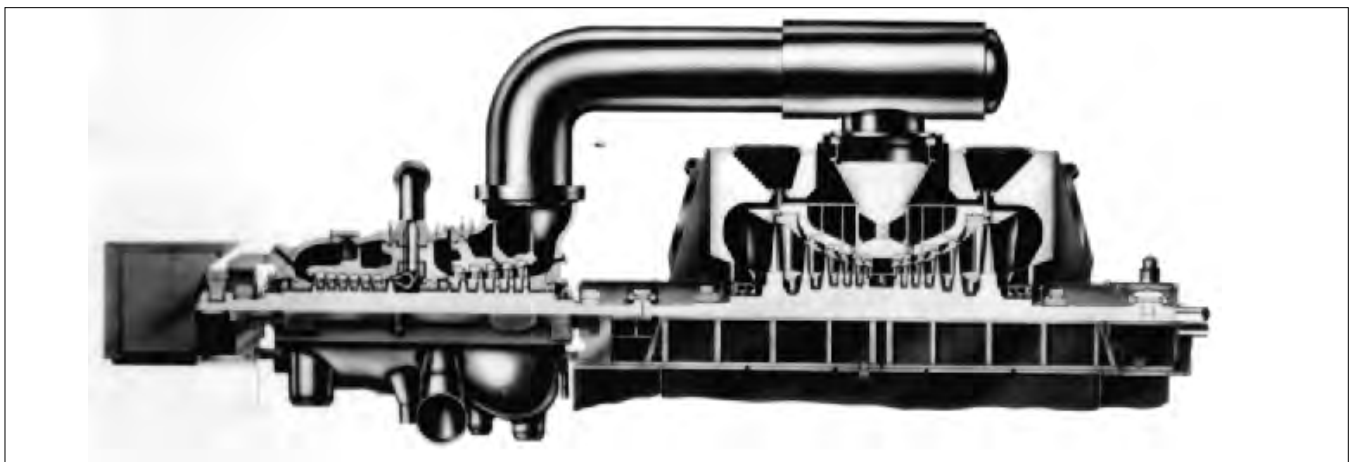

RDC270153

Figure 6. Two-casing, double-flow steam turbine with off-shell valves

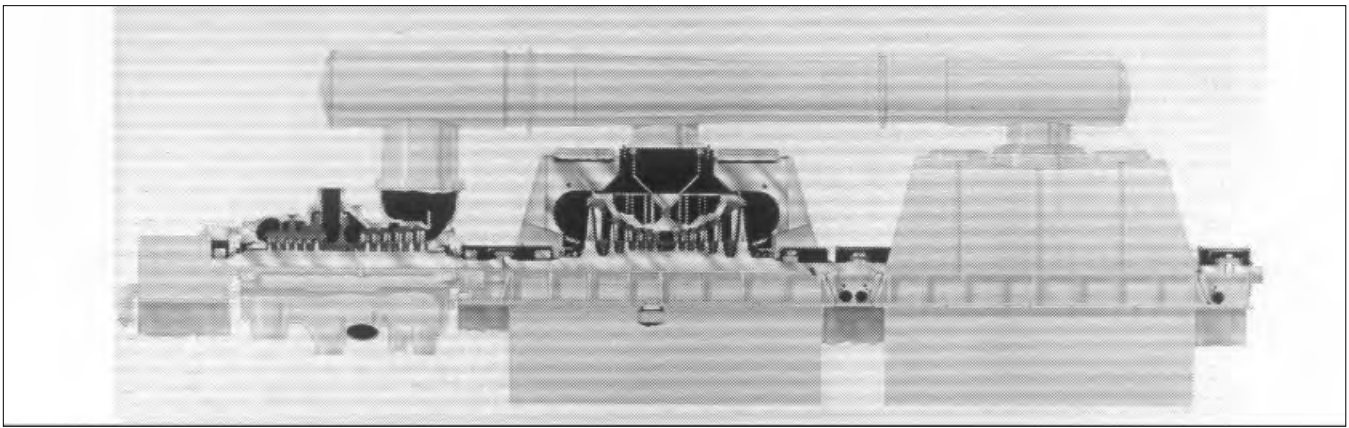

RDC27045

Figure 7. Three-casing, four-flow steam turbine

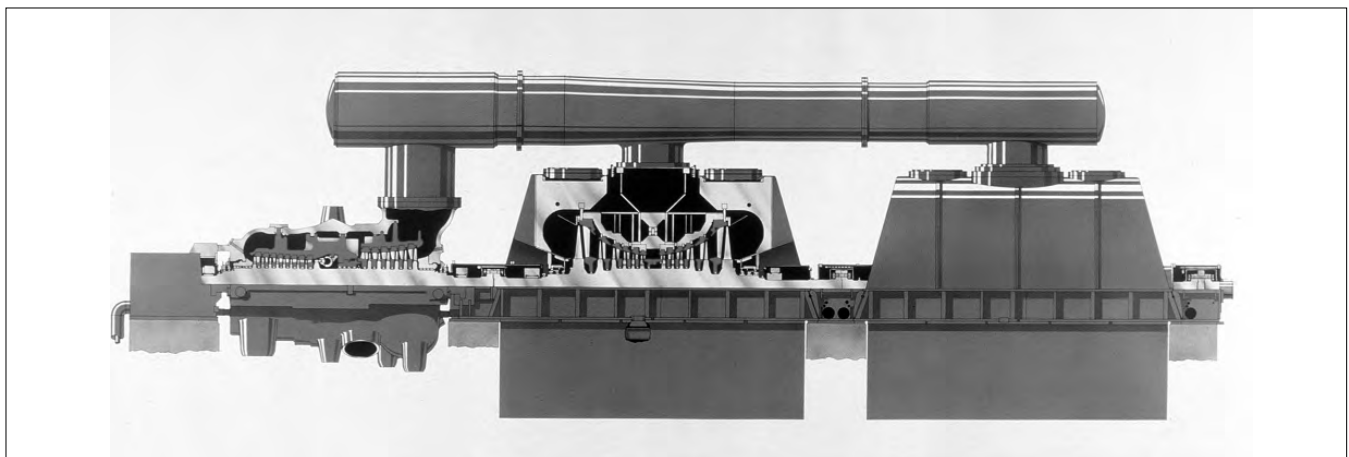

RDC27091

Figure 8. Three-casing, four-flow steam turbine

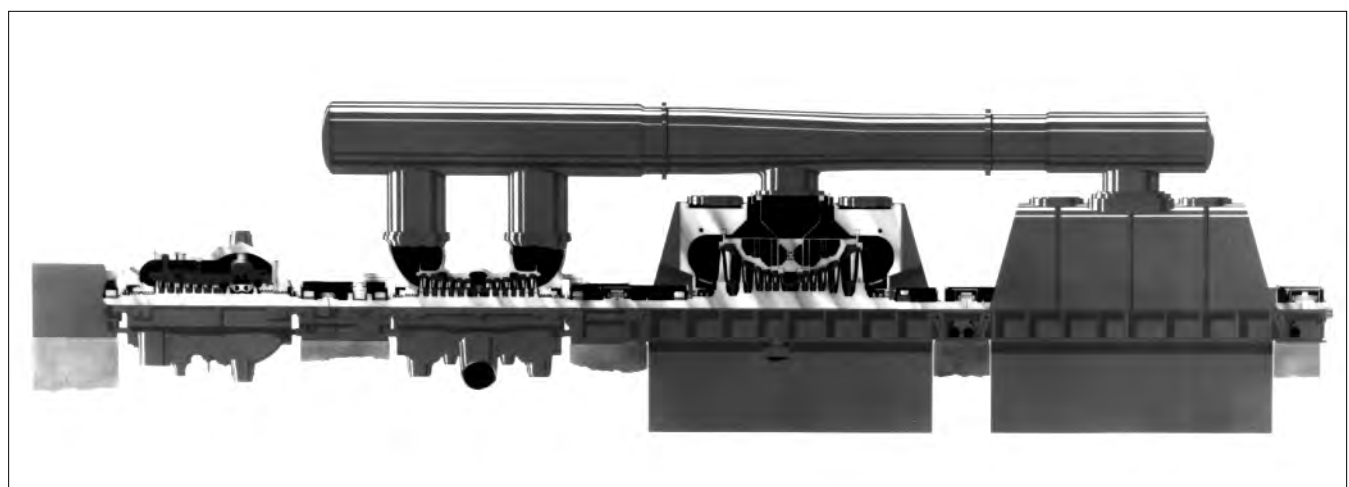

RDC27199

Figure 9. Four-casing, four-flow steam turbine

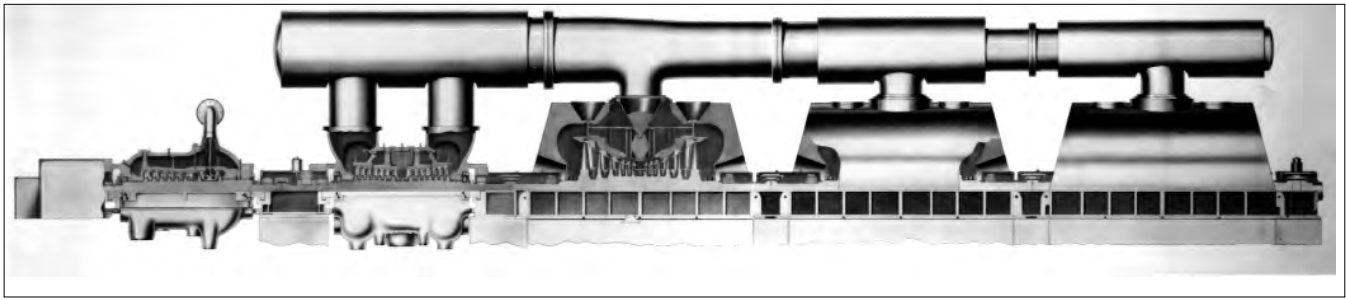

RDC24265-7

Figure 10. Five-casing, six-flow steam turbine

and are available at steam pressures up to 4500 psi/310 bar and ratings up to 900 MW in both four- (Figure 11) and six-flow low pressure configurations.

Highly efficient units with advanced steam conditions continue to be quoted on a selective basis. Reference 3 describes a 1000 MW class ultra supercritical unit for a Japanese customer with steam conditions in excess of 1100 F/593 C. Figure 12 is a 750 MW unit four-casing design recently offered with 48-inch/1219 mm titanium LSBs. This unit has ultracritical steam conditions of 3860 psi and 1071F/1112F (266 bar and 577C/600C) and includes special materials and cooling arrangements to accommodate the higher steam conditions. Performance is further enhanced by the use of state-of-the-art steam path technology including improved leakage controls, advanced air foils, advanced hood design, and other features to maximize efficiency.

Nuclear

While nuclear turbines are available for almost any capacity rating, the licensing requirements for nuclear reactors and the pressures of economy of scale have dictated applications almost exclusively at the larger ratings, utilizing four- and six-flow exhausts. However, by some projections future reactor designs may be smaller, on the order of 600

MW, and double-flow designs using 52-inch/1321 mm last-stage buckets will be suitable.

52-inch/1321 mm last-stage bucket designs are available for both 50 and 60 Hz applications. The first application of the 50 Hz, 52-inch/1321 mm last-stage bucket is a six-flow, 1356 MW unit powered by GE's Advanced Boiling Water Reactor (ABWR), which is currently in operation. The 60 Hz design is being used in the Electric Power Research Institute/Department of Energy funded FOAKE (First Of A Kind Engineering) ABWR plant.

Figure 13 shows the nuclear turbine configurations with moisture separator reheaters (MSRs) between the high-pressure and low-pressure sections. Figure 14 is a cross section for a typical six-flow design.

As with fossil turbines, each nuclear turbine is designed to meet the individual utility requirements in terms of rating, reactor steam conditions, and feedwater temperature and cycle parameters, such as steam reheating, reactor feedpump turbines, and feedwater heater and drain arrangements. Nuclear steam turbines are rated and designed for flow-passing capability in the same manner as fossil turbines. However, they are designed to be suitable for the part-load pressure characteristics of the particular reactor steam supply and are not usually designed for a throttle pressure 5% above rated pressure at valves-wide-open flow.

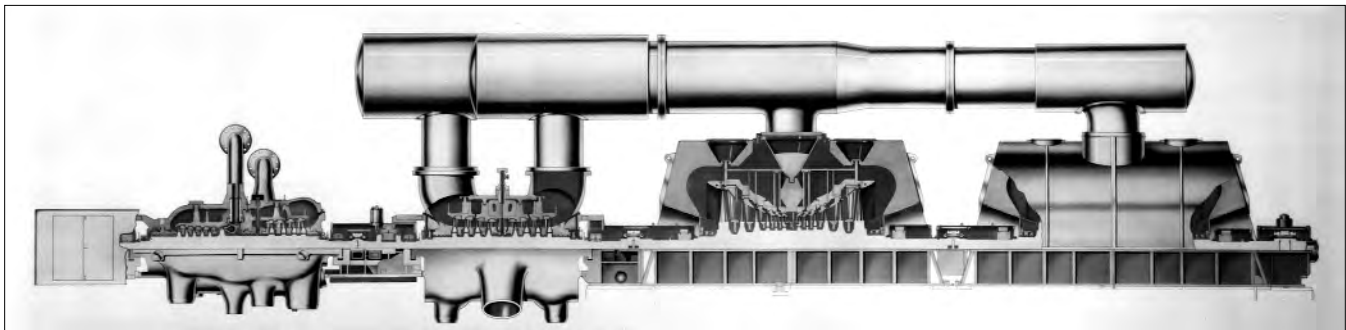

RDC24265-04

Figure 11. Four-casing, four-flow, double-reheat steam turbine

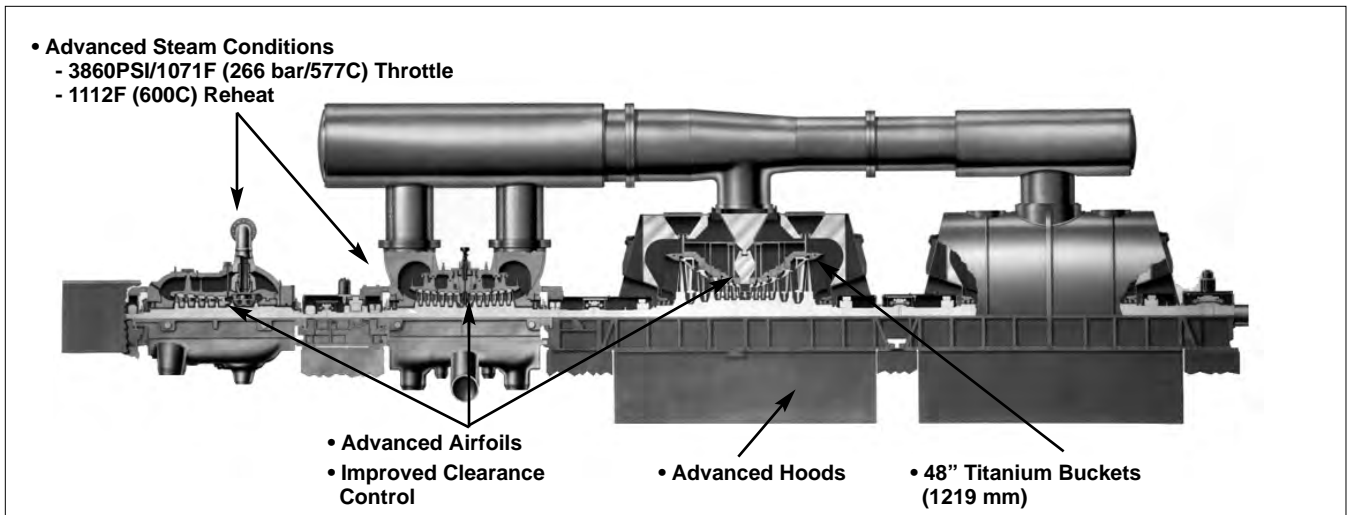

GT24018A

Figure 12. Ultrasupercritical steam turbine

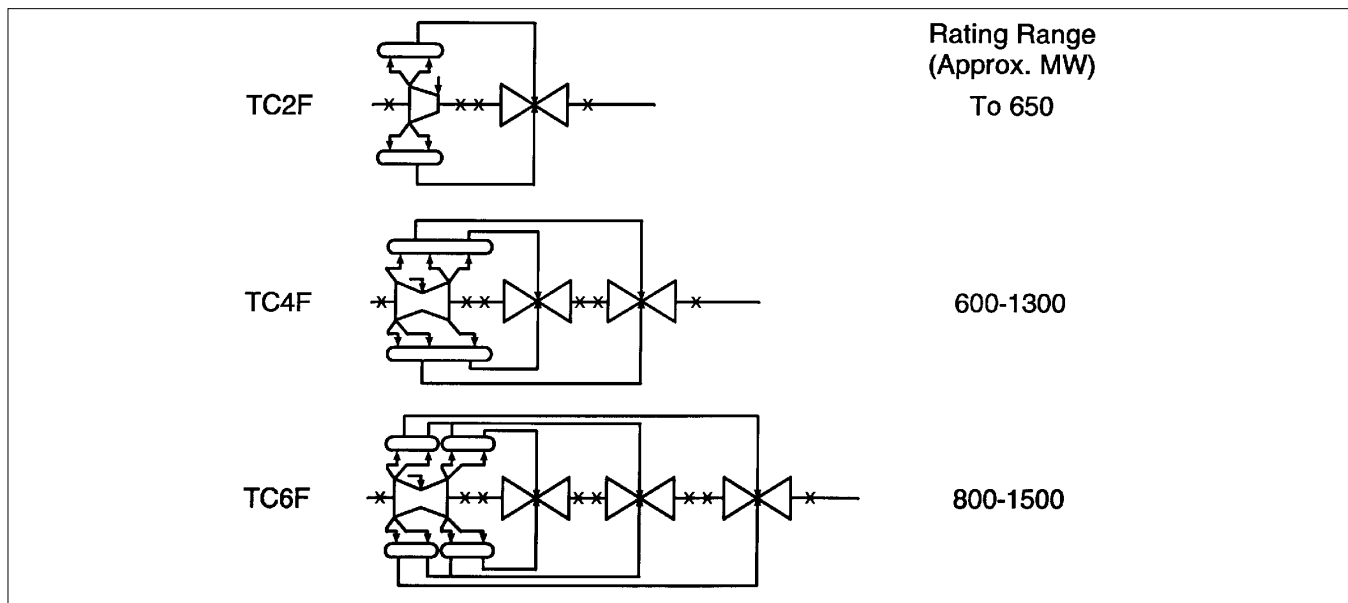

GT23242

Figure 13. Nuclear turbine arrangements

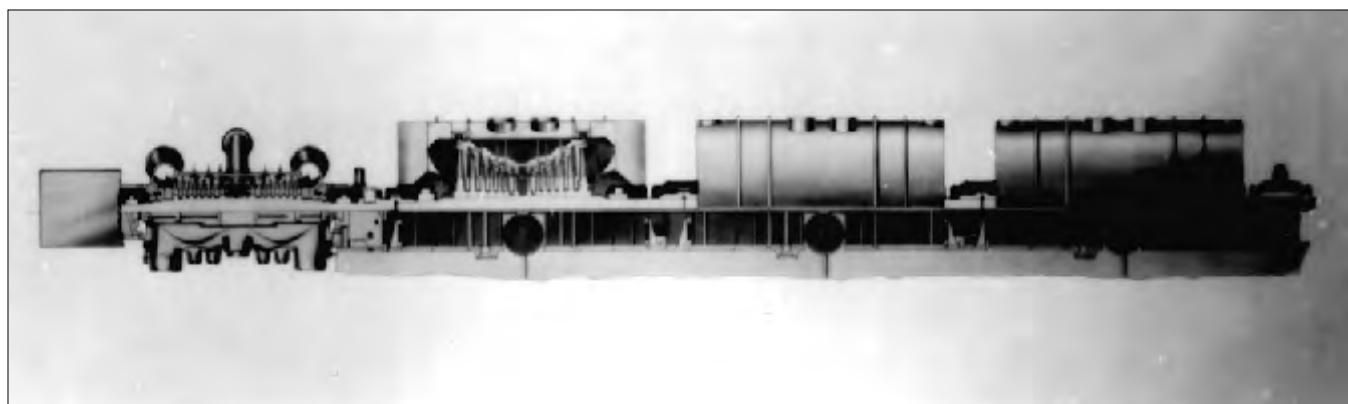

RDC24265-1

Figure 14. Six-flow nuclear steam turbine

MAJOR DESIGN FEATURES

GE steam turbines across the range of ratings and applications have a number of consistent characteristic features. As designs are developed, there are almost always conflicting considerations, and major design features result from many years of experience with many units in operation. The reason a particular feature is adopted over alternative design approaches is not always obvious.

Impulse Staging with Wheel-and-Diaphragm Construction

The single most important factor relating to design features is the use of impulse stage design, which in turn leads to a construction known as wheel-and-diaphragm. This is in contrast to the major alternative technology of reaction stage design with a drum-type rotor and related construction features. GE developed the impulse design technology after joining forces in 1896, with Charles G. Curtis, who held basic patents.

In a pure impulse stage, the entire stage pressure drop is converted into velocity in the fixed nozzles. There is no pressure drop across the moving buckets, which only impose a change in direction of the steam and absorb energy by momentum exchange. In a reaction turbine, some portion of the stage pressure drop, typically 50%, takes place across the moving blades, increasing the velocity of the steam and imparting energy to the blades by reaction, as well as momentum exchange. Peak efficiency is obtained in an impulse stage with more work per stage than in a reaction design (Figure 15), assuming the same diameter. It can be deduced from Figure 15, that a reaction turbine design will require either twice as many stages or 40% greater stage diameters, or some combination thereof, for peak efficiency. GE turbines employ significantly less reaction and have approximately 40% fewer stages in the HP and IP sections than is typical of reaction designs. The contrast is less in the low-pressure section where the long bucket length results in a significant increase in velocity of the bucket from the root to the tip. An efficient design requires an increase in the degree of reaction from the root to the tip, and the low-pressure stage designs of impulse and reaction turbines tend to be similar.

In the GE stage design, the buckets are mounted on the periphery of wheels and the nozzle partitions are supported in diaphragms, as shown in Figure 16. Because of the relatively large pressure drop that exists across the moving blades in the reaction design, a very high thrust force would exist on the rotor if the blades were mounted on wheels with

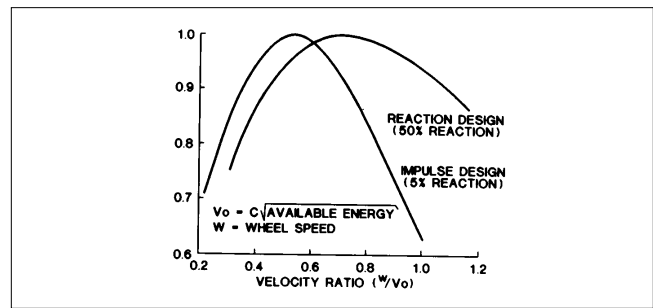

T20472A

Figure 15. Ideal stage efficiency as a function of velocity ratio for impulse and reaction stage designs

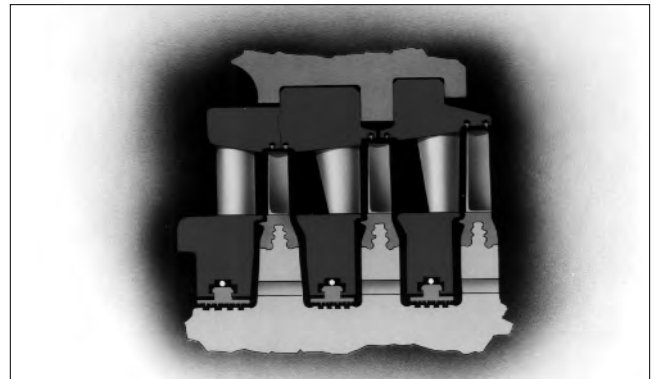

RDC27217

Figure 16. Typical impulse stages, wheel-and-diaphragm construction

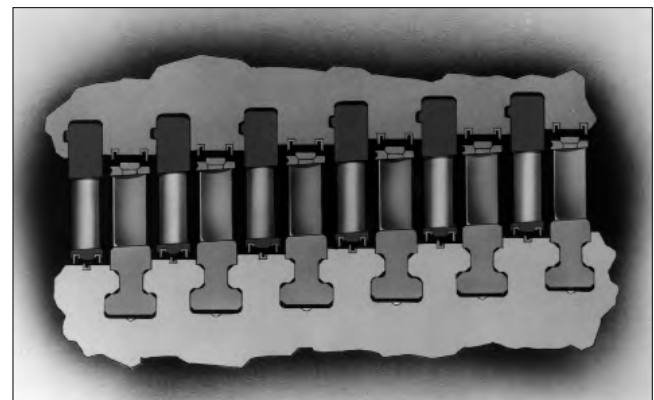

RDC27218

Figure 17. Typical reaction stages, drum rotor construction

faces exposed to the pressure differential. A drum-type rotor, as shown in Figure 17, is used in reaction-type turbines to avoid excessive thrust.

The significant differences that are associated with these two basic constructions can be separated into those affecting efficiency and those affecting mechanical integrity.

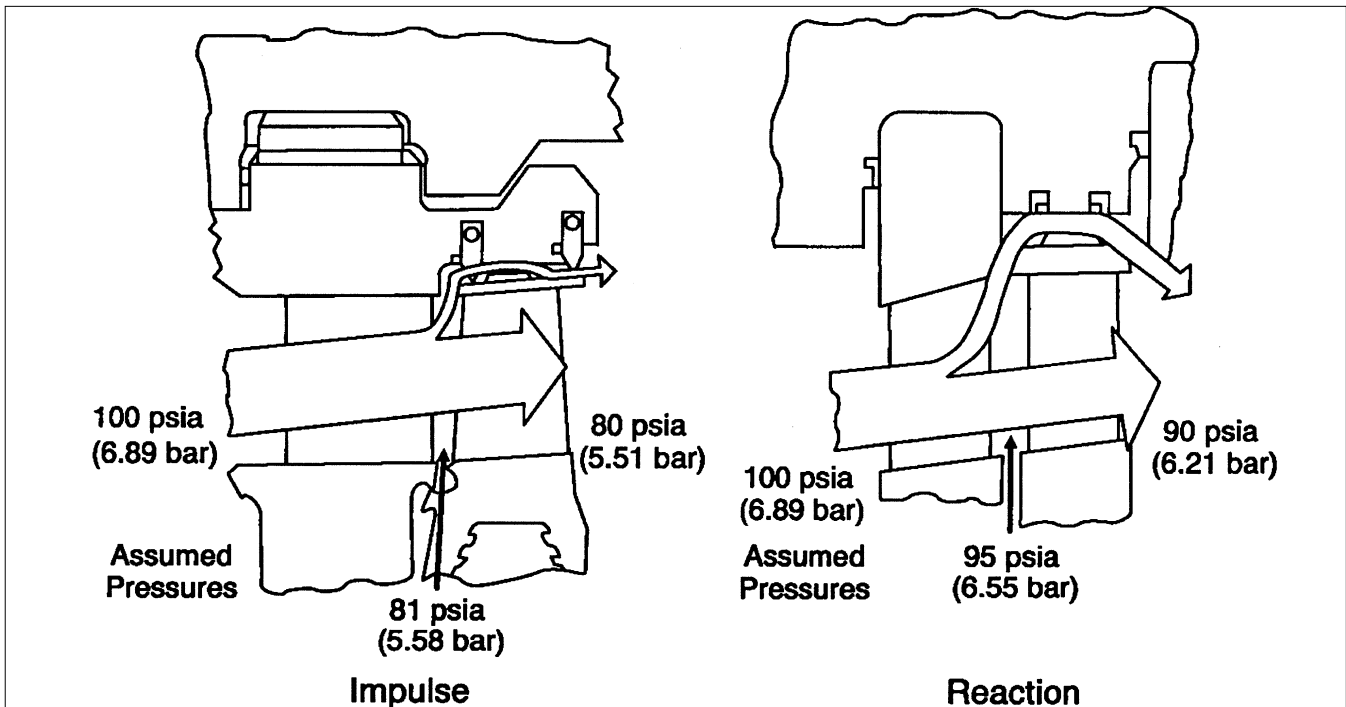

Figure 18. Tip leakage for impulse and reaction stages

GT20475B

Efficiency

Minimizing stage leakage flow is important to stage efficiency. With less pressure drop across the buckets, the loss due to leakage at the bucket tip is obviously much less for an impulse design than for a reaction design, as shown schematically in Figure 18.

Greater pressure drop exists across the stationary nozzles in an impulse design than in a reaction design. However, the leakage diameter is typically 25% less and, therefore, the cross-sectional area for leakage is less. Also, with fewer stages there is sufficient space between wheels to mount spring-backed packings with generous provision for radial move-

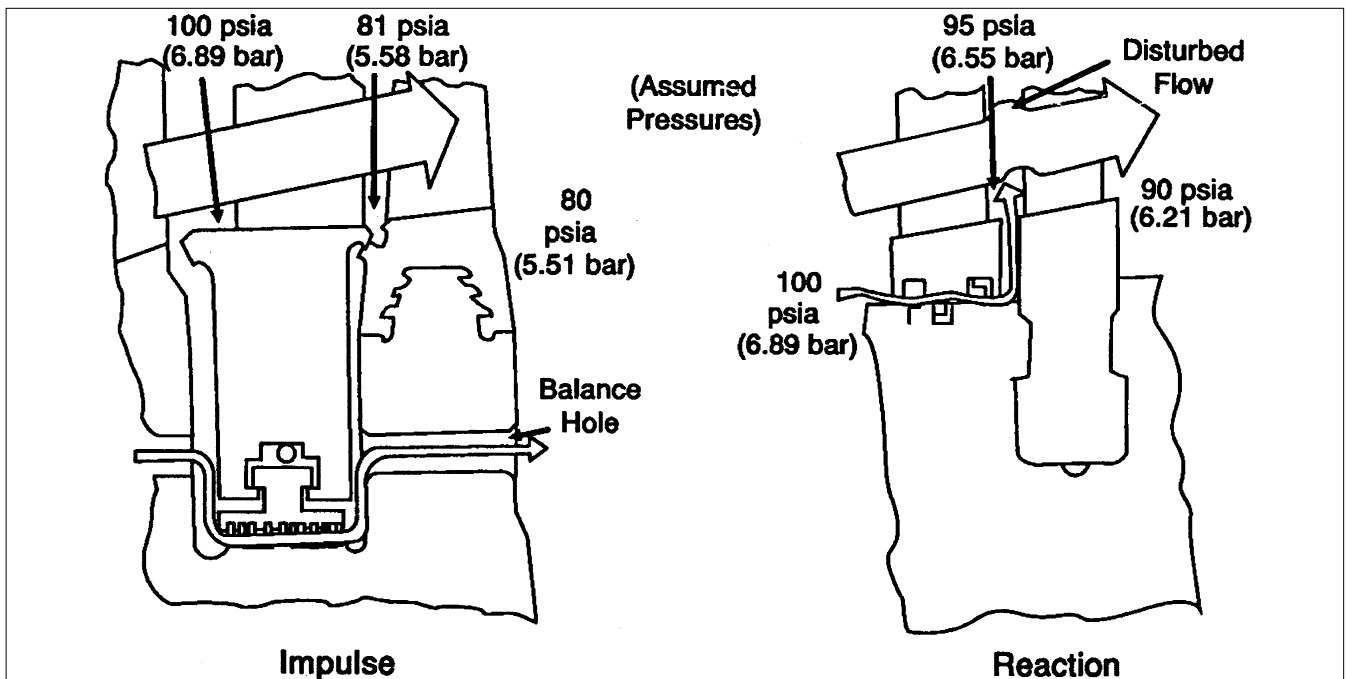

Figure 19. Root leakage for impulse and reaction stages

GT20476A

ment and a large number of labyrinth packing teeth. In total, the leakage at the shaft packing of an impulse stage is less than that of a reaction stage. The efficiency advantage is even greater than that suggested by the difference in leakage, however, because, as shown in Figure 19, the leakage flow in the impulse stage passes through a balance hole in the wheel and does not reenter the steam path. Because the construction of a reaction stage precludes the use of balance holes, the leakage flow must reenter the steam path between the fixed and moving blades causing a disturbance of the main steam flow leading to a significant, additional loss.

In high-pressure turbine stages typical of modern designs, tip leakages are two to four times greater and shaft packing flows are 1.2 to 2.4 times greater for a reaction design than for an impulse design for turbines of equal rating. The total efficiency loss is even greater due to the reentry effect of the shaft packing flow inherent with the drum rotor. The effect of leakage losses on stage performance, of course, becomes smaller as the volume flow of the stages increases for both reaction and impulse designs. On a relative basis, however, the leakage losses on a reaction stage will always be greater than those on an impulse stage designed for comparable application. This is also significant from the standpoint of sustained efficiency because the impulse design is less sensitive to the effects of increased packing clearances that might occur in operation.

With more energy per stage, steam velocities in an impulse stage are higher than in a reaction stage. These higher velocities have the potential of resulting in profile losses that could offset the effects of reduced leakage loss if poor nozzle and bucket profiles were used. This was a legitimate concern in the early days of steam turbine development with only very simple bucket profiles used. Profile losses, however, are very amenable to reduction with increased sophistication of nozzle and bucket profiles. With current computer analysis methods and aerodynamic testing techniques (Figure 20), significant gains continue to be made in reducing profile and other secondary losses.

With an impulse design, the pressure drop across the diaphragm of the first stage of the reheat and low-pressure sections is high relative to the velocity head of the steam in the inlet pipe, ensuring a uniform flow distribution through the stage. With the lower pressure drop of a reaction stage, poor flow distribution in the first stage of a section can cause performance losses, and complex means such as inlet scrolls are sometimes used to improve flow distribution. Such designs have very little ben-

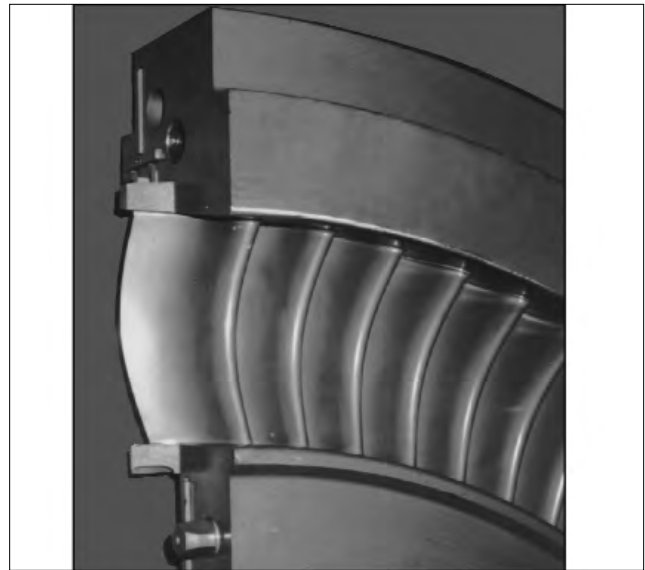

GT25603

Figure 20. Advanced three-dimensional aero stages

efit with the GE impulse design.

Mechanical

Impulse stage design with wheel-and-diaphragm construction lends itself to a rugged, reliable design because the pressure drop occurs across stationary, rather than moving, parts and because the need for fewer stages permits space for sturdy diaphragm design.

Because of the low stage thrust, a balance piston is not required as it is with reaction turbines. Thrust bearings are used with conservative loading without resorting to large sizes.

Thermal stresses in high-temperature rotors limit the rate at which a turbine-generator can change load. These stresses, which are greatest at the rotor surface, depend heavily upon the diameter of the rotor body and the corresponding stress concentration factors. The wheel-and-diaphragm design results in significantly smaller rotor body diameter and permits ample axial spacing between stages for generous fillet radii at the intersection of the packing diameter and the side of the wheels, resulting in low stress concentration factors at the point of maximum thermal stress. In contrast, the stress concentration factors on drum rotors are relatively high because of the intricate geometry required for blade attachment. The wheel-and-diaphragm construction, therefore, leads to significantly lower rotor thermal stresses and greater capability for load cycling operation.

Furthermore, the wheel-and-diaphragm design separates the region of maximum rotor thermal

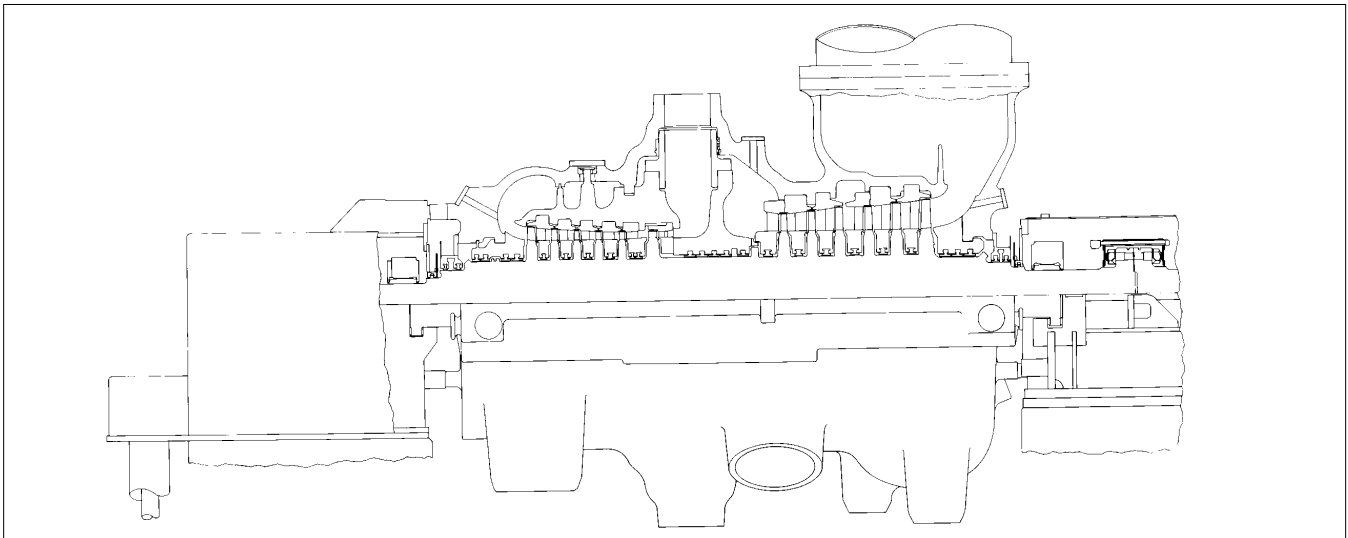

GT23809

Fig. 21. Arrangement of opposed-flow, high-pressure and intermediate-pressure sections

stress from the bucket dovetail region. The dovetail region of the rotor is most likely to be affected by creep resulting from the combination of high temperature, intricate geometry, and tensile stress due to the centrifugal load of the buckets. In the drum construction these areas are at the same location, as can be seen from Figure 19, and any creep damage will be additive to low cycle fatigue damage caused by temperature cycling.

One additional advantage of wheel-and-diaphragm construction arises because high pressure and reheat inner shells with heavy joint flanges tend to undergo distortion due to uneven thermal expansion. Interstage and tip seals are generally supported directly from the inner shells in reaction turbines, and distortion of the shell results in movement of the seals, exacerbating the problem of limiting leakage flow. It is GE's practice to support both of these seals from the diaphragm which is unaffected by any distortion of the shell. This arrangement can be seen in Figure 16. Various constructions have been developed with reaction turbines to eliminate or minimize the distorting effect of the joint flange on seal clearances. In one approach, the two halves of the inner shell are held together by a series of rings installed with a shrink fit, creating inward radial forces. This can eliminate the horizontal joint flange, but makes assembly and disassembly difficult. The problem that this design addresses does not exist with GE diaphragm construction.

It is significant to note that although reaction stage design virtually dictates the use of a drum rotor, with an impulse stage design either wheel-and-diaphragm or drum construction could be used. Wheel-and-diaphragm construction is the

choice because of its many mechanical and efficiency-related advantages.

Opposed-Flow, High-Pressure/Intermediate-Pressure Design

The single-span, opposed-flow HP/IP design, shown in Figure 21, was introduced by GE in 1950, in a turbine rated 100 MW. Today there are over 500 turbines with this feature in operation. It is a highly-developed design with a maximum rating that has increased over the years. The present limit is approximately 650 MW for partial arc units, and 750 MW for full arc machines. This arrangement results in a significantly more compact turbine and station arrangement than that of a unit with the high-pressure and reheat sections in separate bearing spans. There is also one less turbine section to be maintained.

High-pressure steam enters the center of the section and flows in one direction (to the left in Figure 21), while steam reheated to similar temperature also enters near the center and flows in the opposite direction. This arrangement confines the highest temperature steam to a single central location and results in an even temperature gradient from the center toward the ends, with the coolest steam adjacent to the end packings and bearings.

The opposed-flow design is more compact than a design with separate high-pressure and reheat sections. Tests have shown that this leads to a lower rate of temperature decay after overnight and weekend shutdowns permitting more rapid restarting.

Although a number of factors affecting performance, including stage packing diameters, shaft-

end packing leakage, and volume flow effects, are different in the opposed-flow design and a design with separate HP and IP sections, the net difference in performance is essentially zero at all ratings.

Reliability statistics on the entire fleet of GE turbines operating in the United States indicate a small but consistent advantage for the opposed-flow design over a design with separate sections at the same rating.

The bearing span for the opposed-flow rotor is greater than the bearing span for either rotor of a unit with separate high-pressure and reheat sections. Also, the shaft diameter tends to be somewhat larger as a result of designing for similar dynamic characteristics. This could be a disadvantage at the very largest ratings if the boiler and other plant equipment have a greater capability for rapid starting and loading, and if the unit will cycle frequently. When carefully studied, however, this is seldom found to be the case. In most cases the GE opposed-flow design with wheel-and-diaphragm construction will have starting and loading capability comparable to a drum-type design with separate high-pressure and reheat sections. Nevertheless, an arrangement with separate HP and IP sections can be provided in the larger ratings when it is believed that the disadvantages are justified by a need for better starting and loading characteristics.

Inlet Configurations

With the exception of the very largest units, and other special cases which do not warrant it, GE utility units have individually actuated control valves with Admission Mode Selection (AMS), which allows the unit to operate with the benefits of either full or partial arc operation.

With partial-arc admission, the first-stage nozzles are divided into separate nozzle arcs with each arc independently supplied with steam by its own control valve. For units operating with constant initial pressure, load is reduced by closing these valves in sequence. For smaller units, all four valves would operate in sequence providing four consecutive admissions. For the largest units in a given configuration, three valves would initially operate together and one separately to provide two admissions. Intermediate-size units would have two valves closing together with the remaining two closing in sequence to give a three-admission unit. The impact on part load performance for these admission modes is illustrated in Figure 22.

With a single-admission (or full arc) machine, load is controlled by throttling on all of the admission valves equally, and all control valves connect

into a common chamber ahead of the first-stage nozzles. As load is decreased on the single-admission unit, an increasing amount of throttling takes place in the control valves. In a partial-admission unit on the other hand, less throttling loss occurs at reduced load because the valves are closed sequentially, and only a portion of the steam admitted at any given load undergoes throttling, while the remaining flow passes through fully-open valves.

With AMS, the unit can be used for starting and loading in full arc admission, reducing thermal stresses, and converting to partial arc admission for improved steady-state performance.

Variable-pressure operation, using boiler pressure to vary load at a fixed valve position, is now common, and the question is sometimes raised as to whether the partial-arc admission feature is economical.

If load is reduced by varying pressure with valves wide-open, load increase can only be achieved by increasing boiler pressure, which is a relatively slow process, and the unit cannot participate in system frequency control. These shortcomings can be overcome with a hybrid method (Figure 22) of operation in which load is reduced approximately 15% at constant pressure, providing some "throttle reserve" before beginning to reduce pressure. With partial-arc admission, it is attractive to fully close one valve and then vary pressure. If a greater capability for rapid load increase is desired, two valves can be closed. In either case, partial-arc admission yields a better heat rate than full throttling, even with variable pressure operation.

Solid Particle Erosion Resistance

Carryover of iron oxide particles from boiler superheater and reheater tubes can cause severe erosion to turbine nozzles and buckets. Solid particle erosion (SPE) has a major economic effect in

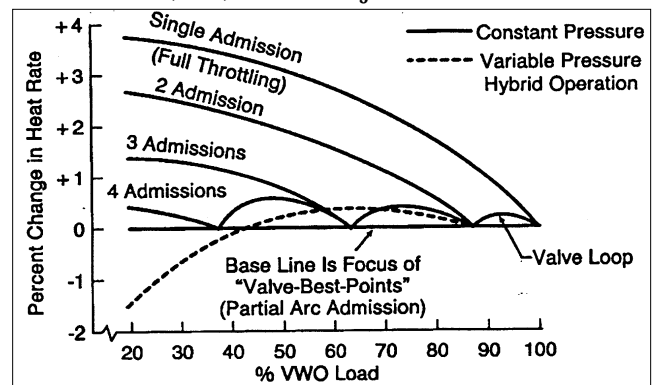

GT24516

Figure 22. Effect of admission modes and throttle pressure programs on heat rate

loss of sustained efficiency, and in causing need for longer and more frequent maintenance outages. Extensive efforts to understand the erosive mechanisms in the turbine steam path and develop resistant coatings have led to substantial improvements in the erosion resistance of GE turbines.

Analysis of particle trajectories in steam as a function of density and velocity has led to changes in geometry of nozzle partitions and relative spacing between nozzles and buckets in the first high-pressure and reheat stages, that result in dramatic decreases in the rate of erosion. These features, along with either plasma spray or diffusion-applied hard coatings in the same regions, are available on reheat turbines operating with fossil-fuel fired boilers with steam temperature of 1000F/538C or greater.

Centerline Support

Turbine components undergo considerable thermal expansion as they undergo changes in temperature. The various stationary components surrounding the rotor in GE turbines are supported at, or very close to, the centerline, and are free to expand radially to maintain concentricity. As shown in Figure 23, all diaphragms are positioned

by means of radial keys inside inner shells and, in a similar manner, inner shells are positioned inside outer shells, or hoods, by means of radial surfaces at the horizontal joint and at the vertical centerline. Finally, the outer shells are supported by the rotor bearing standards at their true horizontal centerlines.

Number of Bearings

GE has considerable experience both with turbine designs employing two bearings per rotor span and with designs that employ fewer bearings. There are advantages and disadvantages to both approaches, but overall the use of two bearings per rotor on large turbines is considered to have sufficient advantage to justify the additional cost and, sometimes, added length. The benefits are less clear, however, on smaller units and three turbine bearings in two-casing machines with single-flow exhausts or small double-flow exhausts are currently used.

The use of two bearings per rotor gives the designer flexibility to accurately establish rotor critical speeds by selection of bearing span. It results in shorter bearing span and, therefore, smaller rotor body diameter, which is beneficial to efficiency and

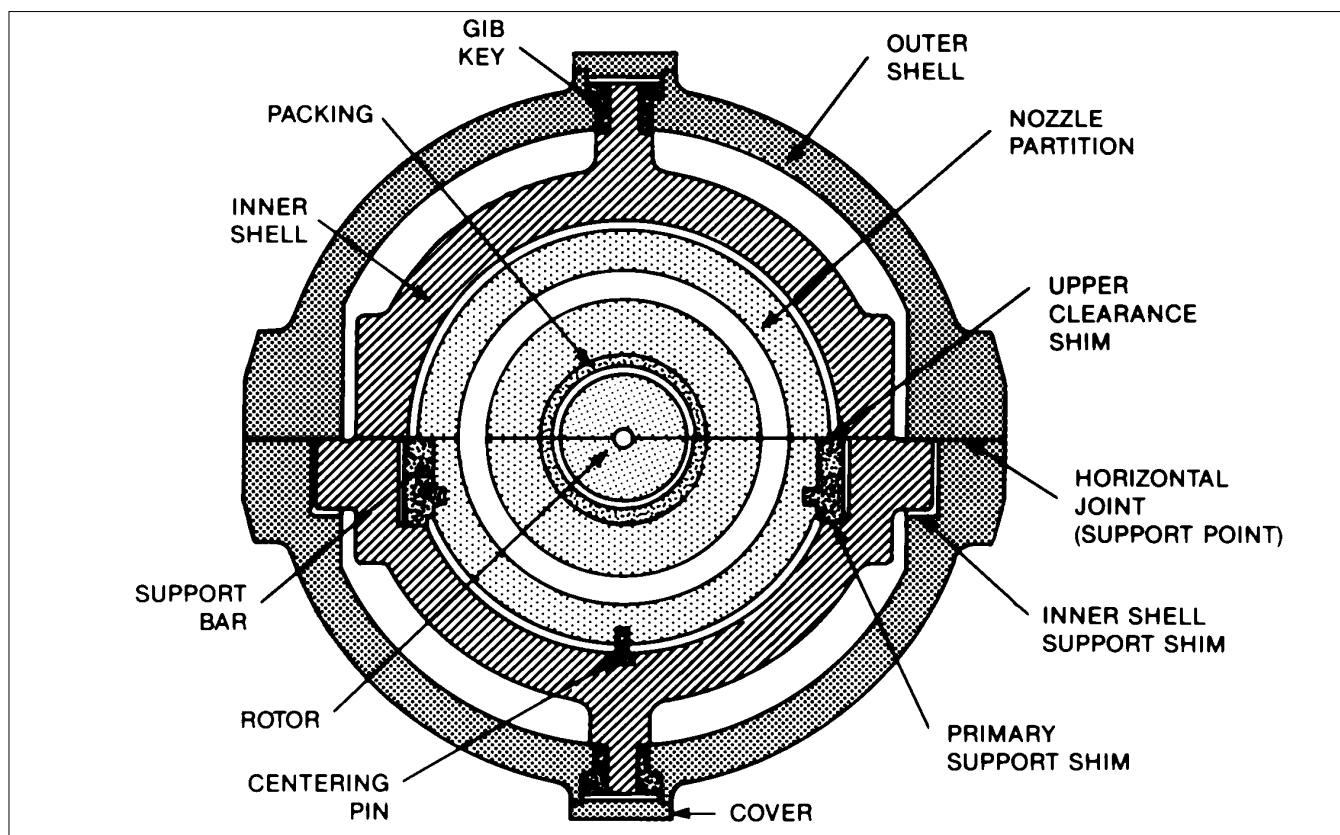

GT20468

Figure 23. Method of location of stationary components

starting and loading capability. The shorter, stiffer rotors between bearings and the added damping of the additional bearings reduce susceptibility to rotor instability.

With two bearings per rotor, each rotor can be precision, high-speed balanced on its own journals in the factory. The result is a finely-balanced turbine rotor that can be assembled to the other rotors in the field, and in nearly all cases started without additional balancing. If additional balancing is necessary at start-up or following a turbine outage, it can easily be accomplished with a minimum of balance shots and downtime because of the relatively small dynamic interaction between adjacent rotors. The imbalance can be located and corrected with a small impact on availability of the unit.

The shared-bearing rotor design results in a rotor system that is more sensitive to imbalance and more difficult to field balance. Turbines with one bearing per span have rotors that are factory balanced using a stub shaft or temporary journal. This procedure creates a difference between the rotor operating conditions during factory balance and the actual conditions, when the rotors are fully assembled in the turbine-generator. The result is that rotors may require some rebalancing after assembly in the field, and since there is more dynamic interaction between adjacent rotors, balancing is more difficult to accomplish.

General maintenance and bearing inspection are easier with two bearings per rotor. An auxiliary bearing is not required for support when a coupling is broken. As a result, coupling alignment can be more accurately established, further contributing to smooth operating characteristics.

The major benefit of using fewer bearings, other than cost, is that some reduction in overall length of the unit can be achieved. Designing for two bearings per rotor requires some additional length to achieve adequate rotor flexibility between adjacent bearings and thereby, tolerance for misalignment.

Crossover

GE's fossil turbines use a single crossover to transport steam from the intermediate-pressure turbine exhaust to the low-pressure turbine inlets. Pressure-balanced expansion joints, as shown in Figure 24, are provided to permit differential thermal expansion between the crossover and the stationary parts it connects without imposing large axial forces due to steam pressure. The stainless steel bellows have high reliability in this application, since there is no load imposed in torsion or bending.

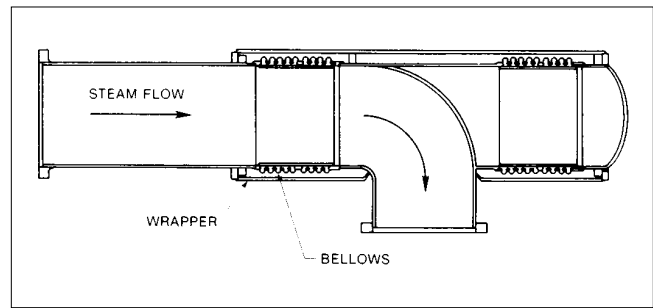

GT20479

Figure 24. Crossover expansion joint

Compared to use of a cross-around pipe on each side of the turbine, this design makes for a less cluttered turbine arrangement with unobstructed access at the floor level. There is also a reliability advantage in that only half as many bellows are required.

In most cases there is also an advantage in reduced bearing span of the IP section and overall length of the machine by making the IP exhaust connection in the upper half and the reheat inlet and extraction connections in the lower half (Figure 21).

Because of the very large volume flow between the high-pressure exhaust and the low-pressure inlets with nuclear turbines, and the presence of moisture separator reheaters between the same points, from four to eight cross-around pipes are used. The routing is generally three-dimensional, therefore inherently flexible, and the temperatures involved are low, so that expansion bellows are not required.

Accessories

GE continually refines the accessories of the turbine to ensure the highest levels of reliability and lowest initial investment for the owner.

In the area of controls, the modern triply-redundant Mark V control system provides unit control and interface to the plant DCS. The reliability of modern control systems allows for the use of dual path electronic overspeed protection versus the traditional mechanical overspeed protection with backup electrical system. The speed and the overspeed are independently monitored by three separate sensors for each signal.

The lube oil system has been continually refined to provide higher levels of reliability. Recent improvements include the optional full-flow filters and conversion from a shaft-driven pump to a modern all-motor pumping system.

The remaining accessories such as hydraulic power unit and steam seal equipment are highly packaged to allow for ease of installation and main-

tenance. Each of these packaged systems allows for tailored selection of optional features.

Maintainability Features

The extent to which a turbine can be maintained without disassembly and the ease with which it can be disassembled and reassembled for inspection and maintenance directly impact availability and are important design considerations.

Disassembly of GE turbines is facilitated by a generally uncluttered arrangement, the use of two bearings per span, the use of opposed-flow HP/IP arrangements, to minimize the number of casings, and a minimum number of piping connections to the upper half shell. Any special tools or lifting devices required are provided. Optional features that can be provided include special hydraulically-extended coupling bolts and horizontal joint studs for outer shells and low pressure inner casings. In addition, a small jib crane installation for lifting bearing parts without removing the crossover is available, as shown in Figure 25.

Features that reduce the frequency with which major disassembly is required are, if anything, even more important. These include the SPE-resistant features that have been described, provisions for field balancing in all rotors, full-flow lube oil filters, positive-pressure, variable-clearance packings that provide increased clearance during start-up and normal close clearances at load, and access ports for steam path inspection by borescope coupled with long term maintenance packages, 10 year sectionalized inspection intervals are available.

Assembled Shipment

The practice for larger steam turbine configurations with two or more casings has been to field erect the unit. With installation time varying with

the number of casings, number of shifts, experience of the installer, etc., the total costs associated with the installation can be significant, and means of reducing installation costs have, therefore, been implemented on a continuing basis. Main steam valves, lube oil tanks, and other skid items have been packaged to minimize their installation costs and cycles. Innovations such as full flow lube oil filters and hydro-flushing, laser alignment techniques, and electronic measurement devices have also reduced the critical path installation cycle time.

Significant savings in both installation time and costs can now be realized by shipping the high pressure and intermediate sections of these larger units factory-assembled. High Power Density™ turbines are designed to be shipped assembled and can be, site transportation facilities permitting. Installing assembled high and intermediate pressure casings can typically eliminate 25-35 critical path installation days in the erection cycle, while reducing construction costs by 15% to 25%. In addition, storage and inventory control requirements are greatly reduced, and the turbine hall crane is available for other uses.

Assembled sections (Figure 26) are shipped with the rotor installed, diaphragms and other parts installed and aligned, and the shell “hot” bolted. In some cases, the front standard can be included as part of the shipment.

Procedures to facilitate the installation of these sections have been prepared and are derived from GE’s vast experience with the installation of shipped assembled sections for single and multi-casing designs for industrial and combined-cycle applications. To date, the largest unit shipped assembled has been the high and intermediate pressure sections of two 600 MW four-casing designs.

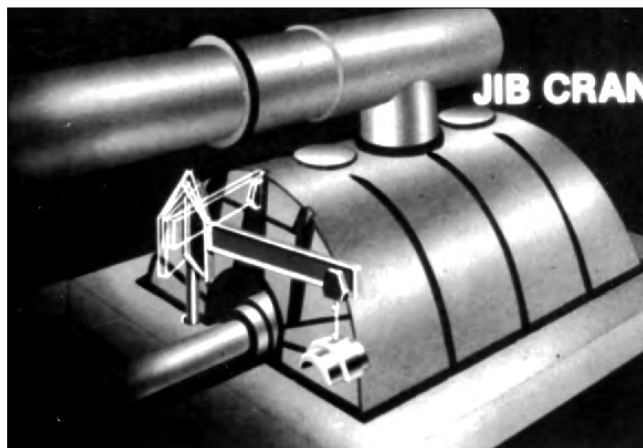

GT20480

Figure 25. Jib crane for bearing maintenance

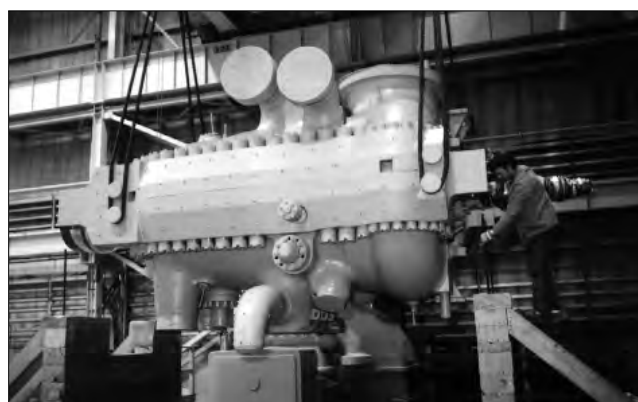

RDC26298-4-12

Figure 26. Shipped assembled HP/IP

CONCLUSION

GE offers a full range of steam turbine-generators for both fossil-fueled and nuclear 50 and 60 Hz applications. Many basic design features are the result of an overall consistent design philosophy that emphasizes efficiency, reliability, and maintainability. Many years of development effort have gone into the present product line and it is expected that this evolutionary process will continue in the future.

REFERENCES

1. Cofer, IV, J.I., Koenders, S., and Sumner, W.J., Advances in Steam Path Technology, GER-3713C, 38th General Electric Turbine State-Of-The-Art Technology Seminar, August 1994.
2. Moore, J.H., High Power Density™ Steam Turbine Design Evolution, GER-3804, 38th General Electric Turbine State-Of-The-Art Technology Seminar, August 1994.
3. Retzlaff, K.M., and Ruegger, W.A., Steam Turbines for Ultrasupercritical Power Plants, GER-3945, 39th General Electric Turbine State-of-the-Art Technology Seminar, August 1996.

LIST OF FIGURES

- Figure 1. Double-flow, low-pressure rotor with 42-inch/1067 mm last-stage buckets
- Figure 2. High power density–last-stage bucket impact
- Figure 3. Fossil turbine arrangements
- Figure 4. Two-casing, single-flow steam turbine
- Figure 5. Two-casing, double-flow steam turbine with shell-mounted valves
- Figure 6. Two-casing, double-flow steam turbine with off-shell valves
- Figure 7. Three-casing, four-flow steam turbine
- Figure 8. Three-casing, four-flow steam turbine
- Figure 9. Four-casing, four-flow steam turbine
- Figure 10. Five-casing, six-flow steam turbine
- Figure 11. Four-casing, four-flow, double-reheat steam turbine
- Figure 12. Ultrasupercritical steam turbine
- Figure 13. Nuclear turbine arrangements
- Figure 14. Six-flow nuclear steam turbine
- Figure 15. Ideal stage efficiency as a function of velocity ratio for impulse and reaction stage designs
- Figure 16. Typical impulse stages, wheel-and-diaphragm construction
- Figure 17. Typical reaction stages, drum rotor construction
- Figure 18. Tip leakage for impulse and reaction stages
- Figure 19. Root leakage for impulse and reaction stages
- Figure 20. Advanced three-dimensional aero stages
- Figure 21. Arrangement of opposed-flow, high-pressure and intermediate-pressure sections
- Figure 22. Effect of admission modes and throttle pressure programs on heat rate
- Figure 23. Method of location of stationary components
- Figure 24. Crossover expansion joint
- Figure 25. Jib crane for bearing maintenance
- Figure 26. Shipped assembled HP/IP



John K. Reinker

John K. Reinker joined GE's Power Generation Business in 1984 as a Steam Turbine Engineer. He worked in several design offices culminating in his assignment of Manager New Unit Design for Small and Large Steam Turbines. He was named to his current position of Product Line Leader — Large Steam Turbine in June 1996.



P. B. Mason

Paul B. Mason joined GE's Field Engineering Program in 1980 progressing to become a specialist in startup and controls. In 1989 he joined the Steam Turbine Application Engineering responsible for all technical aspects of proposal engineering for new industrial, combined cycle and central power plant steam turbine generators, becoming the Technical Leader of the group in 1996. Paul graduated from Southampton University in England with a B.S. in Mechanical Engineering in 1977.