

# Industrial Steam Turbines

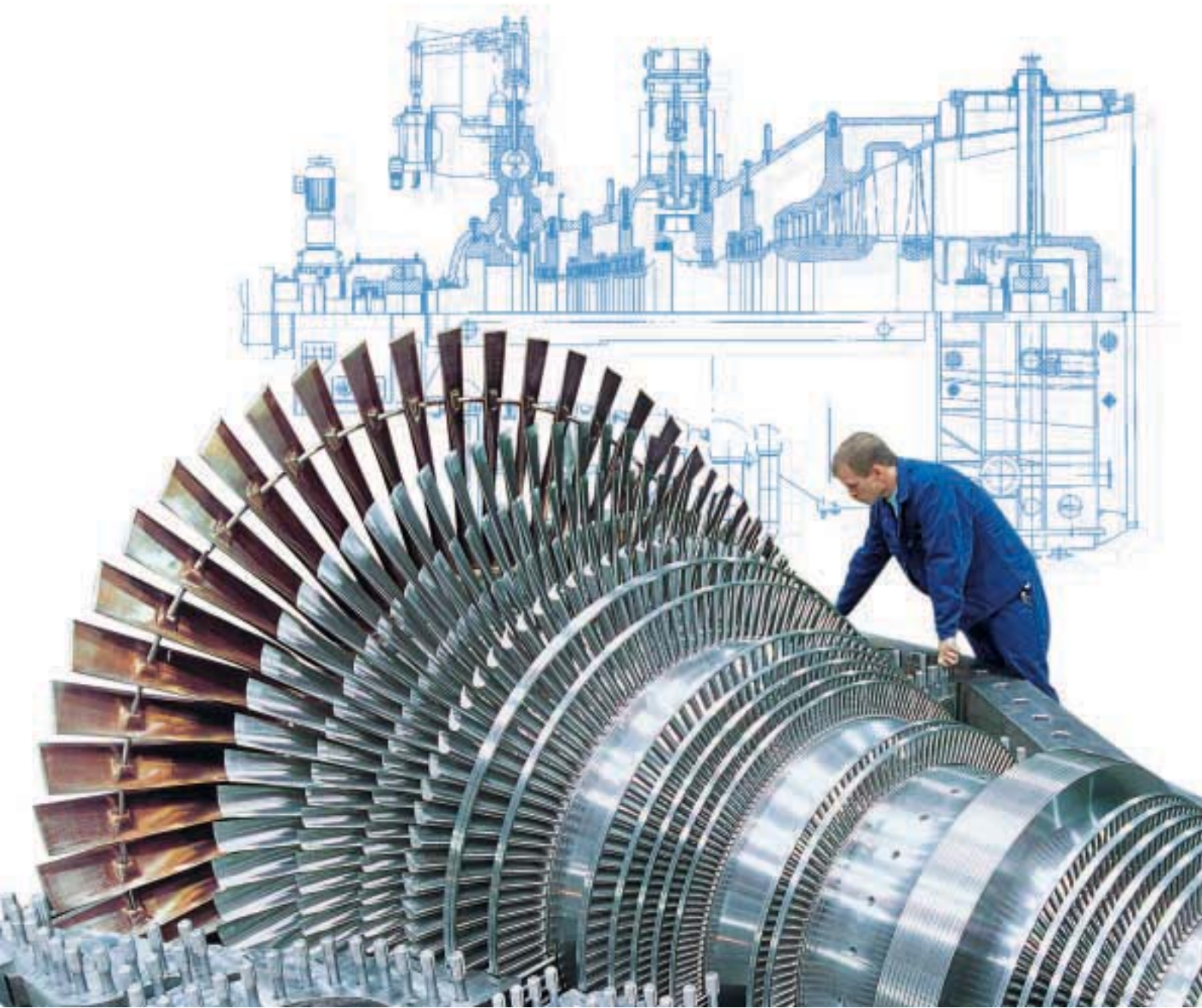

## Product Range

MAN TURBO offers a highly comprehensive range of steam turbines with proven performance for industrial applications as well as municipal power utilities.

Our core competence is the delivery of complete turbomachinery trains for industrial processes and electrical power generation including auxiliary equipment such as:

- condensing units
- oil supply systems
- thermal and acoustic insulation
- base frames and steel foundations.

MAN TURBO's range of steam turbines is based on a modular system that allows standardised steam turbine components to be combined in order to meet a specific customer requirement. Proven steam turbine modules, that have demonstrated a high level of reliability in operation, constitute a fundamental element of the design.

The large variety of inlet, admission/ extraction and exhaust sections guarantee optimum matching to the client's requirements; condensing turbines can be provided with either a radial (top or bottom) or an axial exhaust. The MAN TURBO steam turbine series can accommodate powers up to 120 MW and speeds up to 14,000 rpm.

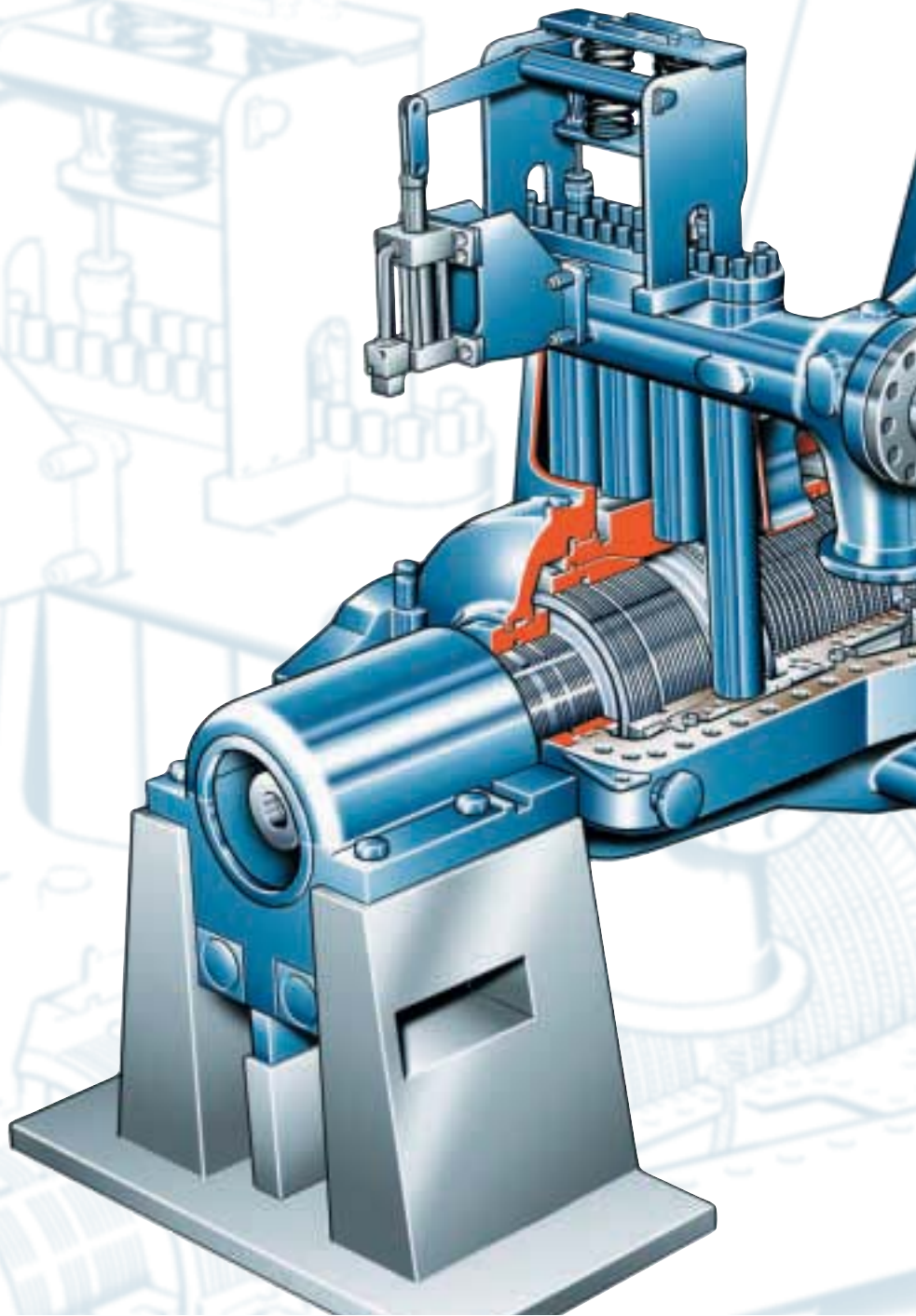

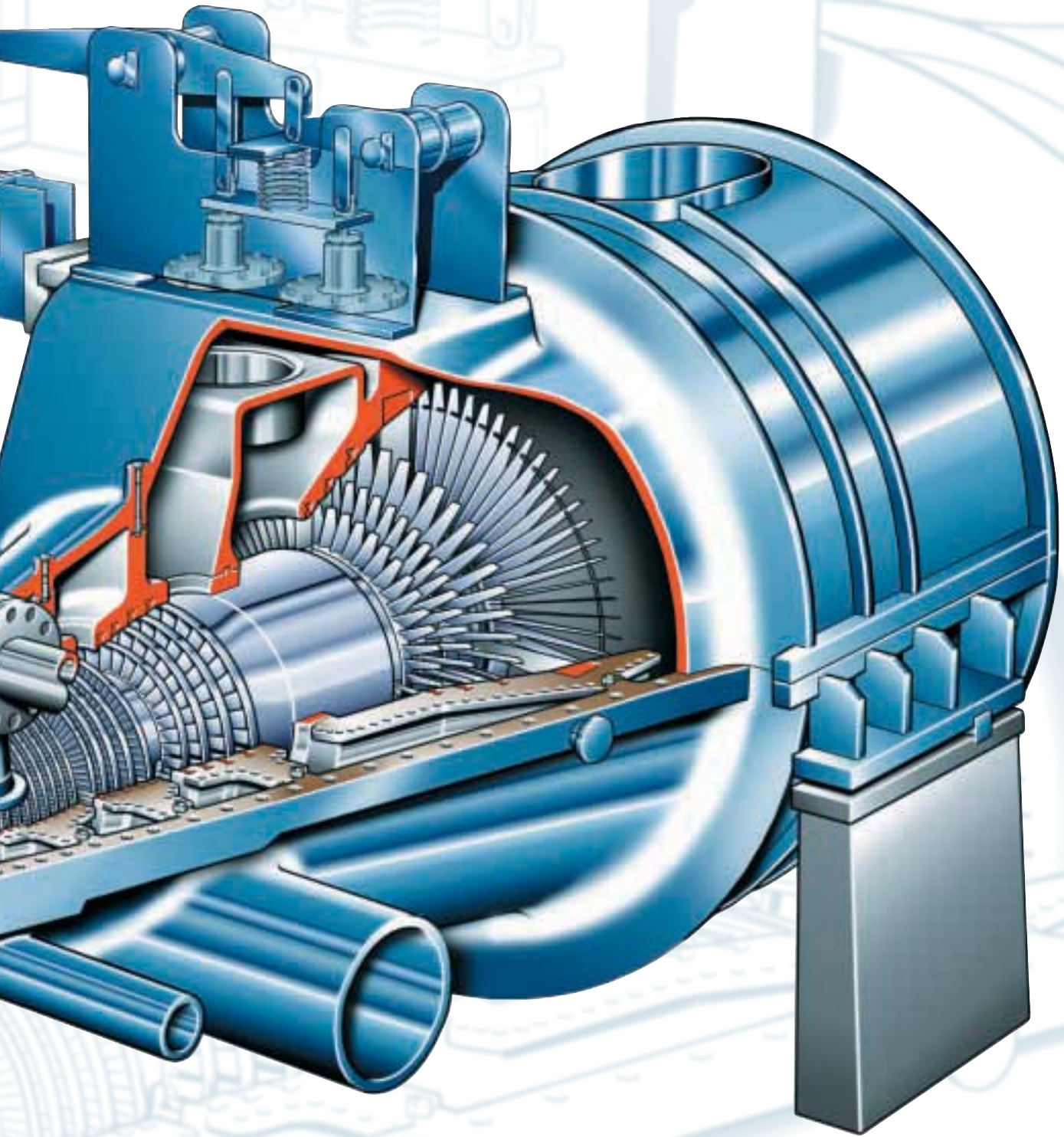

1 40 MW extraction condensing steam turbine with an axial exhaust



2 Three 38 MW condensing steam turbines for a 300 MW<sub>e</sub> combined-cycle power plant

3 Range of application

		Condensation steam turbines	Backpressure turbines
Power output	MW	5-120	5-120
Speed	rpm	up to 14.000	up to 14.000
Inlet pressure	bar	up to 130	up to 130
Inlet temperature	°C	up to 570	up to 570
Exhaust pressure	bar	up to min. 0.02	up to 40
Exhaust volume	m <sup>3</sup> /s	up to 1.300	





Innovations introduced by MAN TURBO in recent years include:

- High temperature inlet casings
- Transonic exhaust stages
- Axial exhaust casings
- Variable guide vanes for controlled extraction.

Process control and turbomachinery protection requirements are handled by the modular MAN TURBO turbolog® control & monitoring system. This digital system continuously guarantees safe and reliable plant operation.

MAN TURBO provides innovative solutions for industrial applications. The following business areas are typical for our products:

- Chemicals/Petrochemicals
- Refineries
- Oil & Gas
- Fertilizers
- Pulp & Paper
- Steel production
- Food processing
- Pharmaceuticals
- Municipal power generation.

Optional supplies and services include:

- Foundation calculations
- Mechanical running tests at MAN TURBO for steam turbines or complete turbomachinery trains
- Erection, commissioning and trial plant operation
- Training of operational staff.

To maintain our well-developed global customer relationships, MAN TURBO's service center is available 24 hours a day with nearly 100 years of sound experience in the steam turbine industry.



4 Steam turbine generator set

5 "turbolog® DSP" control and protection system



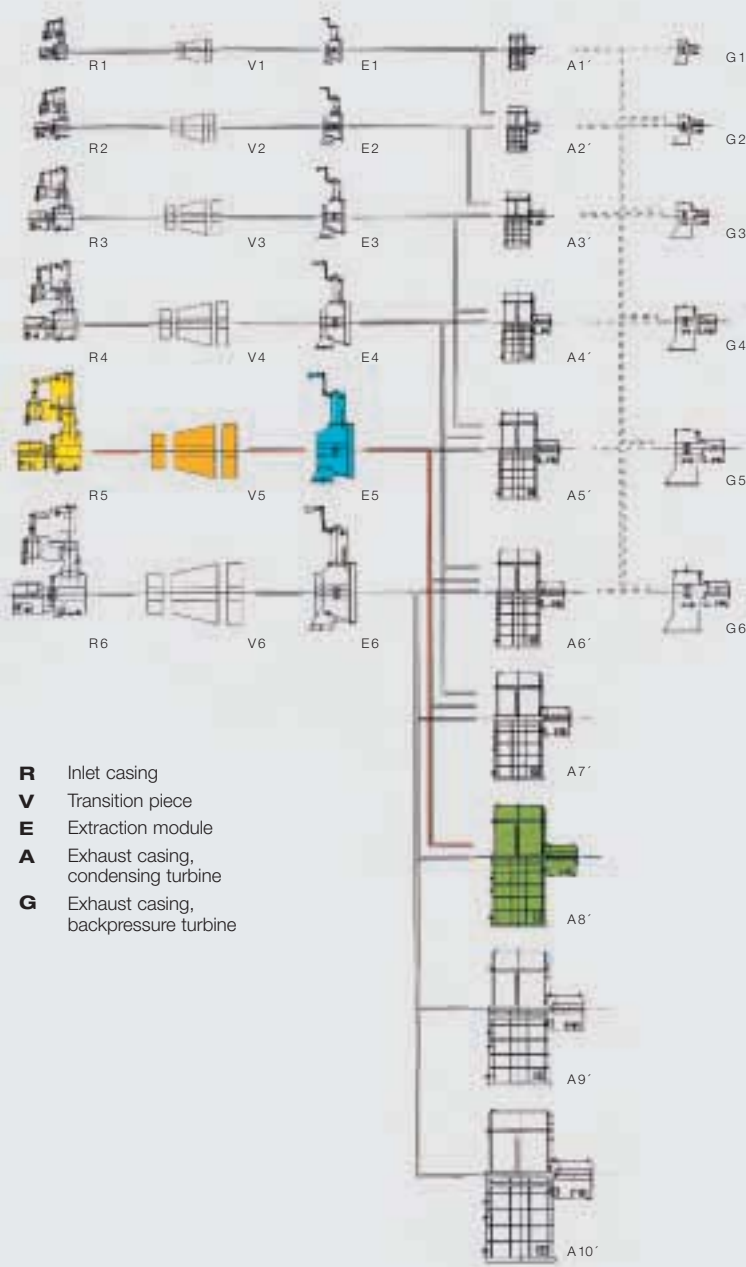

6 Modular design system

**Flexibility:**

**Modular Solutions**

The modular design of MAN TURBO's steam turbines builds the base for optimum efficiency under all operating conditions.

Standardised modules are available for key turbine components, such as bearing housings, inlet casings, control stages and exhaust ducts. Furthermore, the modular system includes standardised bleed, extraction and admission sections. All this results in mature design of the turbine with high flexibility regarding the layout of casing sizes, number of stages, rotor type and distribution of the nozzle groups.

Usually each turbine MAN TURBO manufactures is tailor made. In order to minimise the risk of unplanned shut-down periods, the modules are derived from thoroughly tested components that have been in operation for thousands of hours with proven reliability and availability.

Fig. 6 shows the different module groups with the options for combining these in a line diagram; one possible combination from the MAN TURBO module system is illustrated in Fig.7.

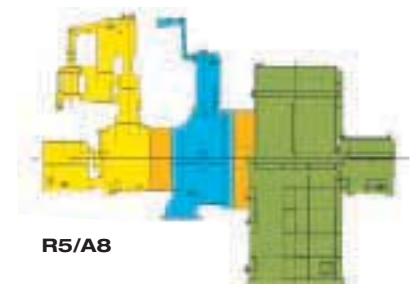

7 Example of an extraction condensing turbine derived from the module system

## Steam Turbine Types:

### Condensing Turbines

The MAN TURBO condensing steam turbine features a horizontally split main casing of cast steel; the exhaust casing is a fabricated construction which in turn is welded to the upper and lower part of the main casing.

One advantage of this design is that sealing problems, that may occur with cross partition joints, are completely eliminated, hence power losses are kept to a minimum.

The turbine fixed point is located at the exhaust casing support. The rotor fixed point relative to the turbine casing is the trust bearing housing at the live steam end.

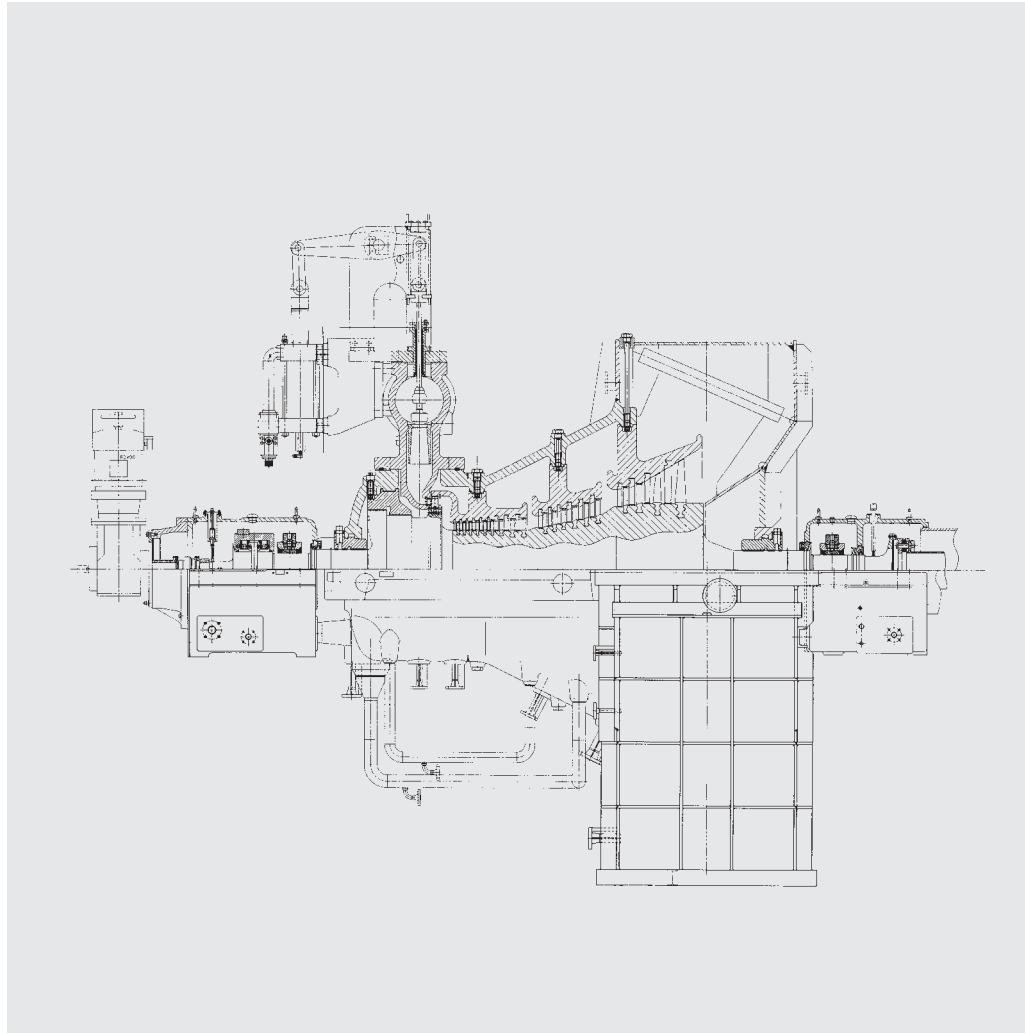

8 Sectional drawing of condensing steam turbine



9 Condensing steam turbine driver for an axial compressor



### Backpressure Turbines

The turbine features a single horizontally split cast casing incorporating the control stage as well as the transition and exhaust casing modules.

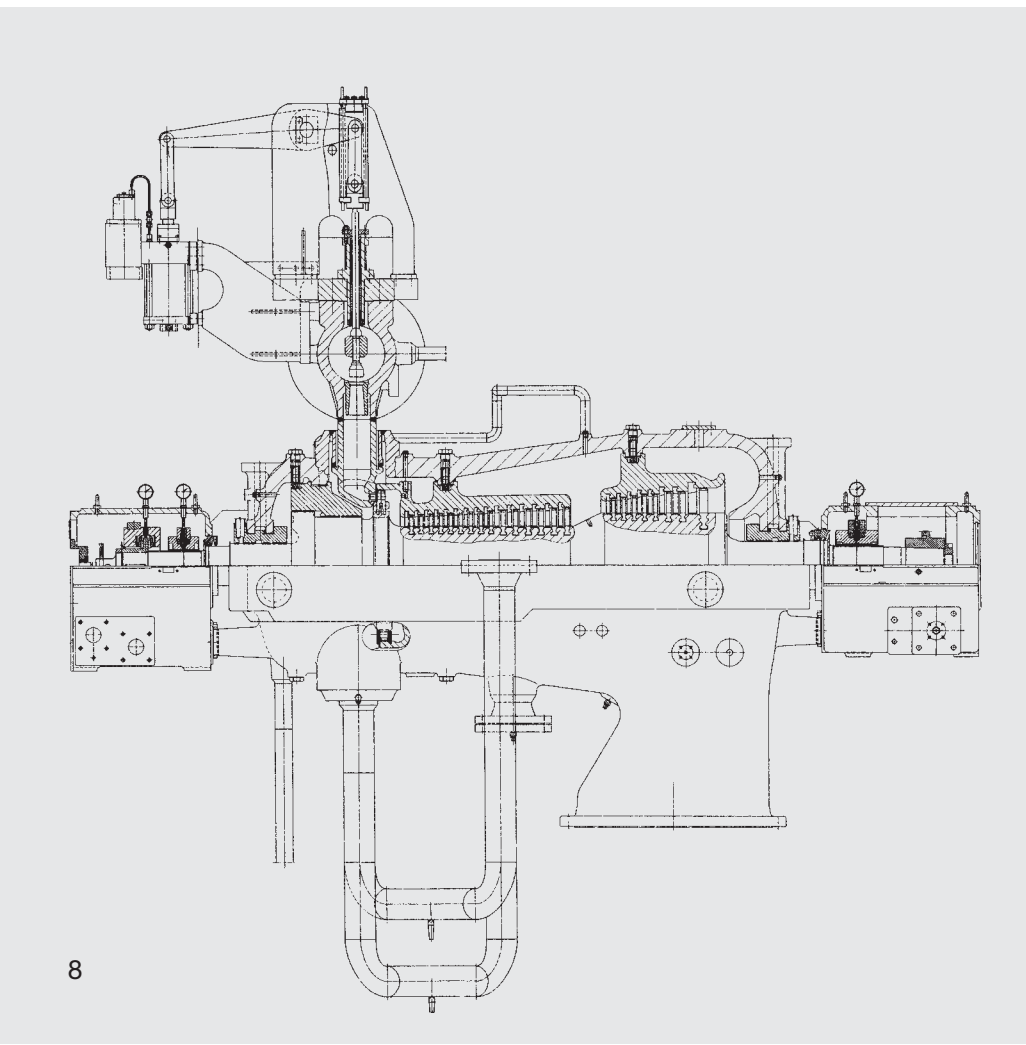

10 12 MW backpressure turbine

11 Sectional drawing of a backpressure turbine

## Extraction Turbines

Extraction steam turbines are designed to operate and control the client's steam networks using defined steam parameters.

Depending on the mode of operation, quantity of steam and pressure, three different methods of extraction control are possible:

- extraction control stage
- overflow throttle valve
- variable guide vanes.

The valves of an extraction control stage are located in the upper part of the casing. The extraction nozzles can be arranged downwards or towards the side. The minimum cooling steam flow rate for the low-pressure blading is also ensured at the maximum extraction rate.

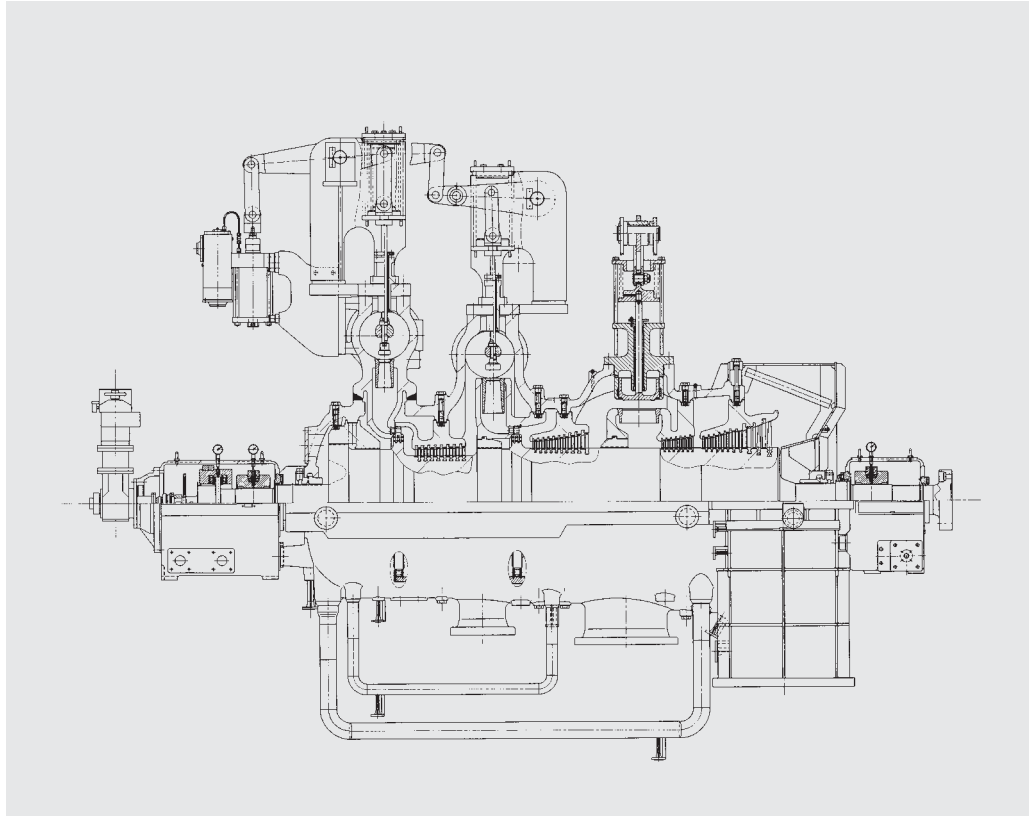

**12** Variable guide vanes in open position

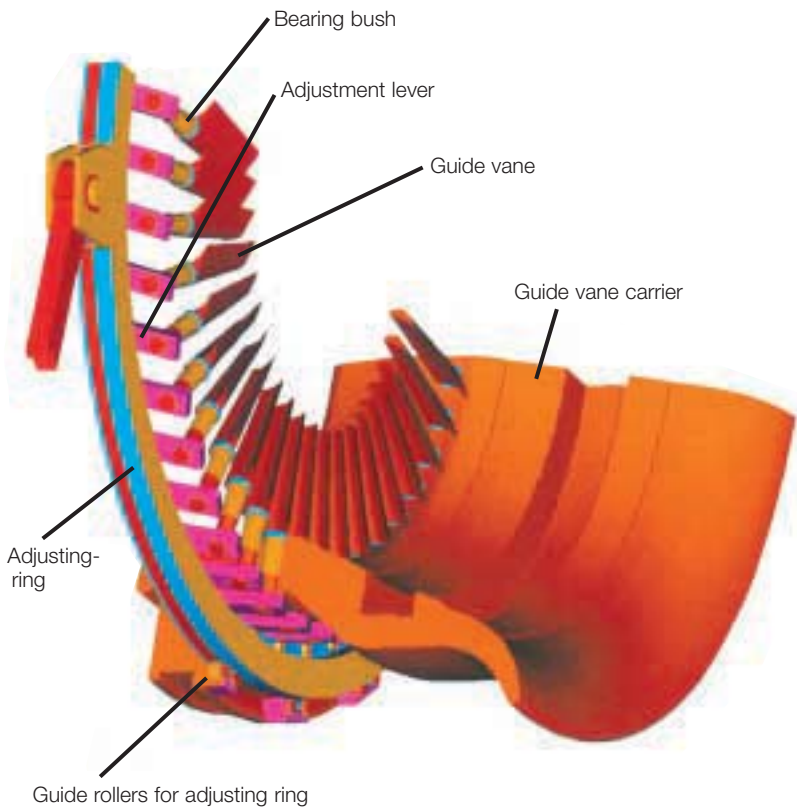

**13** Sectional drawing of a double extraction condensing steam turbine, the first is a controlled extraction with control stage, the second extraction uses an overflow throttle valve.

**14** 25 MW double-extraction condensing steam turbine



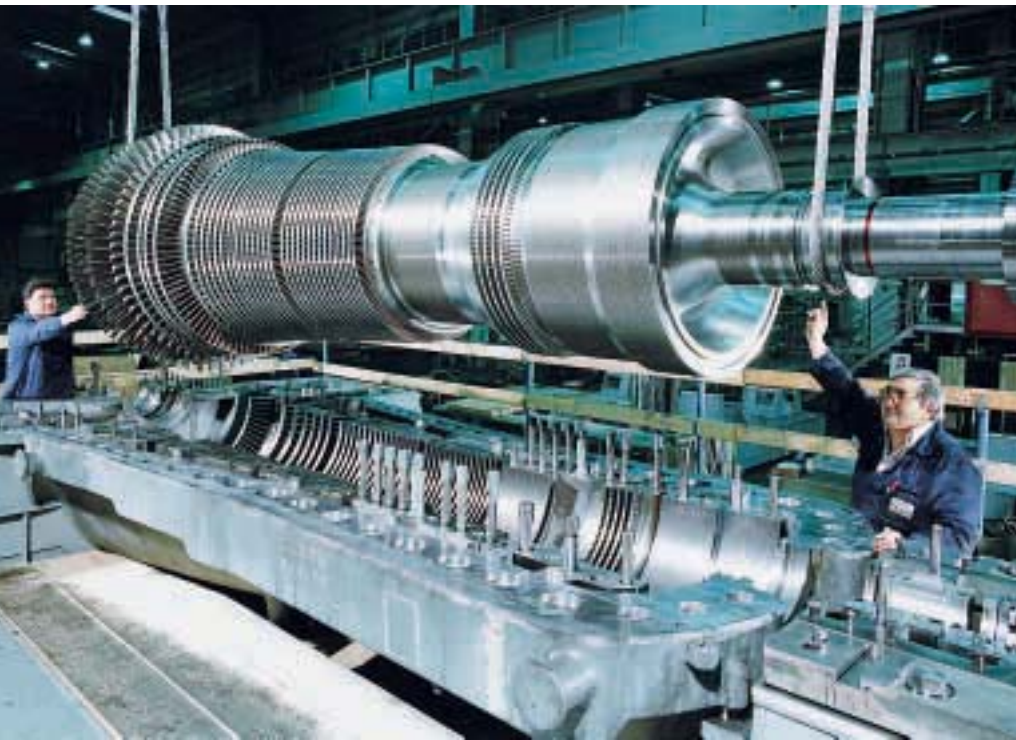

**Steam Turbines with Central Admission**

Central admission turbines are used in particular for large power plant units with maximum efficiency requirements.

Machines of this type are distinguished by their extremely low leakage steam losses at the balance piston.

15 Central admission turbine during assembly

16 45 MW steam turbine for a CHP plant

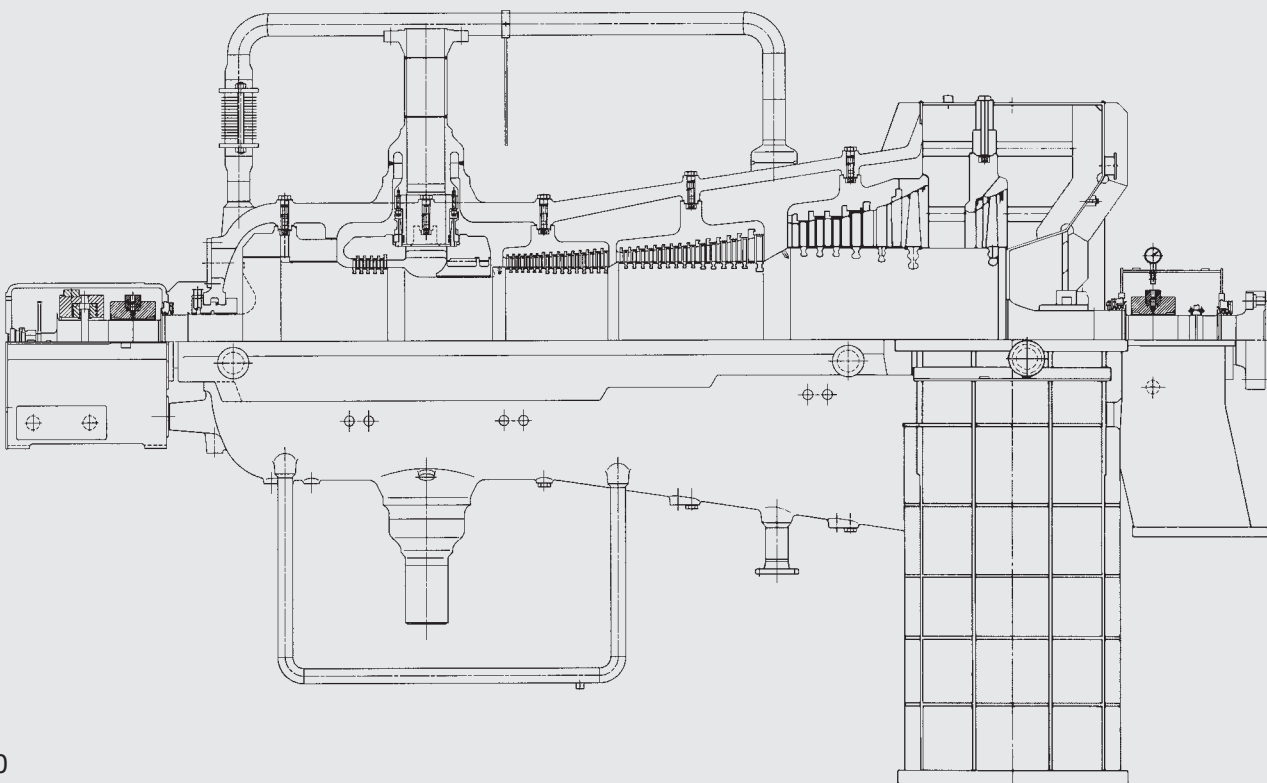

**Reliable and Economical:**

**The Design**

### **Axial Exhaust**

MAN TURBO steam turbines with an axial exhaust flow to the condenser offer an economical alternative to conventional turbines which have the exhaust duct in lower casing half and consequently require a mezzanine arrangement.

The in-line arrangement with an axial exhaust allows significant savings in civil works.

### **Casing**

All steam turbines made by MAN TURBO have a horizontally split casing of cast steel. The guide vane carriers are supported thermoelastically inside the main casing.

State-of-the-art materials are used for the casing and the guide vane carrier.

The partition joint bolts are uniformly preloaded by an hydraulic tightening device without the application of any torque. Bolt stresses can be measured directly during the assembly and the device also allows simultaneous tightening of the bolts.

A further advantage is that assembly times are shortened.

**17** Condensing steam turbine with axial exhaust on transport frame



**18** Pre-tensioned partition joint bolts using hydraulic tensioning device

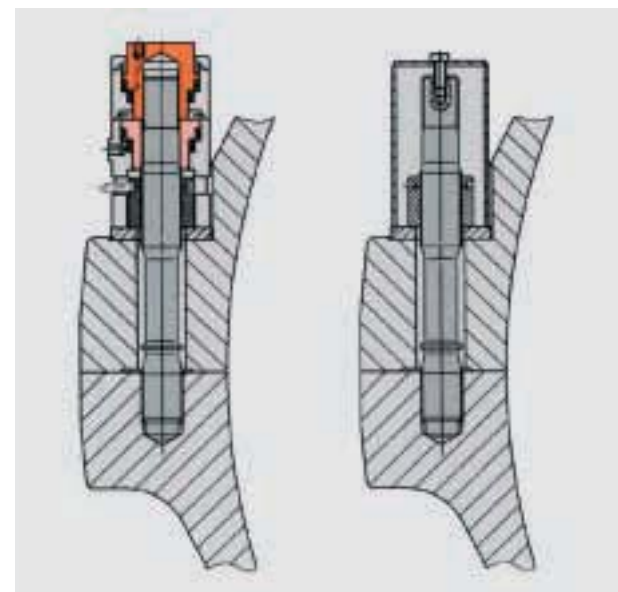

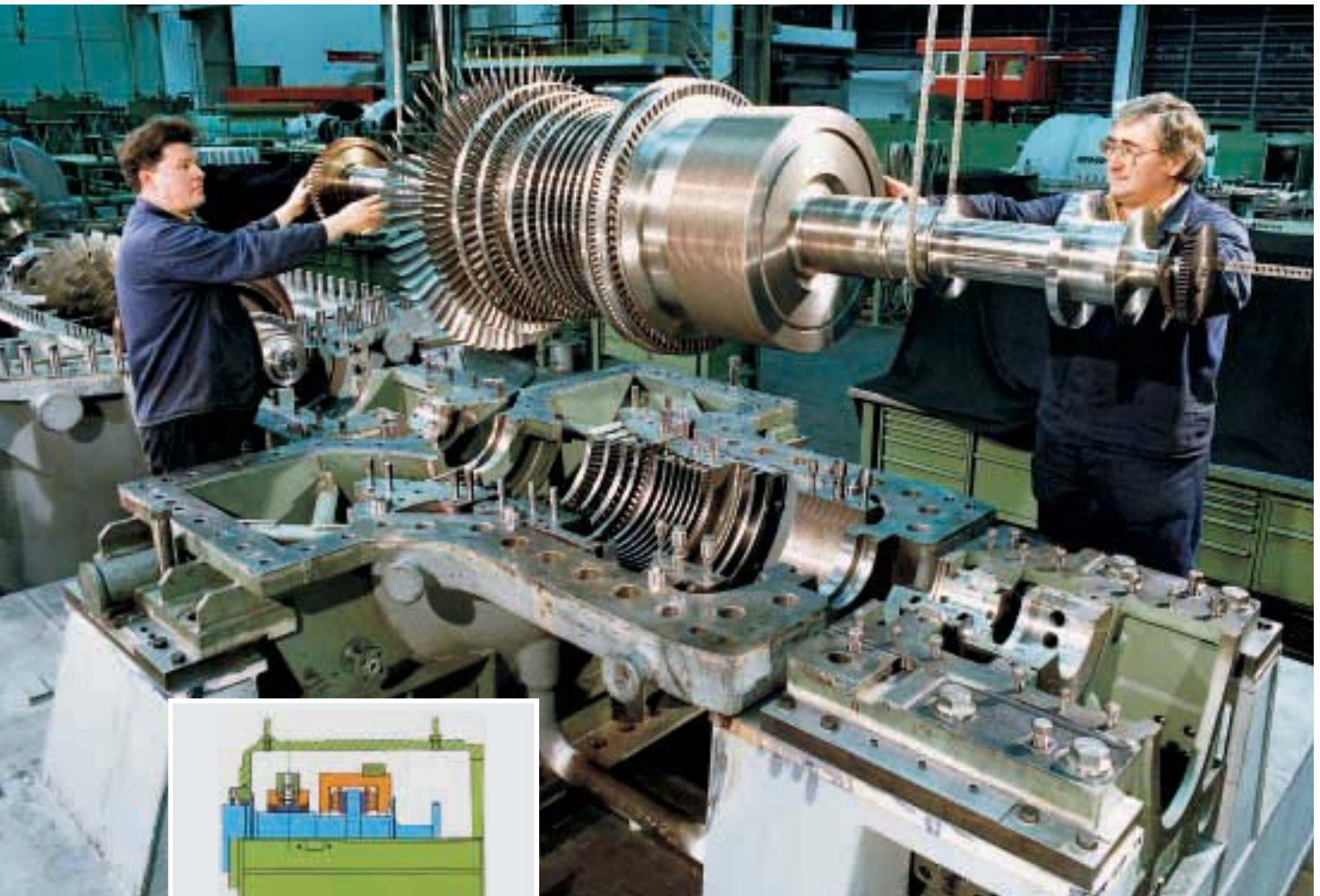

19 Assembly of a condensing steam turbine

20 Sectional drawing of bearing housing showing bearing arrangement

### Bearing housing and bearings

The modularised design system includes a standard range of bearing housings for the live steam and exhaust sides of the turbine. The housings are made of cast iron and located on the centre-line of the turbine from pedestals on the baseframe.

Several journal bearing diameters are available for each size of bearing housing and are designed either as multi-lobe (lemon shaped) or tilting pad bearings.

The axial bearing assembly is arranged separately from the journal bearing in the live steam side bearing housing. The thrust bearing is designed as a double-acting segmental bearing for both directions of rotation and thrust.

Self-balancing thrust bearing designs can also be used.

In the case of steam turbines featuring an axial exhaust, the rear bearing housing is an integral part of the exhaust casing.

## Actuators and Valves

The actuators used in MAN TURBO steam turbines are distinguished by their excellent control characteristics, short response times and insensitivity to inlet pressure fluctuations.

The control valve design is characterised by:

- optimum part-load efficiency (minimal throttle losses) due to nozzle group control
- flow-optimised valve design due to diffuser configuration
- seizure of the valve stem is avoided due to continuous movement of all four valves during operation
- actuator spindle leakage minimised as the two spindles supporting the bar-lift beam are provided with graphite packings with leakage steam removal.
- linear characteristic (valve stroke versus steam throughput) due to optimised plug form and stroke overlap between valves
- high wear resistance due to the use of heat-resistant steels for valve spindles, lifting beam, valve cones and diffusers, with additional surface hardening of spindles and valve stems.



**21** Steam turbine upper section with flanged steam chest

Fig. 22 shows the arrangement and function of the valve control system on MAN TURBO steam turbines; the trip valve and control valves are opened by oil pressure.

The hydraulic actuator moves the two spindles and thereby the lifting beam; the control valves are attached to the lifting beam and open & close gradually in line with their individual stem lengths.

The control valve position is determined by the speed governor.

In the event of an emergency trip, load shedding or oil pressure failure, the spring force ensures that the entire system, control valves and trip valve, close, tripping the turbine in the minimum of time.

The trip valve is located to the side of the control valve casing and can be tested whilst the turbine is in operation. The steam strainer is also integrated into the trip valve housing and is easy to maintain.

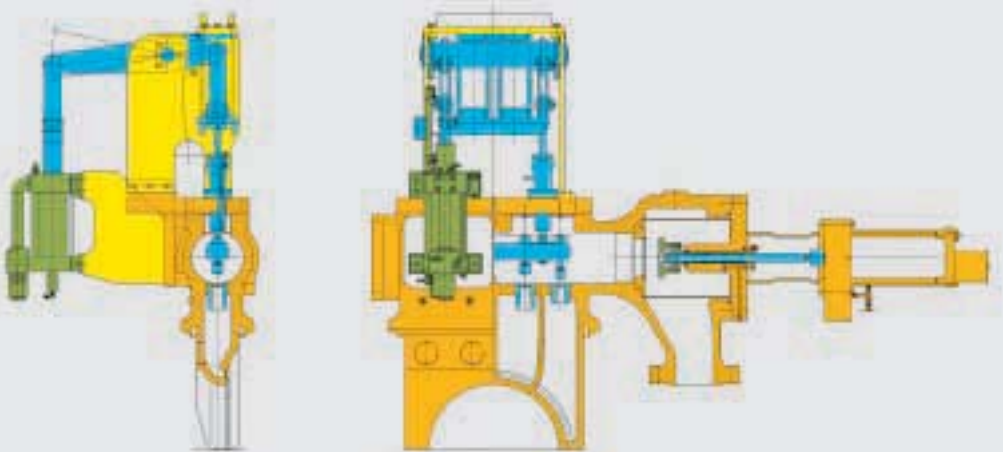

**22** Valve chest with control valves and trip valve

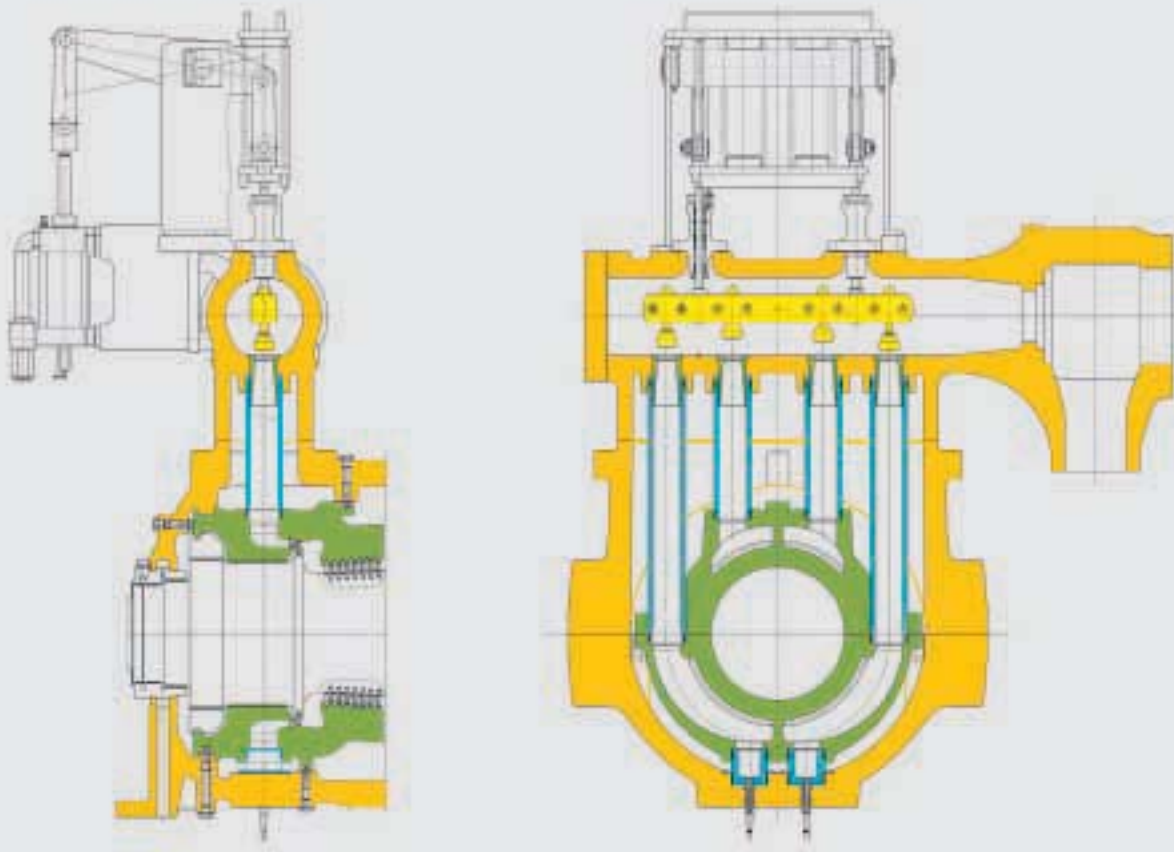

**23** Full admission steam chest design for high live steam conditions (temperatures up to 570°C)

### Inlet casing

Two types of inlet casing are available:

### Standard Casing

The standard inlet casing is an economically efficient, proven design for live steam temperatures up to 500 °C. The complete control valve housing assembly is connected to the main turbine casing using a flanged or welded joint. Control stage nozzles are fitted in the upper section of the wheel chamber casing.

### High-temperature casing

For live steam temperatures up to 570°C, an internal casing admits steam to the upper and lower sections of the wheel chamber. This thermo-elastic double casing design ensures trouble-free operation with demanding live steam conditions and provides a high level of machine flexibility with changes in temperature and load.

## **Rotors**

All steam turbine shafts are single piece forgings and the choice of material depends on the requirements of the individual application. State-of-the-art materials guarantee that MAN TURBO turbines are highly reliable.

The shape of the rotor is matched individually to the steam path and is designed to ensure a long machine life. Safety margins relative to lateral & torsional critical speeds, take into account national and international standards, as well as MAN TURBO's own quality criteria.

Our production process and quality assurance system for steam turbine rotors meets the highest standards. Thermal stability testing follows pre-machining of the rotor. This measure, in conjunction with high-speed balancing of the bladed rotor assembly in our own balancing facility, assures maximum availability and smooth running during operation.

In order to compensate the axial thrust which arises in reaction machines, MAN TURBO steam turbines are equipped with a balancing drum; the residual thrust is compensated by the axial bearing.

## **Shaft Glands**

Shaft glands in the turbine casing are sealed by means of contact-free labyrinth seals; the labyrinth strips are caulked into easily replaceable seal bushings.

**24** Rotor of a steam turbine for a compressor drive application

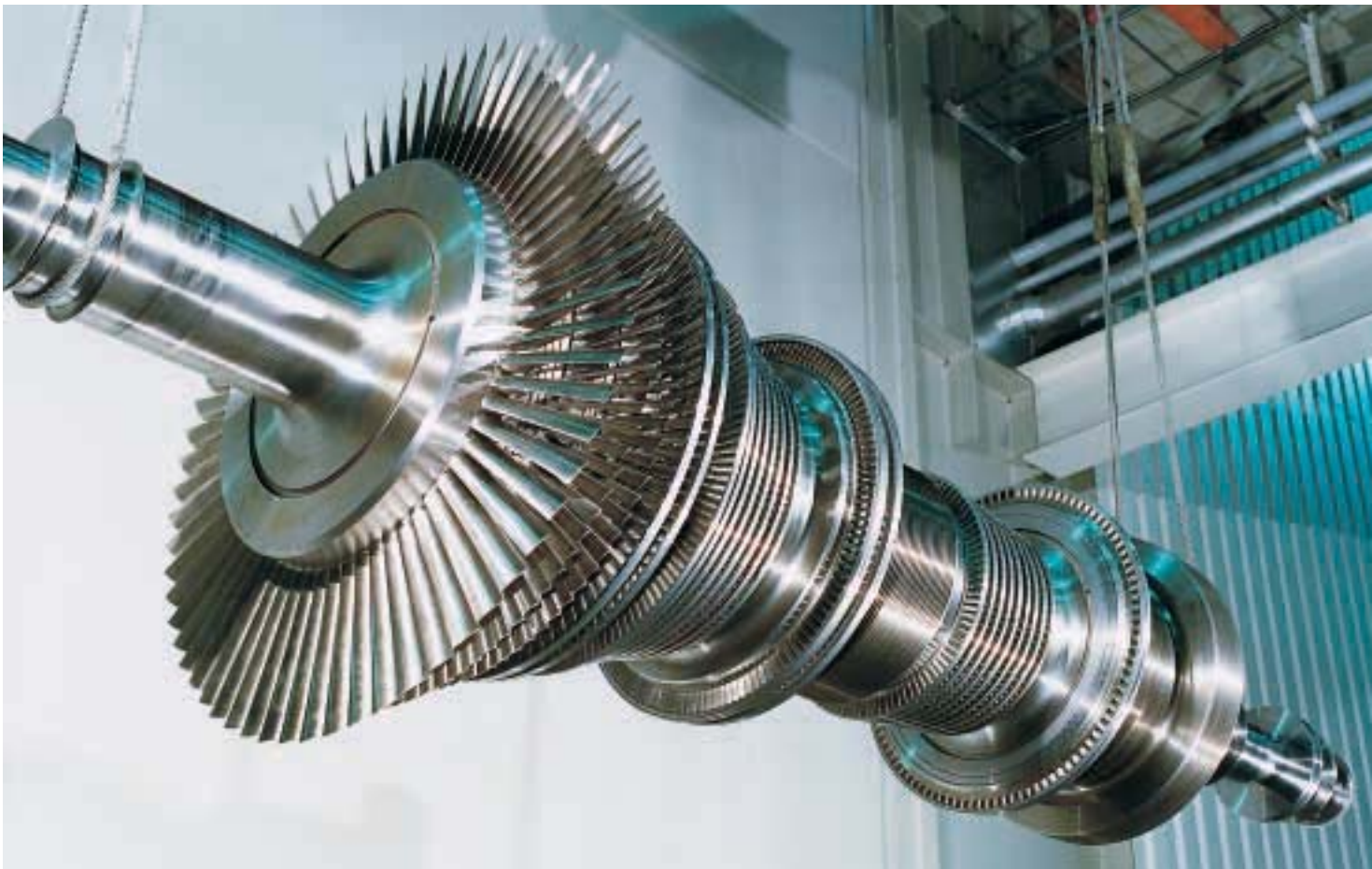



25 Low-pressure blading

26 Intermediate-pressure blading



## Blading

Similar to the modularised casing elements, MAN TURBO has standardised stator and rotor blades in a variety of blade series. The profile system, which is graduated according to chord length and stagger angle, is optimally coordinated with regard to aerodynamic and strength factors. The complete blade family allows a turbine to be configured so that over all possible operating speed ranges blade vibration resonance is excluded.

All guide vanes and rotor blades are manufactured from corrosion-resistant chromium steels.

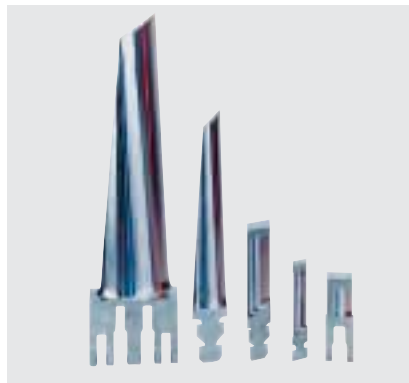

27 Blade family

## Control Stage

A single impulse stage or a Curtis wheel is used to control the turbine. The rotor blades are milled complete with integral shrouds from a single piece and in the area of the shrouds laterally caulked damping wires are inserted for optimum vibration damping. The radial gap between the rotor blade shrouds and the guide vane carrier is sealed by means of labyrinth sealings strips to minimise losses.

On single impulse control stages the blades are attached to the rotor by a pinned root, whereas for Curtis wheel control stages double T-roots are used.

## High-pressure/ Intermediate-pressure blading

The blades used in these sections have a drop-shaped reaction profile with a relatively large radius on the leading edge. This makes the profile insensitive to variations in angle of incidence over a wide operating range and ensures good profile efficiency, even in the part-load and overload range.

The milled shrouds of the rotor blades reduce losses at the blade tip, thereby increasing efficiency. The shroud gap is sealed against the guide vane carrier by labyrinth seals. T-root, double T-root or pinned root fixings are used to attach the rotor blades, depending upon the mechanical load.

## Low-pressure blading

In the low pressure section, above a certain ratio of blade length to hub diameter, the rotor blades have twisted profiles.

These blades are designed as free-standing, tapered blades with or without damping wires. The modular system includes T-root, double T-root and pinned root attachment options for the low-pressure blades. Surface hardening is also available, depending upon the application.

28 Control stage





### Guide vanes and guide vane carriers

Guide vane carriers are suspended thermoelastically in the turbine casing and are split horizontally.

Furthermore, the guide vane carriers are located axially by a shoulder in the turbine casing. In the horizontal plane, they are supported at the casing split joint by alignable spigot bolts and adjusted vertically by eccentric bolts.

These fixing elements permit free expansion of the vane carrier in the radial direction and enable a centring fit under all operating conditions. The symmetrical design ensures dimensional stability even in the event of rapid temperature changes to maintain constant radial clearances.

The guide vanes are fitted into the guide vane carrier by means of a hook root and are provided with a riveted shroud.

Grooves in the low-pressure guide vane carrier remove free water via holes to the exhaust casing and so, directly on to the condenser. This feature substantially reduces the free-water in the wet section of our condensing turbines and reduces exhaust stage erosion to a minimum.

29 Guide vane carrier

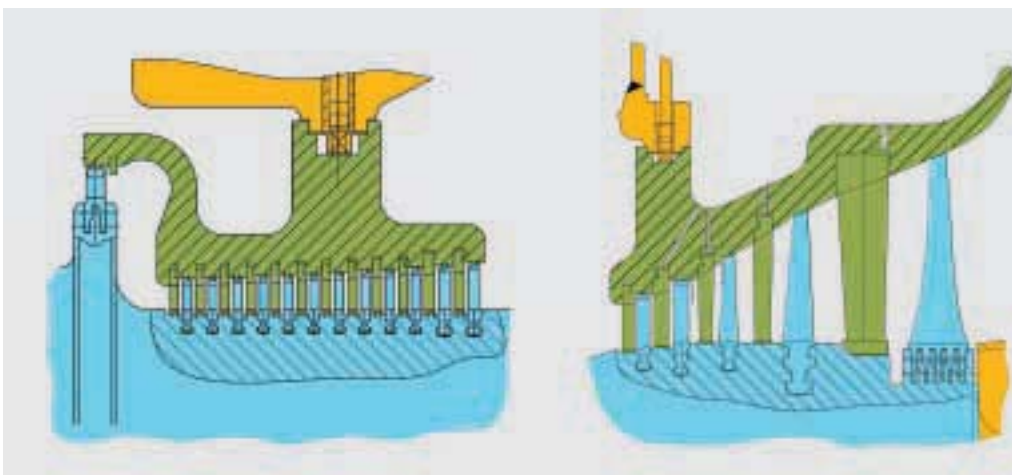

30 Guide vane carriers for high-pressure and low-pressure sections

## Applications

The design of steam turbines used for **mechanical drive application** such as pumps, blowers or compressors, must be flexible to adapt to the process requirements; flexible design solutions are therefore particularly important.

The ability to operate over a wide range of speeds makes the steam turbine an ideal choice to drive a variety of process machinery.

In addition the steam parameters required by the process are provided via the extraction, admission and bleed connections on the turbine.

MAN TURBO's core competence includes planning, design, construction, delivery, erection and commissioning of complete turbomachinery sets, comprising one or more steam turbines, compressors and, where applicable, expanders. Support systems and auxiliary units required for normal operation usually from part of our supply.



31 Compressor train with condensing steam turbine

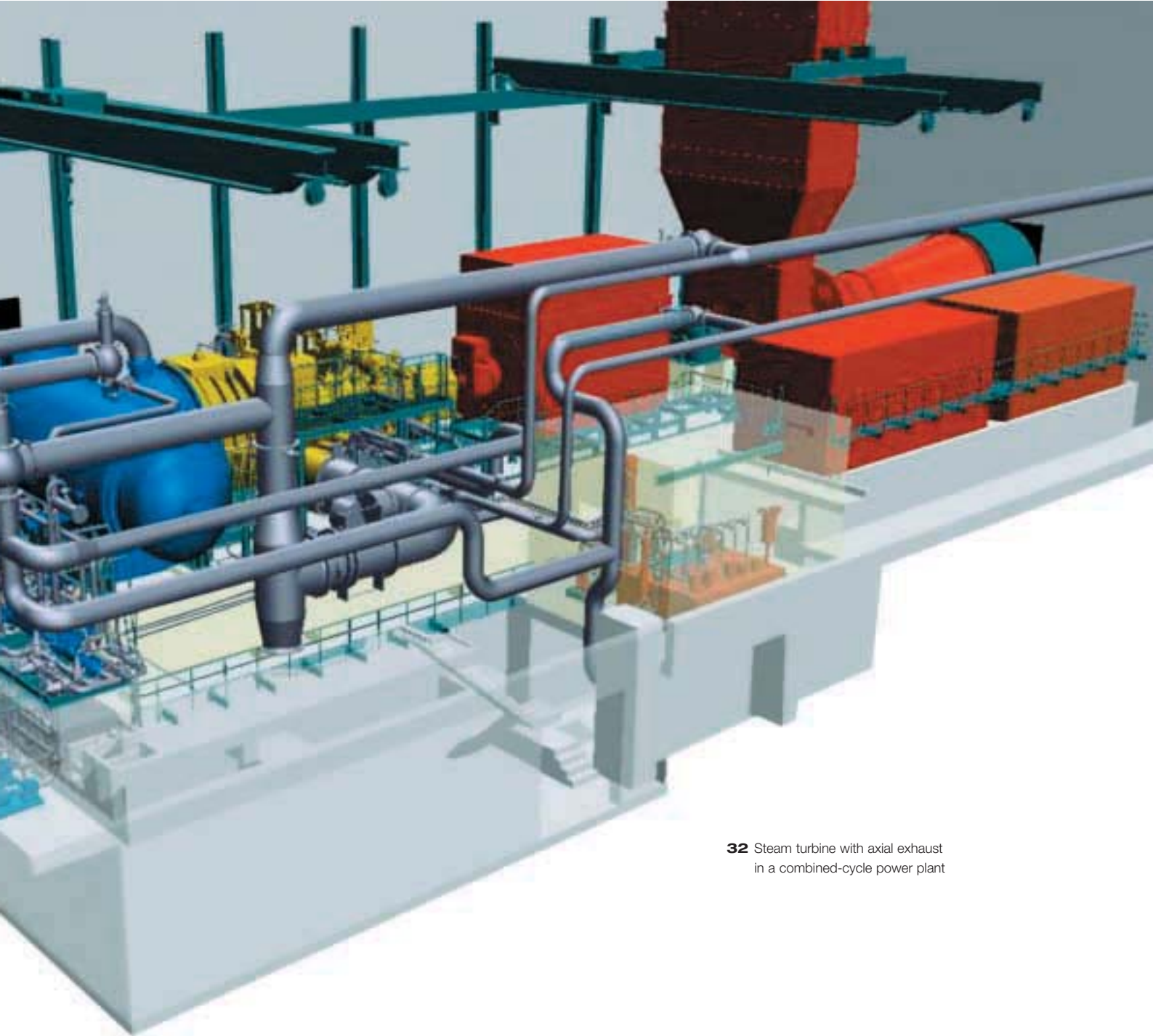

**32** Steam turbine with axial exhaust  
in a combined-cycle power plant

### **Generator drives**

We supply condensing and backpressure steam turbines up to power outputs of 120 MW to drive electrical generators.

These are used for municipal power generation as well as for industrial power plants. MAN TURBO steam turbines are distinguished particularly by their economic integration into heat & power cogeneration systems.

Steam turbines are also used in combined-cycle power generation applications where waste heat of the gas turbine exhaust gas is recovered in order to generate steam for the steam turbine. This technology has enormous market potential and is environmentally friendly, as maximum levels of electrical efficiency are achieved.

**Based on our continuous steam turbine development program, we are in an excellent position to deliver innovative and economic solutions for our customers worldwide**



MAN Turbomaschinen AG  
GHH BORSIG  
Steinbrinkstrasse 1  
46145 Oberhausen / Germany  
Phone +49. 208. 6 92-01  
Fax +49. 208. 6 92-20 19  
[www.manturbo.com](http://www.manturbo.com)

MAN Turbomaschinen AG  
GHH BORSIG  
Egellsstrasse 21  
13507 Berlin / Germany  
Phone +49. 30. 43 01-03  
Fax +49. 30. 43 01-28 41

In the interests of technical progress,  
subject to change without notice.  
Printed in Germany.  
May 2002

TURBO 945 e 0502 5 ba

MAN Turbomaschinen AG  
Schweiz  
Hardstrasse 319  
8023 Zurich / Switzerland  
Phone +41. 1. 278-22 11  
Fax +41. 1. 278-29 89

MAN Turbomacchine S.r.l.  
De Pretto  
Via Daniele Manin 16/18  
36015 Schio (VI) / Italy  
Phone +39. 0445. 6 91-5 11  
Fax +39. 0445. 5 11-1 38