



THE HIGHWAYS AGENCY

TD 39/94



THE SCOTTISH OFFICE DEVELOPMENT DEPARTMENT



THE WELSH OFFICE
Y SWYDDFA GYMREIG



THE DEPARTMENT OF THE ENVIRONMENT FOR
NORTHERN IRELAND

The Design of Major Interchanges

Summary: This standard augments TD 22/92. It sets out the Design and Assessment Procedures to be used for Major Interchange Design. It also sets standards for those features which are likely to be required in major interchanges and for which no current standards are available.

REGISTRATION OF AMENDMENTS

| Amend No | Page No | Signature & Date of incorporation of amendments | Amend No | Page No | Signature & Date of incorporation of amendments |
|----------|---------|---|----------|---------|---|
| | | | | | |

Registration of Amendments

REGISTRATION OF AMENDMENTS

| Amend No | Page No | Signature & Date of incorporation of amendments | Amend No | Page No | Signature & Date of incorporation of amendments |
|----------|---------|---|----------|---------|---|
| | | | | | |

PART 4

TD 39/94

**THE DESIGN OF MAJOR
INTERCHANGES**

Contents

Chapter

1. Introduction
2. Design Procedure
3. General Layout Advice
4. Major Merges and Major Diverges
5. Operational Assessment
6. Examples of Upgrade Paths for Major Interchanges
7. References
8. Enquiries

1. INTRODUCTION

General

1.1 Standard **TD 22 (DMRB 6.2.1)** sets out the Overseeing Organisation's design standards and methodology for the geometric layout of grade separated junctions on trunk roads.

1.2 Advice Note **TA 48 (DMRB 6.2.2)** provides guidance on the principles for safety and traffic operation on which the Standard **TD 22 (DMRB 6.2.1)** is based.

1.3 This document provides guidance on the design of major interchanges including the expansion and improvement of existing interchanges and junctions beyond the scope of Standard **TD 22 (DMRB 6.2.1)** and Advice Note **TA 48 (DMRB 6.2.2)**. It follows research into major interchanges and high capacity highway corridor options, including use of link roads.

1.4 Major interchanges will generally be required at the intersection of motorways and major trunk roads where capacity is increased by carriageway widening. Major interchanges will, in many cases, be larger and more complex than the original junction.

1.5 Choice of location will often be severely restricted, compared with completely new construction. Layout options may also be restricted by adjacent development and other constraints. Management of traffic on existing roads will often play a significant part in the assessment of options and the planning of construction.

1.6 Solutions for major interchanges will often contain elements designed in accordance with Standard **TD 22 (DMRB 6.2.1)** and Advice Note **TA 48 (DMRB 6.2.2)** and it is therefore intended that this document be read in conjunction with them.

1.7 Due to the general larger size of major interchanges, consequential greater environmental impact and the number of factors to be considered, a more formalised assessment of options is required.

Scope

1.8 Recommendations are given on a design methodology and appraisal process for the comparison of alternative solutions.

1.9 New layouts are provided for major merges and major diverges to allow for three lanes joining or leaving the mainline. Merges and diverges larger than these are unlikely to be required due to the practical and operational limits on the maximum width of the combined carriageway. For dealing with very large turning movements, connection of interchange links to motorway link roads is likely to be required. Therefore the choice of motorway carriageway provision and major interchange layout will be an iterative process.

1.10 Operational and driveability assessments based on the decisions and manoeuvres required to negotiate alternative interchange layouts are included.

1.11 Examples of possible layouts, for the expansion, rearrangement or replacement of typical existing interchanges are illustrated, including consideration of connections to motorway link roads.

Implementation

1.12 This document should be used forthwith on all schemes for the construction and improvement of motorways currently being prepared, provided that, in the opinion of the Overseeing Organisation, this would not result in significant additional expense or delay progress. Design Organisations should confirm its application to particular schemes with the Overseeing Organisation.

Definitions

1.13 The terminology follows where possible the definitions contained in **BS 6100: Subsection 2.4.1** and Standard **TD 22 (DMRB 6.2.1)**.

1.14 The following additional terms have been defined for use in this document:

1.15 **Major merge:** A merge where three lanes join the mainline carriageway.

1.16 **Major diverge:** A diverge where three lanes leave the mainline carriageway.

Mandatory Sections

1.17 Sections of this document which form part of the standards the Overseeing Organisation expects in design are highlighted by being contained in boxes. These are the sections with which the designer must comply. The remainder of the document contains advice and enlargement which is commended to designers for their consideration.

2. DESIGN PROCEDURE

General Principles

2.1 This document relates primarily to the expansion or redevelopment of existing junctions and interchanges. Consideration of traffic management during construction is a fundamental requirement in providing a safe and economical construction. The scope for design will be constrained by the existing junction layout and also by development adjacent to the junction in many cases.

2.2 Each scheme shall be considered within the overall network strategy. This strategy shall include all network considerations including the degree of access to be provided and the omission of existing connections for the benefit of longer distance traffic or the environment.

2.3 Flow standards and the methodology of determining traffic flow levels is as specified in **TD 22 (DMRB 6.2.1)** and **TA 48 (DMRB 6.2.2)**. Consideration shall be given to network constraints and the use of constrained traffic models to avoid forecast traffic demand far above that which can be provided by the local network as it may be developed over the life of the proposed scheme.

2.4 A number of options should be considered and developed. The development of each option will be an iterative process. While all options should cater for the predicted design flows, the options for consideration should range from alternatives which have a minimal effect on existing traffic movements to those which provide the optimum final design. A decision framework including all the alternatives should be produced.

2.5 Consideration of all the major contributing factors included in the design methodology should be undertaken in the assessment to produce a solution which most closely meets the requirements while remaining value for money.

2.6 The requirements for incident management and maintenance operations are important considerations and include the provision of access routes and u-turn facilities for maintenance and emergency vehicles as well as additional widths of carriageway.

2.7 Network consistency and the use of standard features including signs and road markings over a route or within an area is also important. Drivers should not be surprised by rare features as they may carry an increased accident risk. Interchange simplicity and driver understanding are also relevant. The layouts must be appraised for the adequate provision of signing.

2.8 Through route continuity should be maintained where possible. The principal signed or through route should have priority and the secondary route should diverge on the left.

2.9 A program of sensitivity testing of the predicted turning flows should be undertaken to examine the consequences and costs of the flows in the design year being different from the predictions. Examples of sensitivity testing of flows are given in Appendix 3 of **TA 23 (DMRB 6.2)**.

| | RURAL STANDARDS | | | | URBAN STANDARDS | | | |
|----------------------|-----------------|---------|-----|-----|-----------------|---------|-----|-----|
| | 120 | 100 | 85 | 70 | 100 | 85 | 70 | 60 |
| Motorway/ AP Road | +++ | | | | +++ | | | |
| Link Road | +++++++ | | | | +++++++ | | | |
| AP Road | | +++ | | | | +++ | | |
| Link Road | | +++++++ | | | | +++++++ | | |
| Interchange Link | | | +++ | | | | +++ | |
| Slip | | | | +++ | | | | +++ |

Table 2/1: Interchange and Junction Element Design Speed Steps - kph

(This table is an interpretation of Table 4/2 in TD 22 (DMRB 6.2.1))

2.10 There is a requirement in **TD 22 (DMRB 6.2.1)** for link road and interchange link design speeds to be generally lower than the mainline. This reduction is one or two steps down from that provided for the mainline. Where constraints require interchange link design to be based on further reductions and the links are therefore significantly lower than driver expectation, advisory or mandatory speed limits need to be used. Table 2/1 shows design speed steps on interchange and junction elements for both the rural and urban situations as set down in **TD 22 (DMRB 6.2.1)**.

2.11 There may be situations where a major interchange is particularly complex or constrained in available area. In these circumstances it may be desirable to apply an overall speed limit to the interchange, below that which applies to the adjacent sections of the mainline. This would allow more compact elements of lower design speeds to be provided. The application of such a speed limit is a matter for discussion with the Overseeing Organisation at an early stage in the design. The complete interchange needs to be presented to drivers as an entity and would normally be the subject of uniform traffic control treatment which may require special facilities to vary it during the day.

2.12 The most efficient form of interchange layout is that which presents drivers with both the minimum number of clear unambiguous decision points and with adequate time/distance between decisions to ensure that the path through the interchange is easily understood. This means that the siting and size of advance direction signs must be appropriate for the speed and reading times involved. An acceptable interchange layout will most successfully balance the impact of the interchange on the environment with cost and the operational requirements for traffic.

Design Methodology

2.13 A flow chart illustrating the design methodology is shown in Figure 2/1.

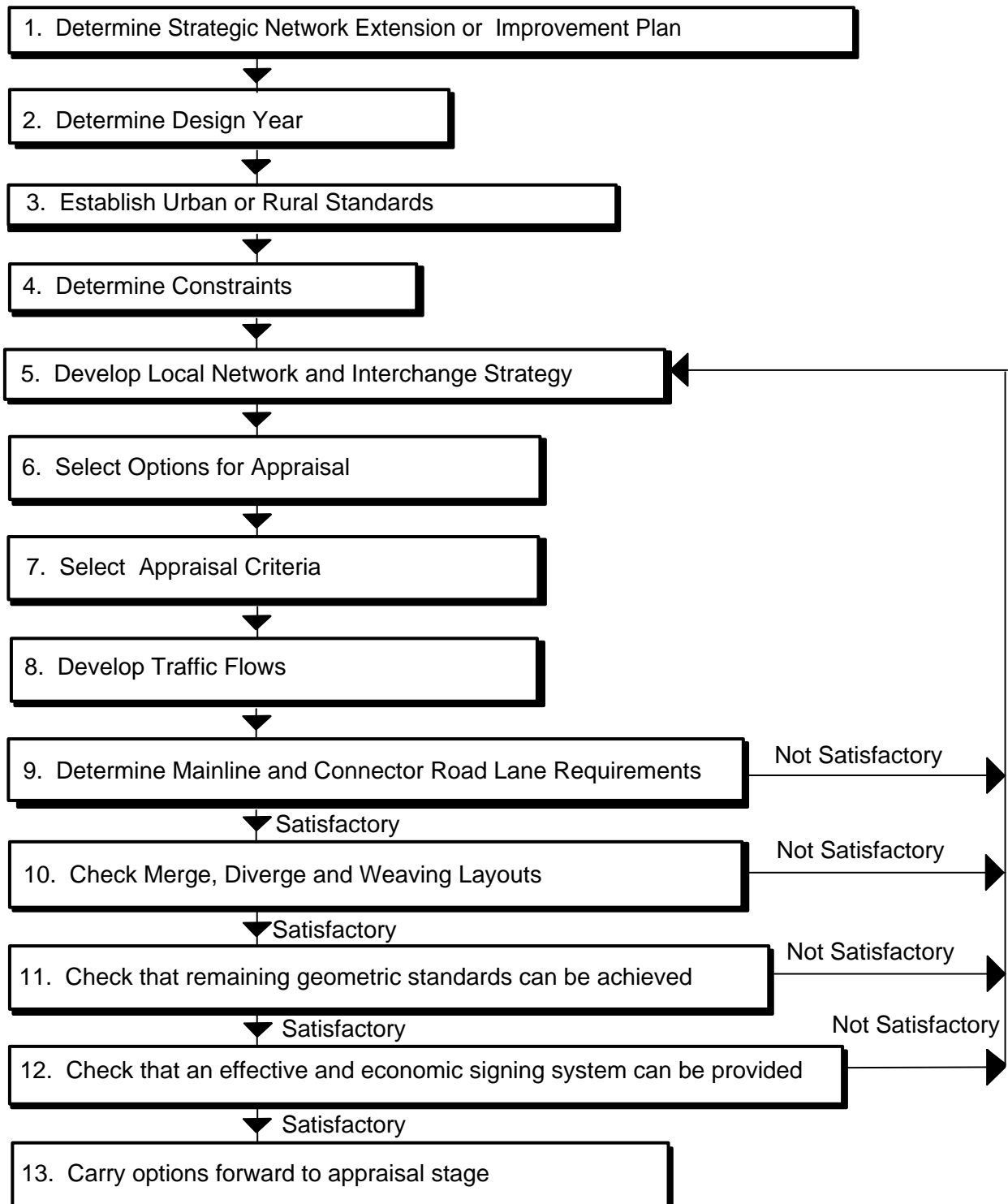

Figure 2/1 : Design Methodology

Determine Strategic Network or Improvement Plan

2.14 It is important that interchanges and lengths of motorway between interchanges are considered together from the outset. Choice of mainline carriageway provision involving wide carriageways and/or motorway link roads will influence interchange layouts. Conversely problems in achieving adequate interchange designs including merge, diverge and weaving areas may influence the choice of mainline provision.

Determine Design Year

2.15 Careful consideration of the design year will be required, bearing in mind the design year strategy adopted for the routes connected by the interchange. It will often be easier to add capacity to a motorway route than to reconstruct a major interchange and therefore high possible design year traffic flows should be adequately covered.

Establish Urban or Rural Standards

2.16 Major interchanges will normally be located on inter-urban routes designed to rural standards. However restricted space available around existing interchanges may require consideration of speed restrictions and possibly lower urban design standards, especially in peri-urban areas. A clear and definite change between rural and urban standards will be required so that drivers are made aware of the changed driving environment. This can be made by the introduction of a posted speed limit either for the whole complex or for those elements linking directly to the local urban network.

Determine Constraints

2.17 Choice of location for major interchanges on existing routes will be limited, compared with new routes. In many instances development, attracted by easy access to the motorway system, may have extended up to the existing highway boundary.

Constraints may include the following:

Environmental Constraints:

- Land take
- Effect on property
- Effect on landscape
- Effect on ecology
- Effect on rights of way
- Effect on heritage
- Noise and air quality
- Visual impact

Engineering Constraints:

- Condition of existing structures
- Topography
- Geology
- Existing traffic flows
- Existing interchange layout
- Ability to manage traffic during construction
- Ability to manage traffic during maintenance.

Develop Local Network and Interchange Strategy

2.18 This stage follows initial consideration of the broad network strategy and constraints. It will include assessment of the need to maintain provision for all existing traffic movements at the interchange or the redirection of traffic to adjacent junctions or interchanges via motorway link roads or other routes.

Select Options for Appraisal

2.19 The aim is to identify a satisfactory minimum cost solution. A comparison of at least two solutions should be made, even for relatively straightforward problems. For more complex problems several solutions should be prepared for analysis. Options should include those with minimum effect on existing traffic together with options that may cause greater disturbance during construction but would provide a potentially more efficient and/or compact layout for future use. The incremental cost of each should be compared with the quantified benefits/costs of the alternative solutions.

Select Appraisal Criteria

2.20 Appraisal criteria should be based on the factors normally considered in major scheme assessments and should include the operational assessment described in Chapter 5. It may be appropriate to apply different weighting to different criteria, depending on local factors but this should be agreed with the Overseeing Organisation. Where identified, minimum values to be achieved should be included.

Develop Traffic Flows

2.21 Derive low and high growth design year traffic flows for each section of mainline and connector road in accordance with the **Traffic Appraisal Manual (TAM)** or the **Scottish Traffic and Environmental Appraisal Manual (STEAM)** as required by the Overseeing Organisation.

Lane Requirements

2.22 Determine mainline and connector road lane requirements for each option as described in Chapter 3 of **TD 22 (DMRB 6.2.1)**.

Merge, Diverge and Weaving Requirements

2.23 Check merge, diverge and weaving layouts including lane balance. These layouts are to be provided in accordance with **TD 22 (DMRB 6.2.1)** and Chapter 5 of this design document. If the route is particularly constrained by the proximity of interchanges or by high weaving flows, controlled speed environments may need to be considered, either all day or for part of the day.

Geometric Standards

2.24 Check that remaining geometric standards specified in **TD 9 (DMRB 6.1.1)** can be achieved.

Signing

2.25 Check that an effective and economic signing system incorporating both advance direction signing and subsequent route confirmation can be provided.

2.26 Steps 9 to 12 (on Figure 2/1) may lead to the amendment or rejection of a particular option. Severe problems may lead to a reassessment of the local network strategy.

2.27 If arrangements are satisfactory they can then be carried forward to the appraisal stage.

The Appraisal Process

2.28 The development of major interchanges shall be treated in the same way as other major highway projects.

2.29 Relevant documents which shall be consulted in conjunction with the appraisal process are contained in:

TA 30(DMRB 5.1) - Choice between Options for Trunk Road Schemes.

Vol 5 DMRB - Assessment and Preparation of Road Schemes.

Vol 11 DMRB - Environmental Assessment

2.30 In many cases the scale and effect of the works required will necessitate preparation of a full environmental appraisal either for the interchange works alone or in conjunction with adjacent motorway widening or construction proposals.

2.31 The Public Consultation type framework for the comparison of several options provides a suitable basis for the assessment. This will therefore ensure that consideration is given to:

- The effects on travellers
- The effects on occupiers of property
- The effects on users of facilities
- Conservation policies
- Development and transport policies
- Costs

2.32 The effects on travellers will include an appraisal of the complexity and safety of the proposed interchange layouts. Where there are significant differences between the times and/or distances involved in negotiating the interchange, economic assessments of operating costs and time savings or delays should be carried out.

2.33 Driver stress and driver comprehension of the layout will depend on the number and timing of decisions and manoeuvres required. These will be affected by the speed of traffic and its density which may mean short gaps for manoeuvres and increased stress when weaving. This might suggest to drivers that there is an increased accident risk. Further consideration of these factors is included in the operational assessment described in Chapter 5.

2.34 Travellers will also be affected by delays during construction and the economic assessment must take account of these costs. Solutions that result in the best final arrangement may cause the greatest disturbance to traffic during construction. It is therefore important that consideration is given to the provision of temporary works as part of the designers solution. Such measures

while increasing construction costs can significantly reduce the cost of delays. It is also important that the cost of future maintenance, including traffic delay costs, is taken into account.

2.35 Safety of both motorway users and construction personnel is of prime importance in the design of major interchange improvement schemes. It is essential that designers consider the safety implications of the construction methods and traffic management measures necessary for execution of the work.

2.36 It will be necessary to establish the importance given to the feasibility of providing additional capacity at a future date for each option.

2.37 Environmental factors are likely to be very significant. There will often be limitations on the land available for new highway works and amelioration measures due to the presence of development along some parts of the motorway boundaries. The use of long lengths of elevated carriageway or the provision of additional levels over existing interchanges is likely to be environmentally intrusive.

3. GENERAL LAYOUT ADVICE

Existing Layouts

3.1 Most existing motorway to motorway connections are true interchanges providing uninterrupted movement for all turning traffic by the use of direct and semi direct interchange links and loops.

3.2 Interchanges providing the most direct links such as the 4 way 4 level diamond layout tend to be the most environmentally intrusive (see Figure 3/1(a)). Many interchanges have therefore been designed with a combination of interchange links and loops to take account of site specific constraints and traffic flows.

3.3 The 4 way 2 or 3 level cyclic layout provides a good compromise between operational and environmental considerations (see Figure 3/1(b)).

3.4 3 way interchanges may be considered as Y or T interchanges. Y interchanges are formed where two motorways approach at an acute angle and provision for movements between the acute angled legs is not included. This arrangement normally allows high speed connections between the respective motorways (see Figure 3/1(c)). Many 3 way T interchanges also provide relatively high speed interchange links, although loops are used in some cases (see Figure 3/1(d)).

3.5 Some motorway to motorway connections utilise the three level intermediate roundabout layout (see Figure 3/2(a)). While not being a true interchange in that traffic has to give way at the roundabout it has the advantage of minimising land take. As additional motorway capacity is provided, upgrading of the roundabout junctions can be particularly difficult due to restricted space. Roundabouts often provide additional connections to the local road system, which are also difficult to include in a full interchange layout.

3.6 Chapter 2 of **TA 48 (DMRB 6.2.2)** describes alternative layouts for grade separated junctions and interchanges and should be consulted for further information.

Improvement of Three Level Roundabout Junctions

3.7 Roundabouts do not provide a free flow solution for major motorway to motorway interchanges and to this extent they are a relaxation from the desirable standard. However, they can provide a

reasonable solution where interchanges are particularly constrained. Operation can be enhanced by signalisation but this is further out of character with a free flowing system.

3.8 When motorways require widening, disruption to through traffic can be minimised by adoption of layouts that put all merging and diverging at junctions on motorway link roads (see Figure 3/2(b)). For ease of maintenance link roads should be continued through the junction where possible. This will generally be easier for the low level motorway than for the high level motorway. However, regardless of traffic leaving or joining the main line or a link road, problems will continue at the roundabout due to the limited turning capacity. The capacity can be assessed by using the computer program **ARCADY/3**.

3.9 An initial solution to providing increased capacity is offered by the adoption of dedicated left turn lanes. Such provision should be either by marking or widening of the original roundabout carriageway or by the construction of a fully separate interchange link road. This will ensure that the left turn is taken at low speed or high speed and that the designers intention is clear to drivers. **TD 16 (DMRB 6.2.3)** should be consulted for advice on the provision of segregated left turn lanes at roundabouts.

3.10 Enhanced right turn capacity can be provided by the addition of one or more dedicated interchange links.

3.11 Illustrative examples of possible layouts for enhancement of junction capacity up to conversion to full free flow links are given in Chapter 6.

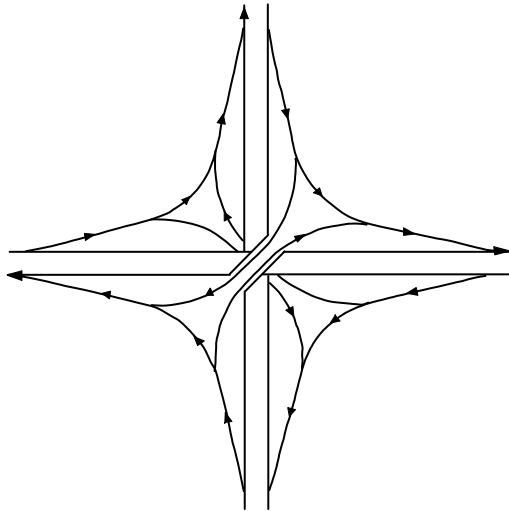

(a) 4 Way 4 Level Diamond Layout

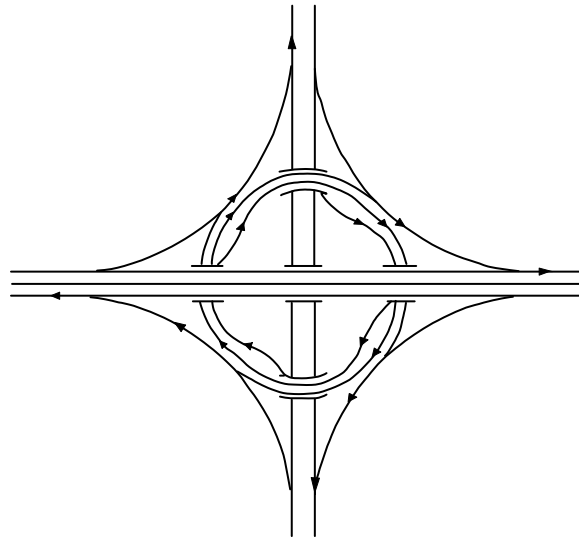

(b) 4 Way 2 Level Cyclic Layout

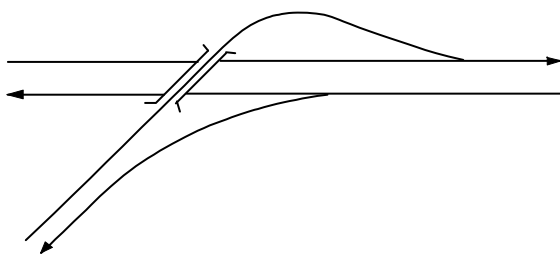

(c) 3 Way Free Flow 'Y' Layout

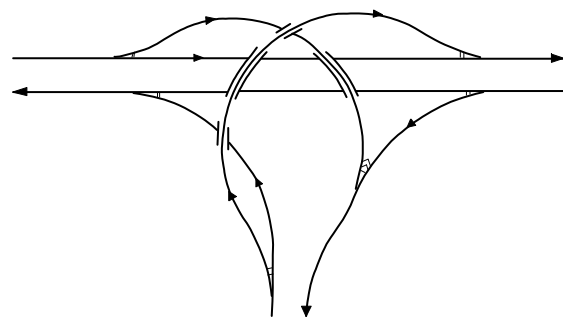

(d) 3 Way Free Flow 'T' Layout

Figure 3/1 : Major Interchange Layouts

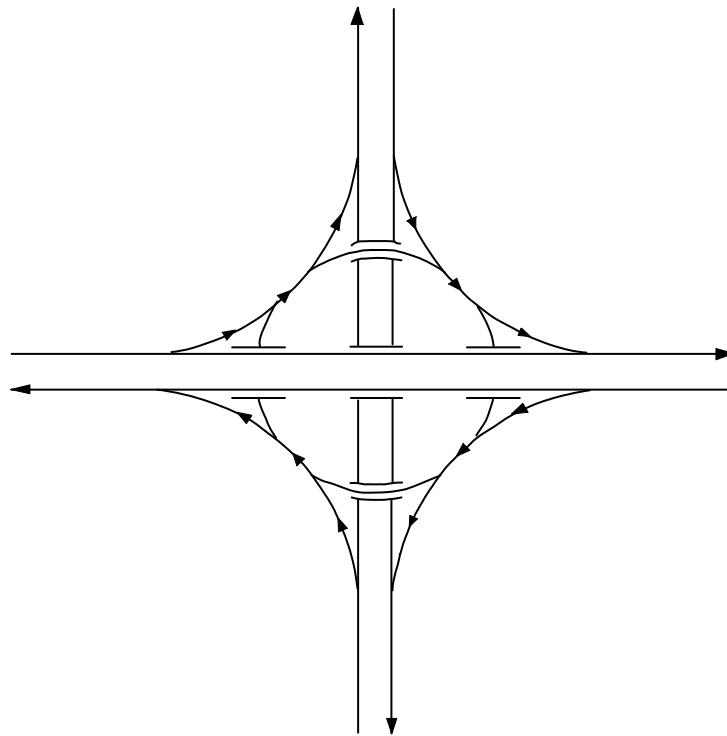

(a) 3 Level Roundabout

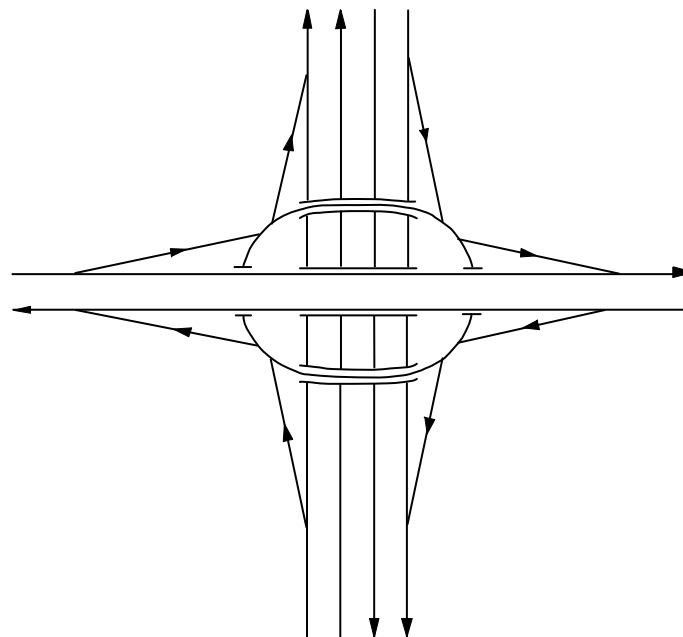

(b) 3 Level Roundabout with Link Roads

Figure 3/2 : 3 Level Roundabout Interchange Layouts

Improvement of 3 Leg 'Y' Interchanges

3.12 Improvement of 3 leg 'Y' interchanges will normally be carried out in accordance with Chapter 4 of this document.

3.13 However, where motorways leading to a Y interchange require widening to dual four lanes they cannot be simply joined together due to the resulting very wide carriageway. In these situations mainline motorways with link road layouts are more likely (see Figure 3.3(a)).

3.14 One problem associated with Y interchanges and major merges and diverges generally, is the weaving, particularly of large vehicles, after the merging of two carriageways and prior to the diverge of two carriageways.

3.15 A possible solution would be the use of crossover lanes to allow all large and slow vehicles to be grouped together prior to merges and diverges (see Figures 3.3(b) and (c)).

3.16 However, they would require the use of additional structures and extensive special signing. With the increased adoption of link roads, interpretation of traffic signs for correct route finding will become more important. There is a danger that crossover lanes would complicate road layouts and confuse drivers. Their use is therefore generally not recommended but there may be situations with high volumes of Large Goods Vehicles where such designs should be included among the options to be considered.

Improvement of Major 3 and 4 Leg Interchanges

3.17 Many existing 3 leg 'T' and 4 leg major interchanges have been designed with two lane interchange links which were necessitated by their length and gradient rather than traffic flow (para. 4.3 TD 22 (DMRB 6.2.1)). This provision has proved to be fortunate as in many cases forecast turning traffic flows for schemes involving the widening of the original mainline motorways can be accommodated on the existing interchange links. It is particularly significant where they involve a large structural content, as it would be difficult to widen or replace high level structures spanning existing motorway carriageways.

3.18 This illustrates the benefit of building in capacity for future requirements, if it can be economically justified, in situations where adding such capacity at a later date would be very difficult. Additional capacity may be required where two

interchange links join prior to merging with the mainline. A similar situation would exist at the diverge from the mainline prior to the splitting into separate interchange links.

3.19 These interchange links are eventually likely to require three lanes and so result in major merges and major diverges. The size of major merges and diverges is ultimately limited by the maximum acceptable width of mainline carriageway upstream and downstream of the interchange. Auxiliary lanes provided for lane balance at merges and diverges will add to the width of main carriageway at the interchange.

3.20 The need for major merges and major diverges may be avoided by:

- (i) Providing separate merges and diverges for each interchange link road and turning movement.

The separation of merges, especially if they involve lane additions, may be beneficial. However the signing of successive closely spaced diverges can be difficult with signing mostly from gantries, particularly where mainline carriageways are 4 lane.

- (ii) Connection of interchange links to motorway link roads.

This would direct traffic from one or a pair of interchange link roads onto a motorway link road. Traffic could reach the mainline motorway from the motorway link road via a subsequent motorway transfer road.

3.21 Illustrative examples of possible layouts are given in Chapter 6.

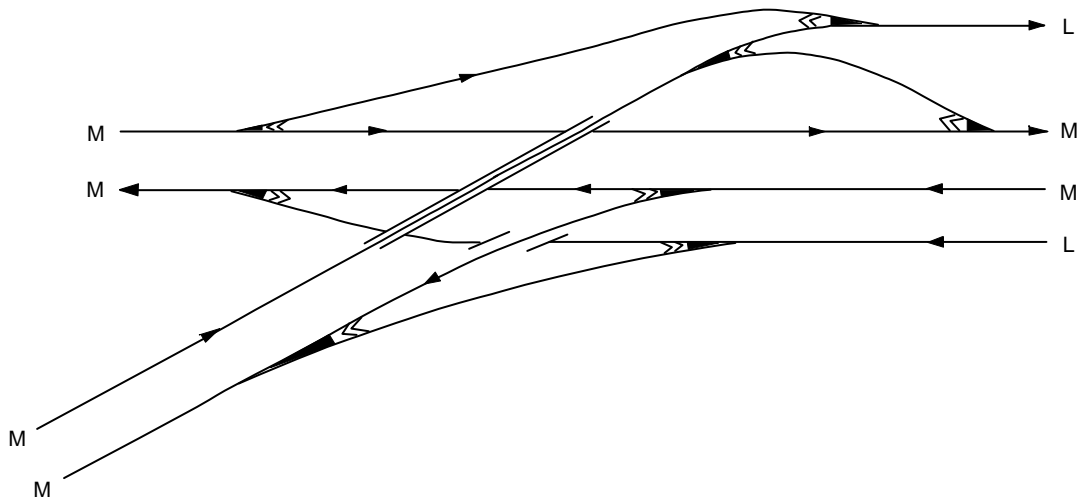

(a) 'Y' Interchange of 2 Motorways with Mainline Motorway and Link Roads

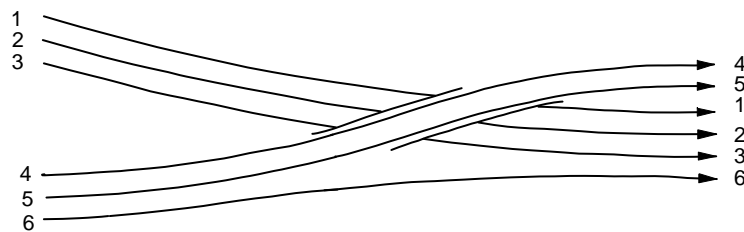

(b) 'Y' Interchange with 'Crossover' Lanes (Merge)

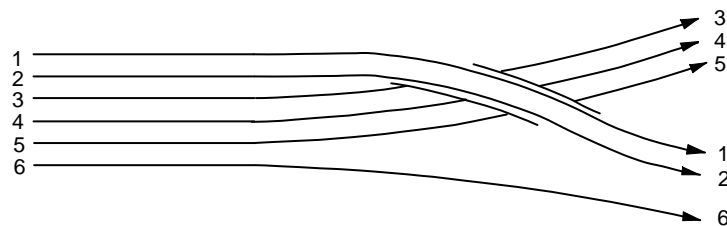

(c) 'Y' Interchange with 'Crossover' Lanes (Diverge)

Figure 3/3 : 3 Leg 'Y' Interchange

Provision for Managing Traffic in the Event of Incidents or Maintenance

3.22 In addition to the requirements of para 2.6 it is also important that all designs for major interchanges are checked for the implications of operation during incidents or planned maintenance. Adequate provision should be made for redirecting traffic and for the use of contra flow as well as making suitable provision for the quick access of emergency vehicles. This may be achieved by short links or u-turn facilities easily available to emergency vehicles.

4. MAJOR MERGES AND MAJOR DIVERGES

General

- 4.1 This chapter sets out the layout requirements for major merges and diverges where three lanes enter or exit from the mainline carriageway.
- 4.2 Consideration is given to the possible requirement for redesign of merges and diverges between interchange links where the interchange links are operating close to their two lane capacity.
- 4.3 Hourly flows, as predicted from para. 3.1 TD 22 (DMRB 6.2.1) shall be used for calculating lane provision for the merging, diverging and mainline carriageways.
- 4.4 Maximum lane capacities shall be taken as 1600 vehicles per hour for all-purpose roads and 1800 vph for motorways as specified in para. 3.2 TD 22 (DMRB 6.2.1), subject to the proviso contained therein.

General Principles

- 4.5 Lane balance should be provided for traffic merging to or diverging from the mainline. Whether traffic is joining or leaving the mainline all drivers who approach a part of the junction either from the mainline or a connector road should be able to leave that part in equivalent comfort.
- 4.6 Lane drops and lane gains will be provided at major diverges and major merges to limit the width of carriageways through the interchange. However, consideration needs to be given to additional width requirements for maintenance activities, incidents, and for future contra-flow systems during major maintenance where such provision is cost effective. This can be assessed using the computer program QUADRO. It should be made clear to drivers where lane drops and lane gains occur by the consistent use of signs and road markings.

- 4.7 The minimum spacing between the tips of the noses of successive merges, successive diverges or a diverge followed by a merge shall be $3.75V$ m, where V is the design speed in kph for the mainline, but may be increased to the minimum requirements for effective signing and motorway signalling.

Major Merges - General Principles

- 4.8 The nearside lane (lane 1) of the left-hand joining carriageway should always be provided with a lane gain. Lane gain warning signs will indicate to drivers the pattern of the junction ahead. These signs are large and their siting will need to be considered from the outset.
- 4.9 The individual merging area, within a merge, for each joining lane not provided with a lane gain, should be separated from other merging traffic and there should be space between them for mainline traffic to adjust.
- 4.10 In situations where the left hand flow is greater than the mainline flow, priority should still be given to mainline traffic and the junction set out so that traffic entering from the left gives way except where lane gains are provided.

Designing Major Merges

4.11 Major merges where three merging lanes join with a three lane mainline should be set out as Layout (a), Figure 4/1. This provides a balanced merge layout incorporating a ghost island taper merge for the faster, more manoeuvrable vehicles travelling in lane 3 and lane gains for the other two merging lanes. This is seen to be a safe option. The layout will also appear to drivers to be similar to existing TD 22 (DMRB 6.2.1) merge layouts. Large Goods Vehicles travelling in lane 1 of the mainline prior to the merge will only have to move one lane to the left to attain a normal Large Goods Vehicle carriageway position on a five lane carriageway.

4.12 Where the mainline traffic flow is light with a low proportion of Large Goods Vehicles and the merging left-hand flow is near capacity; there is scope for the dropping of the offside lane of the mainline and providing lane gains for all the merging lanes. This layout provides increased merging capacity for the left hand carriageway while also maintaining through route continuity for the mainline. The mainline offside lane should be maintained at full width for $3.75V$ m beyond the nose, where V is the design speed in kph, and then reduced in accordance with Drawing No. D6 of the Highway Construction Details (MCHW3). This is illustrated as Layout (b), Figure 4/1.

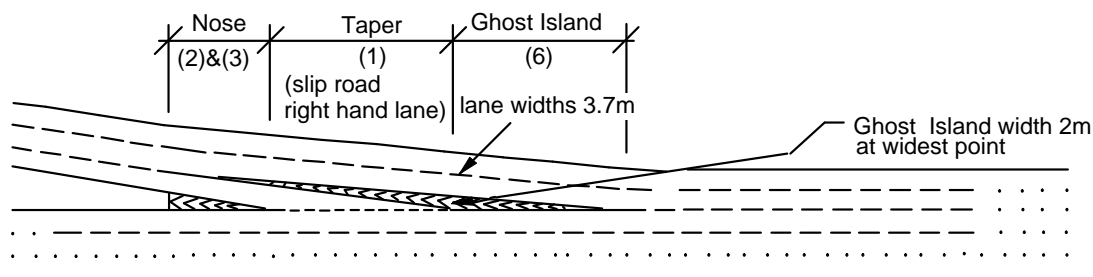

(a) Mainline Double Lane Gain at Ghost Island Merge Layout

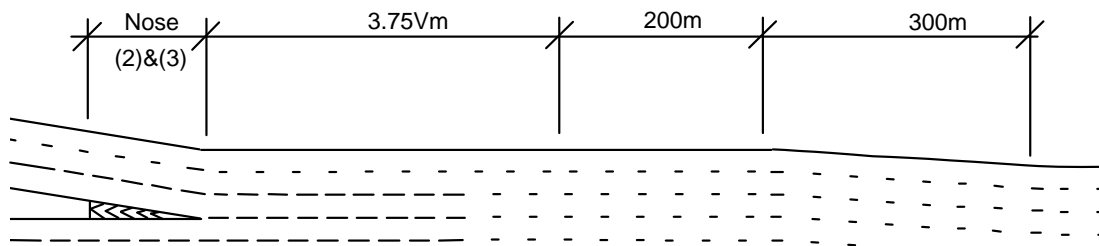

(b) Offside Lane Drop

Notes:- V is the design speed in kph.

All offside lanes are reduced according to Drawing D6 in MCHW3

Figure 4/1: Major Merge Layouts

N.B. Figures in brackets refer to columns in Table 4/4 TD 22 (DMRB 6.2.1)

4.13 There may also be extreme situations where only four lanes can be provided downstream of a major merge. Indeed there are existing examples of 3 leg 'Y' interchanges where 3 lanes join a 3 lane mainline with only three lanes provided downstream of the merge. As traffic flows increase on the joining carriageways, additional capacity will be required downstream of the merge. Where it is only possible to provide four lanes downstream of the merge, this may be achieved by reducing from 5 lanes to 4 lanes 450m (3.75 Vm for 120 kph design speed) downstream of Layout (a), Figure 4/1, in a similar fashion to Layout (b), Figure 4/1 or by the use of Layout (a), Figure 4/2.

Lane balance as set out in para. 2.12 TD 22 (DMRB 6.2.1) is not achieved with this layout and it should only be used as a last resort.

4.14 Alternatively, where the merging flow is lower but a 3 lane carriageway has been provided for reasons of continuity, the fast lane (lane 3) on the left-hand carriageway could be "hatched-out" and a two lane merge layout designed to TD 22 (DMRB 6.2.1) provided. This is shown as Layout (b), Figure 4/2.

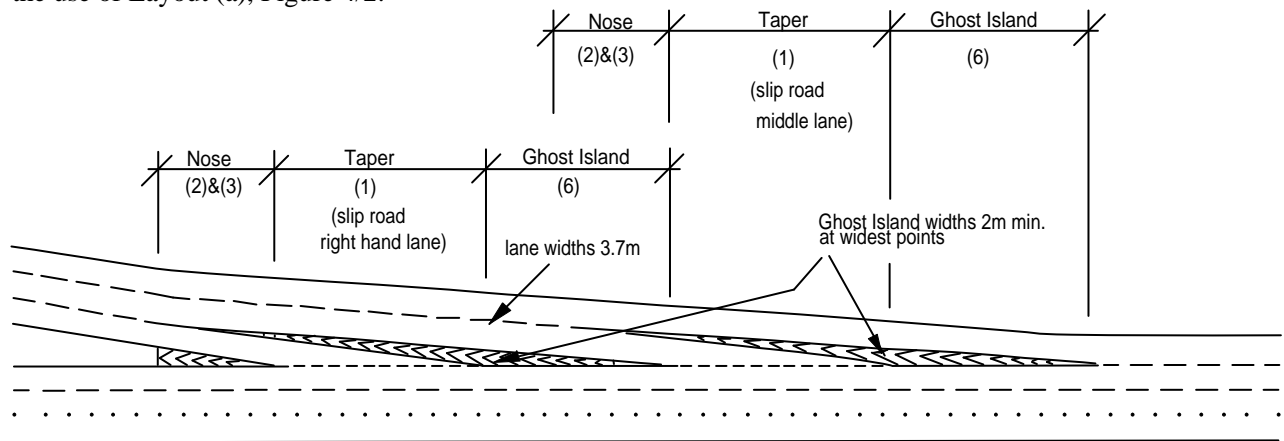

(a) Mainline Lane Gain at Double Ghost Island Merge Layout

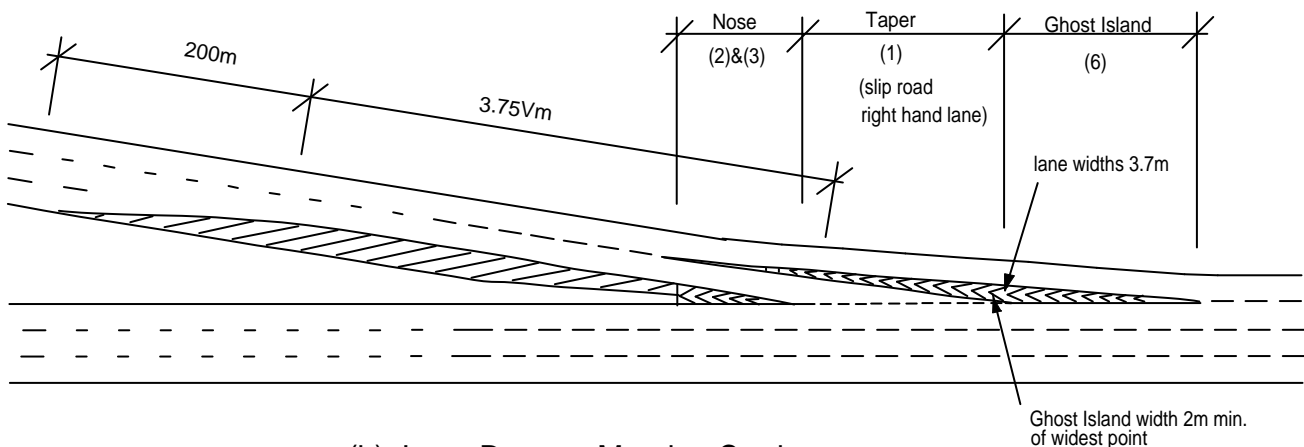

(b) Lane Drop on Merging Carriageway

Figure 4/2: Alternative Major Merge Layouts

N.B. Figures in brackets refer to columns in Table 4/4 TD 22 (DMRB 6.2.1)

4.15 Where the traffic flows on each carriageway are balanced, consideration can be given to "hatching out" one lane on each carriageway and providing a double lane gain for the left-hand carriageway as shown in Figure 4/3. This would remove the need for traffic to make all adjustments at the merge and thus provide a more balanced layout, ensuring that there is adequate provision for traffic merging from the left-hand carriageway. Adequate distance to allow traffic to adjust is required between the dropping of the lane and the merge which should be undertaken in accordance with Drawing No. D6 of the **Highway Construction Details (MCHW3)**.

4.16 Resulting from the increased capacity now being provided on mainlines a corresponding increase in the turning flows at major interchanges will occur, such that two-lane interchange links may approach their design capacity in some cases. Hence, the existing practice of providing two lanes downstream of the merge of two, 2-lane interchange links will be inadequate. Where interchange links do approach their design capacities, at least three lanes capacity will be required downstream of the merge.

4.17 This can be achieved by a number of layouts as illustrated in Figure 4/4. Which is the more suitable depends on the relative traffic loadings. The geometric parameters shown in Table 4/4 **TD 22 (DMRB 6.2.1)** are used for the

merges of interchange links and other connector roads. On urban motorways, urban standards of course apply, in which case, in the context of major urban interchanges, the ghost island length may be taken as 120m. The layouts assume that 3.75V metres is provided between the successive merge nose tips as required by para. 4.19, **TD 22 (DMRB 6.2.1)** and para. 4.7 of this design document.

4.18 In Layout (a), Figure 4/4 four lanes capacity is provided immediately downstream of the nose on the interchange link and then reduced to three lanes by the dropping of the nearside lane (lane 1) prior to the merge with the mainline. This layout provides a significant degree of flexibility to accommodate relative changes in the turning flows on the joining interchange links which may occur during the day or as a result of seasonal variations. Alternatively Layout (b), Figure 4/4 may be provided. This is a conventional **TD 22 (DMRB 6.2.1)** ghost island merge with a single lane gain. This layout may be more appropriate where there is a large percentage of Large Goods Vehicles on the left-hand interchange link and little variation in the relative turning flows on the interchange links.

4.19 There may be situations where the traffic flows on the two interchange links are unbalanced but still have a requirement for 3 lanes capacity downstream of the nose. In this case the fast lane (lane 2) of the interchange link with the lower volume should be "hatched-out" as shown in Layout (c), Figure 4/4. A lane gain is provided for the remaining lane.

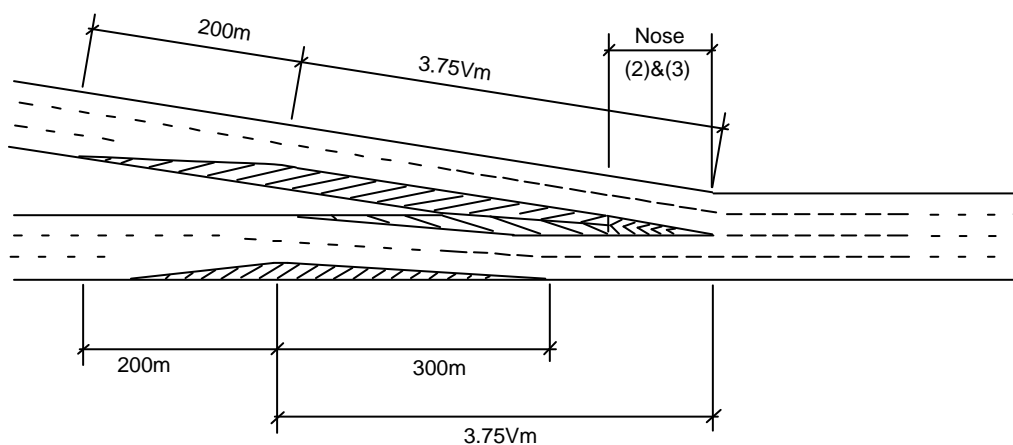

Lane Drop on Both Carriageways

Figure 4/3: Alternative Major Merge Layout
N.B. Figures in brackets refer to columns in Table 4/4 TD 22 (DMRB 6.2.1)

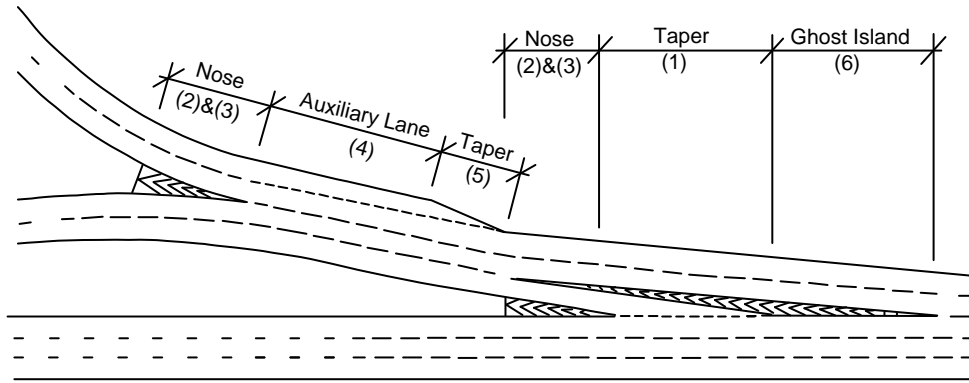

(a) Lane Drop After The Merge Nose

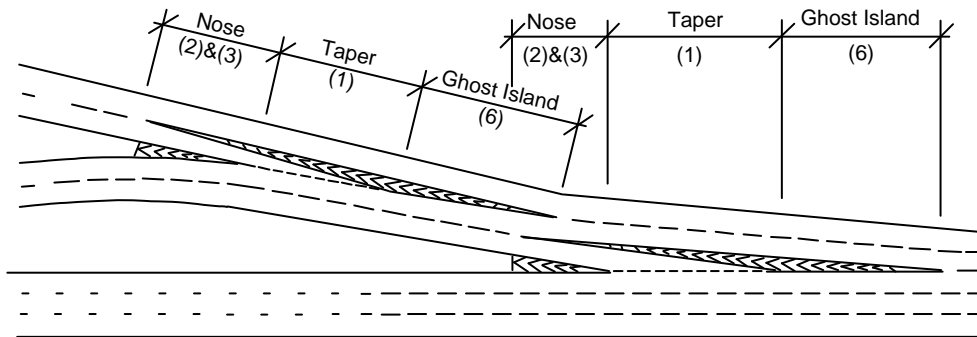

(b) TD22 (DMRB 6.2.1) Ghost Island Merge

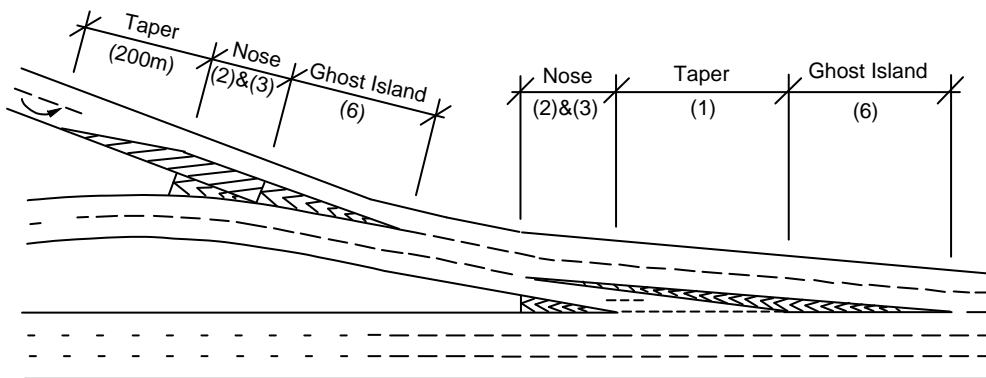

(c) Lane Drop Prior To The Merge Nose

Figure 4/4 : Merge Between Two Interchange Links

N.B. Figures in brackets refer to columns in Table 4/4 TD 22 (DMRB 6.2.1).
The layouts assume 3.75 Vm between nose tips.

Major Diverges - General Principles

4.20 Major diverge layouts should be set out so that traffic wishing to leave the mainline may do so as easily and quickly as possible. The intention is to create the diverging route alongside and allow sufficient time for the full volume of manoeuvres required for drivers crossing over and taking up positions in the diverging lanes, to take place. Traffic travelling straight ahead should therefore be inhibited as little as possible. It will be very important for drivers to be able to identify the lane they require from the overhead gantry signs early on as they approach the diverge.

4.21 At major diverges where it is anticipated that the connector road and the mainline will frequently be carrying traffic flows approaching their design capacities, prolonged opportunity to leave the mainline should be given by the provision of extended auxiliary lanes as recommended in para. 4.17 **TD 22 (DMRB 6.2.1)**.

4.25 It is preferable that diverges for left and right turning traffic at interchanges be combined so that all turning traffic leaves the mainline at one point and then makes a subsequent decision to go left or right. This is discussed further in Chapter 5. There may be rare occasions when it may be desirable to consider separating the diverges on the mainline but this is not normally recommended.

Designing Major Diverges

4.22 Major diverges where three diverging lanes leave a five lane mainline should be set out as Layout (a), Figure 4/5. This provides a balanced layout for drivers wishing either to continue on the mainline or leave on the diverging route.

4.23 Where only four lanes of capacity is provided upstream of the major diverge, Layout (b), Figure 4/5 may be used. This layout provides a degree of flexibility but where the proportion of the mainline flow leaving the through route fluctuates widely, a single auxiliary lane could be extended upstream of the start of the diverge taper.

4.24 In situations where two-lane interchange link flows approach their design capacity there will be a requirement to provide an additional lane on the interchange link, resulting in a four-lane width prior to the diverge into two separate two-lane interchange links. This auxiliary lane should be generated according to Layout (c), Figure 4/5. The geometric parameters shown in Table 4/5 **TD 22 (DMRB 6.2.1)** are used for the diverges of interchange links and other connector roads. On urban motorways, urban standards of course apply. The layout assumes that 3.75V metres is provided between the successive diverge nose tips as required by Para. 4.19, **TD 22 (DMRB 6.2.1)** and Para. 4.7 of this design document.

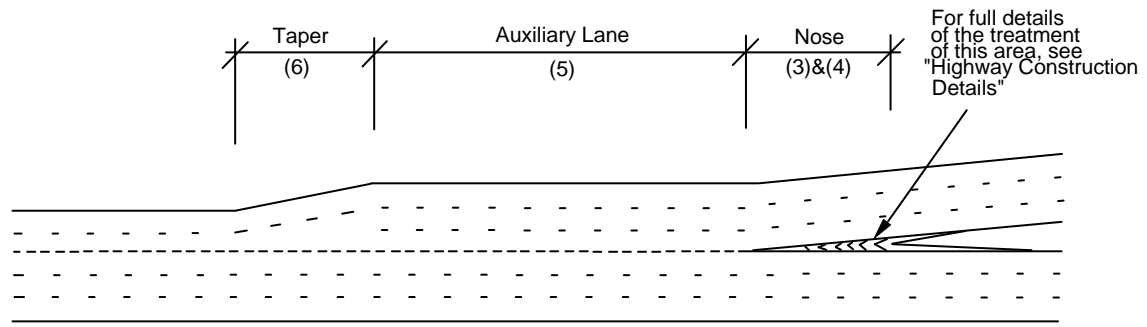

(a) Mainline Double Lane Drop at Parallel Major Diverge

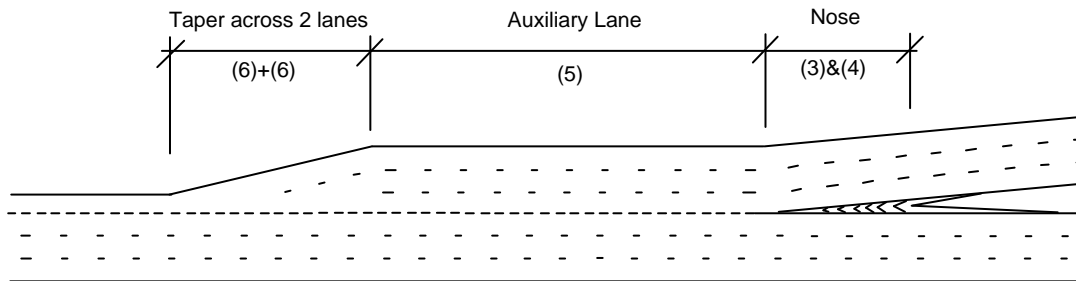

(b) Mainline Lane Drop at Parallel Major Diverge

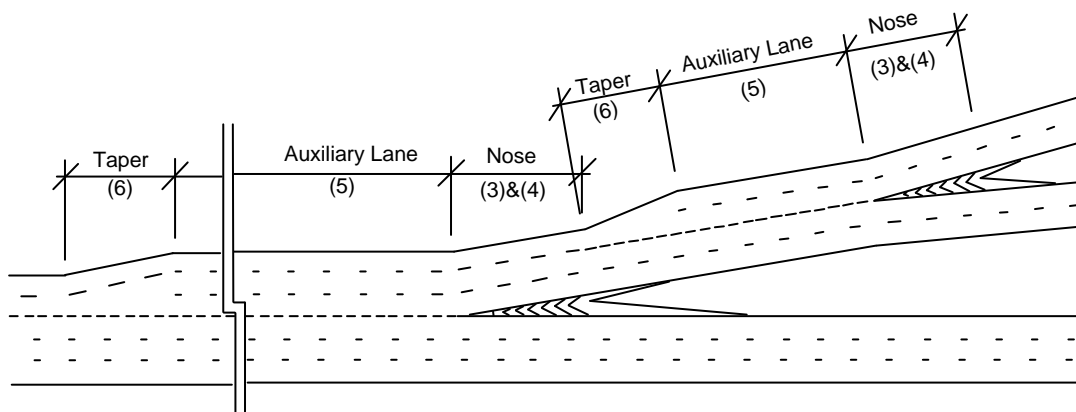

(c) Diverge Between Two Interchange Links

Figure 4/5 : Major Diverge Layouts

N.B. Figures in brackets refer to columns in Table 4/5 TD 22 (DMRB 6.2.1).
The layouts assume 3.75 Vm between nose tips

5. OPERATIONAL ASSESSMENT

General

5.1 The operational assessment is a criterion, among many others, which shall be included in the appraisal process in Chapter 2. The concept of a driver decision point and manoeuvre analysis is useful in assessing the complexity of an interchange and provides useful information on the operational aspects of different interchange layouts. This aids the determination of the most appropriate layout for individual situations. Taking into account the Driveability Appraisal (para. 5.18) also indicates layout characteristics regarding driver stress and comfort.

5.2 Decision points are required in all situations where motorists are presented with a choice of route directions and a corresponding manoeuvre may result where it is necessary to achieve the selected route. Manoeuvres can also occur in the absence of decision points such as at merges and entrances to roundabouts.

5.3 In general the most desirable interchange layout will be that option which has the minimum number of decisions and manoeuvres. Also it is desirable that decisions and manoeuvres occur where they can most readily be made without causing congestion or turbulence. This is ideally on motorway link roads or interchange links rather than on the mainline but this consideration alone should not rule out completely the adoption of separate merges and diverges. The provision of a double diverge at close spacing has specific signing difficulties associated with it and may cause particular stress on drivers travelling through the interchange.

5.4 The minimum number of decision points and manoeuvres is not the only consideration however, and the alternative layouts also need to be appraised for their practical driveability and driver workload. All driving tasks which may increase driver stress and discomfort or lead to safety problems on the interchange must be listed and evaluated when comparing options.

5.5 In particular the distance between decisions and manoeuvres is important with greater distances providing more time for drivers to select their route and/or carry out the desired manoeuvre. Some decisions and manoeuvres are of greater difficulty and more important than others. These differ from driver to driver and the approach adopted is therefore to undertake a numerical analysis of the decision points and manoeuvres augmented by a driveability appraisal.

5.6 By comparing both the numerical analysis and driveability appraisal of different options the designer can determine the most appropriate interchange layout. However the need to provide for alternative links to cope with situations of incidents or maintenance must not be overlooked.

Numerical Analysis

5.7 The numerical analysis involves the assessment of the alternative interchange layouts for left-turn, right-turn and straight on decision points and manoeuvres. The decision points and manoeuvres should be indicated for each alternative on a layout drawing. This is described further in the illustrative example.

Decision Points

5.8 A decision point occurs where there is a diverge from the mainline. The motorist must decide either to diverge from the mainline or continue straight on. The decision may need to be taken in varying traffic conditions and at speeds from slow saturation speed to motorway speed.

5.9 A decision point occurs where a diverge exists on an interchange link. The decision may be taken at or near motorway speed.

5.10 A decision point exists at an exit from a roundabout. A driver must decide to take the exit or continue on the roundabout.

5.11 A merge is not considered a decision point, although the manoeuvre may require a degree of application and skill.

Manoeuvres

5.12 Manoeuvres are made by traffic merging and diverging to and from the mainline. Minor manoeuvres are also undertaken by traffic carrying through on the mainline due to disturbance in the traffic stream resulting from the merging and diverging vehicles.

5.13 Manoeuvres also occur at merges and diverges on interchange links.

5.14 A double manoeuvre is required at a roundabout, i.e. one entering manoeuvre and one exiting manoeuvre.

Traffic Flows

5.15 The decision point and manoeuvre layouts must be considered in conjunction with a traffic flow diagram which indicates the numbers of vehicles wishing to make each turning movement.

5.16 The number of vehicles making each movement is a very significant factor as a reduced provision can be acceptable for low flows whereas for turning movements with heavy flows a high standard of provision will be required.

5.17 By allocating the traffic flows to the different directions of travel, the number of decisions and manoeuvres made for each direction can be found and the total number for the interchange layout calculated. Distinguishing between decisions and manoeuvres which occur on the mainline or on the interchange links is also important as their location is a significant factor.

Driveability Appraisal

5.18 The purpose of the driveability appraisal is to allow the consideration of factors which influence interchange operational characteristics and driver comfort but which cannot be readily incorporated in a numerical analysis of the interchange.

5.19 A totally numerical analysis might not cover the practical driveability of a layout and any driver behaviour difficulties which may impede the operation of the interchange or lead to safety problems.

5.20 A number of factors, other than decisions and manoeuvres at merges and diverges, need to be considered in assessing the operational characteristics of a major interchange. These include:

- Weaving
- Geometric effects
- Gradient
- Degree of curvature
- Type and configuration of the merge and diverge
- The number of lanes on the mainline, on merges and on diverges
- Visibility, including at night
- Network consistency
- The proportion of Large Goods Vehicles

5.21 Consideration should be given to the time/distance where a second decision occurs after a previous one. Drivers may still be recovering from, or seeking confirmation of, the first decision. As the length between decision points shortens the intensity of the lane changing and turbulence increases as drivers attempt to access lanes appropriate to their desired exit points.

5.22 Some decisions may be relatively trivial when compared with others and therefore the designer might consider them of lesser importance i.e. continuing straight ahead on the mainline through an interchange. This still may involve examination of signs, comparison of junction or route numbers with maps or memory and may require a lane change. The driver may also be affected by lane changing undertaken by other traffic. This decision could therefore involve some stress which may not be eased until a confirmatory sign was reached and the traffic stream became less turbulent.

5.23 More complicated decisions involve a large number of factors including:

- Previous map examination
- Signing
- Road markings
- Knowledge of destination or route and junction numbers
- Pressure from other drivers
- Following the vehicle in front

These decisions involve possible high levels of stress.

5.24 When assessing the driveability of the different interchange layouts the designer should concentrate on the unfamiliar driver, new to the layout. Consideration should be given to the necessary manoeuvres to attain a destination and what cognitive difficulties and stress they may present to the unfamiliar driver. Complex interchanges with lane drops can present particular difficulties for drivers of larger, slower vehicles.

5.25 For regular drivers decisions will become more trivial as they become familiar with a pattern of travelling through the interchange and will only be concerned with planning their most beneficial manoeuvres to attain their position ahead. Therefore in situations where the percentage of familiar (i.e. commuter) drivers is high, the number of decisions becomes less important but the significance of manoeuvres remains unchanged.

5.26 Major interchanges present older drivers with particular problems. There is evidence to suggest that some older drivers may avoid the more complex interchanges due to their complicated nature. Older driver problems are reduced by increased length between decision points or slower speeds but this is generally not possible at major interchanges. Indeed other traffic may force a higher speed on older drivers thereby increasing their difficulties. In general older drivers require simple information and more time to select and respond, and this need for simplicity in design should be considered in the assessment.

5.27 Having carried out both a numerical analysis of the decision points and manoeuvres as well as a driveability analysis of the alternatives, the designer has obtained considerable useful information to aid the selection of the most appropriate alternative. Also areas where the selected alternative can be altered to provide an improved interchange for drivers may have been identified.

Illustrative Example

5.28 In order to illustrate the operational assessment procedure an example comparing two four-leg interchange layouts is presented. The two alternatives which are considered are a single exit/single entry diamond layout and a double exit/double entry cyclic layout.

Example of Numerical Assessment

5.29 The two alternatives are shown in Figure 5/1 and the decision points and manoeuvres appropriate to each are identified. Sample traffic flow figures have been assumed as shown in Figure 5/1(a).

5.30 Consider traffic travelling from south to east through the interchanges. For the single exit/single entry layout, drivers must decide to depart from the mainline and then make a decision to go right at the diverge on the interchange link. They also have to make manoeuvres at these points, as well as at the merge of the interchange links and the merge with the mainline. These decisions and manoeuvres are divided into those which occur on the mainline or on interchange links and multiplied by the appropriate traffic flow from the traffic flow diagram. Likewise this can be repeated for the other movements through the interchange and the totals for the interchange calculated. It should be noted that drivers continuing straight through the interchange must make a decision to do so at diverges and a manoeuvre is also allocated at merges and diverges to allow for the disturbance of mainline traffic due to the merging and diverging traffic.

5.31 For the same movement through the double exit/double entry interchange, drivers must decide to continue straight ahead at the first diverge and then make another decision to depart at the second diverge. Likewise manoeuvres are made at these points and also where the driver merges with the mainline and at the second merge due to the disturbance caused by merging traffic.

5.32 The results of the numerical assessment for both alternatives are presented in Table 5/1.

| Alternative | Item | Mainline | Inter-change | Total |
|------------------------------|------------|----------|--------------|--------|
| Single exit/ Single entry | Decisions | 33570 | 13012 | 48582 |
| | Manoeuvres | 67140 | 26024 | 93164 |
| Double exit/ Double entry | Decisions | 60634 | 0 | 60634 |
| | Manoeuvres | 121268 | 0 | 121268 |

5.33 From Table 5/1 it can readily be seen that the double exit/double entry layout requires approximately 30% more decisions and manoeuvres than the single exit/single entry option. Also all the decisions and manoeuvres occur on the mainline for the double exit/double entry alternative. For the single exit/single entry alternative, approximately 70% of decisions and manoeuvres take place on the mainline with the remainder on the interchange links.

Example of Driveability Assessment

5.34 The assessment of the topics in para 5.20 which can be made on the driveability of either layout in this illustrative example is less than would be possible in a real situation as many of the factors relating to driveability are scheme dependent rather than dependent on the layout type.

5.35 The assessment can be presented as a descriptive analysis of the driveability of the interchange as this will allow the designer scope to consider all factors relevant to a particular layout, as well as those points raised in this design document.

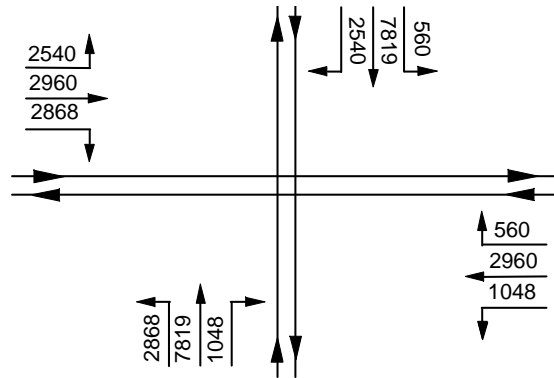

(a) Traffic Flow Diagram

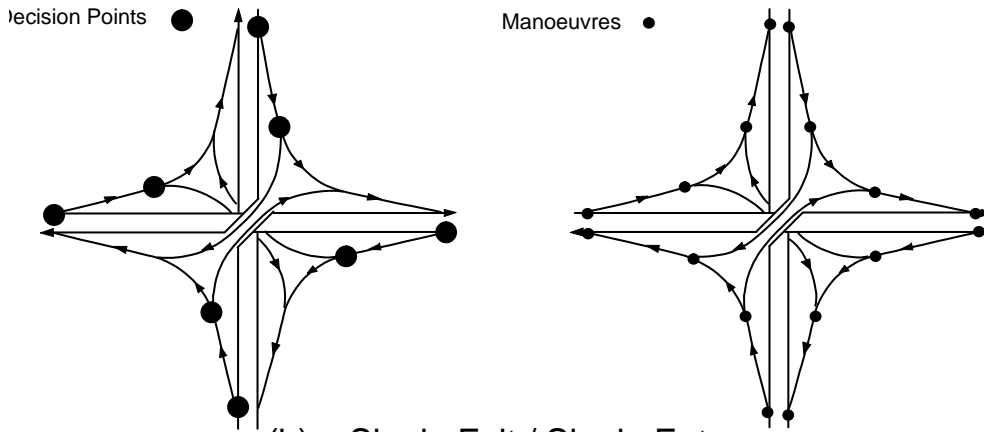

(b) Single Exit / Single Entry

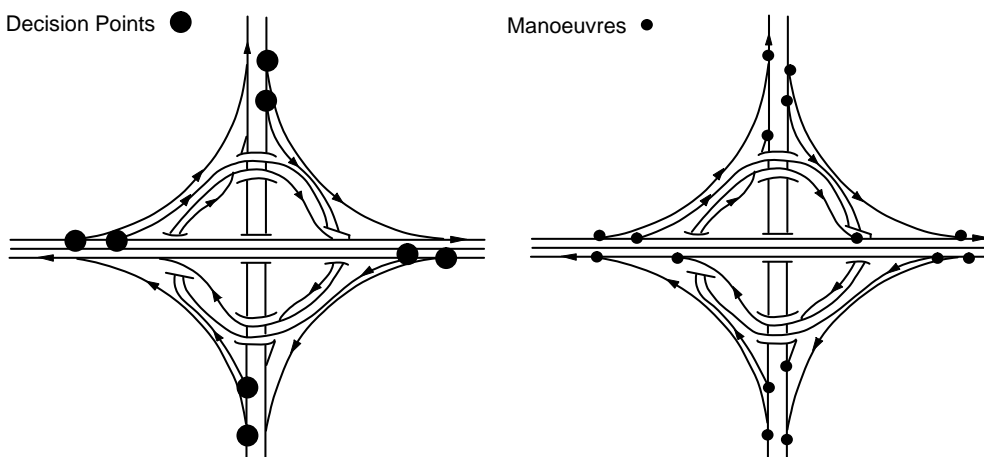

(c) Double Exit / Double Entry

Figure 5/1 : Decision Point/Manoeuvres Alternative Layouts

Single Exit/Single Entry Layout

5.36 The single exit/single entry interchange layout is consistent with the majority of the motorway network and therefore will be very familiar to drivers. Also the signing of one exit to one other route presents drivers with an uncomplicated choice between routes. However a second decision without significant advance signing is required quickly after the driver has decided to depart from the mainline.

The layout of a major parallel diverge, likely at single exits, is easier to access than more minor diverges. However the large number of vehicles exiting at these diverges is likely to reduce this benefit. Also large traffic numbers at merges will reduce the driveability of these elements.

Traffic travelling straight ahead at the interchange will experience the minimum of disturbance from traffic merging and diverging to and from the mainline.

The four-level single exit/single entry interchange has a high geometric standard and provides drivers making turning movements with an easy route to steer through the interchange.

Layouts with only one exit and entry provide the maximum length available for weaving on the mainline.

Double Exit/Double Entry Layout

5.37 The double exit/double entry interchange layout is not consistent with the majority of the motorway network and is therefore less familiar to drivers. The signing of the same route number both to the left and straight ahead increases the possibility of drivers making the incorrect choice of direction. However the provision of double diverges, particularly where lanes are dropped, may lend itself to the signing to a particular destination of a specific lane, which automatically leads via a fixed path, to the required route and direction.

Reduced traffic levels on diverges and merges will improve their driveability although this may be offset by reduced provision at these locations.

Traffic travelling straight ahead at the interchange will experience greater disturbance from traffic merging and diverging to and from the mainline and this will reduce the driveability of the interchange for these drivers. A large proportion of the decision point and manoeuvre totals for this layout result from straight ahead traffic passing the diverges and merges. For a high percentage of this traffic these decisions and manoeuvres might be said to be trivial.

The two-level double exit/double entry interchange has curved alignments through the interchange and includes reverse curves on right-turn interchange links.

Layouts with double exits and entries shorten the available mainline weaving length between junctions. This makes it more difficult for drivers to attain their desired position on the approaches to junctions and also causes greater disturbance to straight through traffic.

Example Summary of Driveability Assessment

5.38 For ease of presentation and comparison of the driveability assessments of alternative layouts the descriptive analysis can be summarised in a table and a rating allocated to each alternative for the factors identified. The marking system ranges from 0, for a very good standard, to 5 for a very poor standard. The alternative with the lowest total represents the best layout with regard to driveability. The summary and comparison table for the example is shown on Table 5/2.

5.39 In this illustrative example the single exit/single entry four-level interchange has the lowest number of decisions and manoeuvres as well as the best driveability assessment. It therefore represents the more desirable layout from an operational aspect. The choice of option must however take into consideration the environmental impact assessment and incremental cost analysis.

| | Single Exit/ Single Entry | Double Exit/ Double Entry |
|---------------------|------------------------------|------------------------------|
| Route Finding | 1 | 2 |
| Merges | 2 | 1 |
| Diverges | 1 | 2 |
| Curvature | 1 | 3 |
| Geometry | 2 | 2 |
| Weaving | 1 | 2 |
| No of Lanes | 2 | 1 |
| Network Consistency | 0 | 2 |
| Totals | 10 | 15 |

Table 5/2: Summary and Comparison of

Alternative Driveability Appraisal Framework

5.40 Alternatively the descriptive analysis could be omitted and a more extensive framework, including a better defined valuation system, could be adopted. This framework assesses each direction through the interchange under a series of factors and a ranking is allocated according to the standard provided.

5.41 The ranking system ranges from 0 (very good) to 5 (very poor) as before but is better defined. For example, in the case of interchange links, covering radii and sight distance etc, the ranking system is defined as:

- 0 - very good
- 1 - good
- 2 - desirable minimum
- 3 - one design speed step below desirable
- 4 - two design speed steps below desirable
- 5 - departures involved

For merges/diverges the ranking system is defined as:

- 0 - none
- 1 - lane drop or lane gain
- 2 - simple merge/diverge
- 3 - ghost island or 2 lane exit
- 4 - congested entry/exit with parallel auxiliary lanes
- 5 - long auxiliary lanes

5.42 The total ranking for each direction is multiplied by the traffic flow for the movement. This weights the appraisal for movements with heavier flows as they are of more importance than movements with low flows. The minimum total indicates the most driveable option.

5.43 A typical example of a driveability appraisal framework is illustrated in Table 5/3.

| Direction | N-S | N-E |
|------------------------------------|-----------|------------|
| Movement | Through | Turning |
| Traffic Volume | Q(NS) | Q(NE) |
| Factors: | | |
| Diverges | 0 | 2 |
| Geometry of Links | 1 | 3 |
| Merges | 0 | 1 |
| Ease of Route Finding | 1 | 3 |
| Ease of Correcting Wrong Manoeuvre | 4 | 4 |
| Sub-total | 6 | 13 |
| TOTAL | 6 x Q(NS) | 13 x Q(NE) |

Table 5/3: Typical Example of Driveability Appraisal Framework

6. EXAMPLES OF UPGRADE PATHS FOR MAJOR INTERCHANGES

General

6.1 This chapter presents examples of some common interchange layouts and illustrates a range of possible improvements for consideration. Relevant highway schemes from different DOT Regional Offices were reviewed in the development of this design document and account has been taken of this research in determining possible improvements to the examples. Layouts are shown as line diagrams in order to include a reasonable number of alternatives. The examples shown are not intended to represent the complete range of solutions and other options or combination of options could be considered. Individual major interchange schemes will have to take account of their particular circumstances and constraints.

6.2 The three layouts considered for improvement are:

- (i) 3 level roundabout
- (ii) 3 leg "T" interchange
- (iii) 4 leg interchange

Improvement of 3 Level Roundabout Interchange

6.3 Varying degrees of improvement can be undertaken to 3 level roundabouts depending on the individual situation, and slightly different appraisals would be undertaken for the different levels of improvement.

6.4 One situation is where a range of possible improvements and capacity enhancements is possible with corresponding ranges of costs and environmental effects. Another is where severe constraints limit the improvements that can be made.

6.5 This will require a "value for money" comparison between the range of improvements. Appraisals for these improvements will be simpler than for more extensive alterations and mainly be concerned with the additional capacity provided, the construction costs and the environmental effects of each improvement. Where there are severe constraints a medium term solution with a design life less than usual could be adopted pending further developments to the highway network local to the interchange, when a further increase in capacity may be required. In terms of comparisons, the shorter "design life" implies that the interchange would be subjected to traffic flows in excess of its capacity for more hours in the year than other designs prepared for the normal design year.

6.6 Typical improvements include:

- (i) Dedicated left turn lanes close to the roundabout (see Figure 6/1(a)).

These lanes may be provided for largely insignificant landtake and cost while providing a significant improvement to the roundabout operation. However the improvement in the operation of the interchange will be restricted, as these dedicated lanes would use the same diverges and slip roads as traffic for other routes.

- (ii) Selected dedicated left turns on separate links where possible. Where separate links are not possible left turns on dedicated lanes are provided close to the roundabout (see Figure 6/1(a)).

The provision of separate left turn links will provide additional operational improvement compared with dedicated left turn lanes as

they will have individual diverges, merges and connector roads. They will however result in additional landtake and cost and require the minimum 3.75V m spacing between the successive merges and diverges.

- (iii) Selected new right and left turn interchange links to separate the heaviest movement from the roundabout (See Figure 6/1(b)).

The selected new right turn interchange link will result in significant cost due to the requirement for two overbridges but will have a very significant improvement on the operation of the interchange where one movement dominates. Possible sterilisation of land could occur between the right turn interchange link and the existing roundabout. Greater visual intrusion of the interchange on the surrounding area would also result from the height of the right turn connector road.

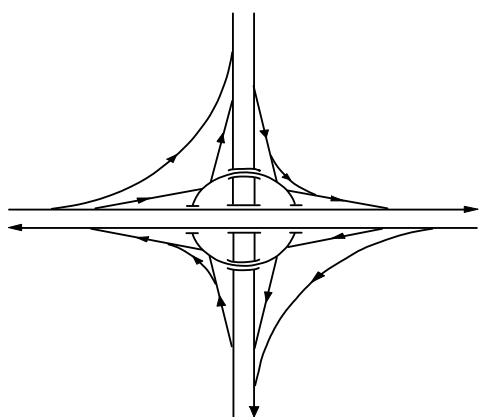

(a) Dedicated Left Turn Lanes and Selected Separate Interchange Links

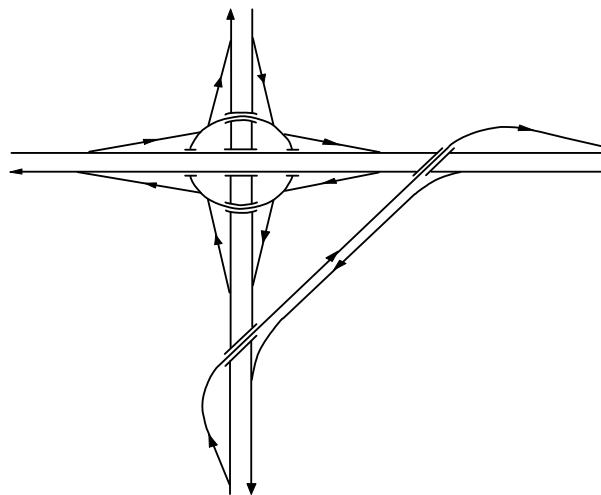

(b) Selected Right and Left Turn

Figure 6/1: Possible 3 Level Roundabout Improvements

6.7 The other situation is where two or more types of extensive improvements are possible. These will require a framework type appraisal as indicated in Chapter 2 - Design Procedure.

6.8 The range of possible improvements include:

- (iv) Selected new right and left turn interchange links in the least intrusive quadrant(s) (see Figure 6/1(b)).
- (v) Connection of the 3 most heavily trafficked legs with free flow semi-direct interchange links (see Figure 6/2(a)).
- (vi) Connection of the 3 most heavily trafficked legs with free flow cyclic interchange links (see Figure 6/2(b)).

6.9 Layouts (v) and (vi) have advantages where one leg of the original junction has lower traffic flows than the other three legs. The original roundabout is retained to provide turning movements to and from the less busy leg. It can also maintain additional connections from the original junction and provide U turn facilities for maintenance vehicles.

6.10 Layout (vi) is likely to provide a more compact interchange layout but with additional structural content. Also where space allows, consideration can be given to providing the remaining set of cyclic interchange links at a later date, completely replacing the roundabout with a free flow interchange.

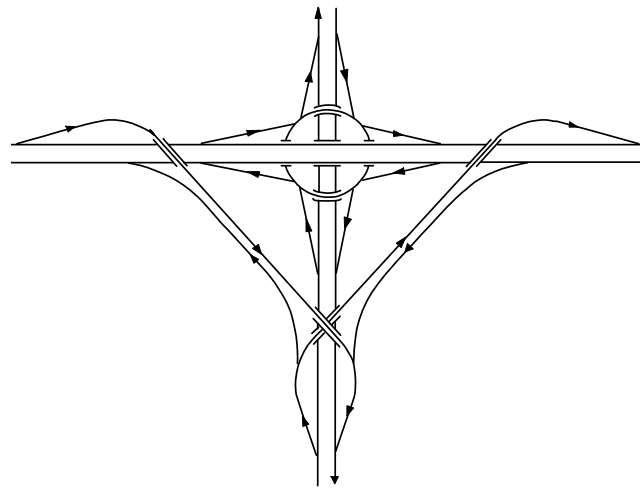

a) Connection with Semi-direct Interchange Links

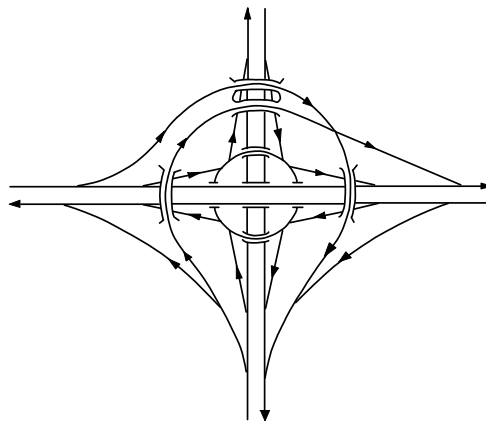

(b) Connection with Cyclic Interchange Links

Figure 6/2: 3 Level Roundabout connections between Three Legs with Free Flow Interchange Links

Improvement of Three Leg "T" Interchange

6.11 A typical motorway "T" interchange with legs A, B and C and conventional left side merges and diverges is shown in Figure 6/3(a). The major route is considered to be A-B although the layout can be orientated so that any movement has priority. They are less complicated than four leg interchanges and, except on loops, traffic can expect to travel through the interchange at relatively high speed.

6.12 On existing dual three lane motorways it would be normal to introduce two lane diverges with a lane drop so that all interchange links were two lanes wide. If necessary three through lanes could be maintained on the major route and all merges and diverges can be designed in accordance with TD 22 (DMRB 6.2.1).

6.13 Widening of the mainline motorways to dual four lanes would not greatly change the situation as the approaching mainlines could simply diverge into individual two lane interchange links.

6.14 However, widening of the mainlines to dual 5 lanes would require some interchange links to be at least three lanes wide, introducing the need for major merges and diverges.

6.15 Figure 6/3(b) shows a basic layout designed with major merges and diverges. This allows interchange links to be direct, rather than semi direct. However, depending on construction and traffic management problems it may be necessary to retain existing semi direct link layouts even when existing merge and diverge areas are improved and interchange links widened.

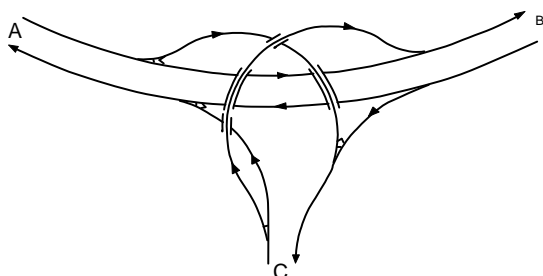

(a) Typical layout with Semi-direct Interchange Links

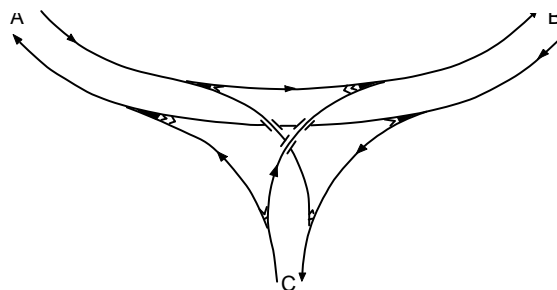

(b) Major Merge/Diverge Layout with Direct Links

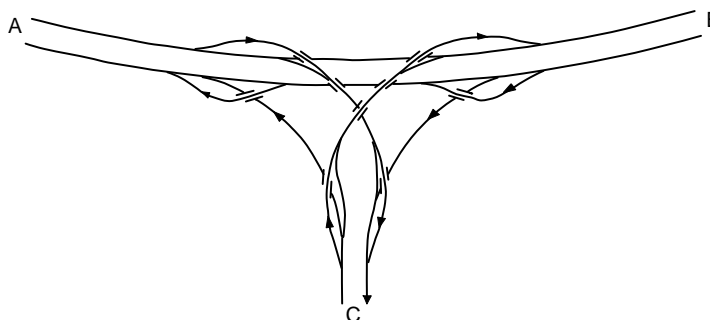

(c) Interchange with Large Goods Vehicle Crossover Lanes

Figure 6/3: 3 Leg 'T' Interchange Layouts

6.16 Figure 6/3(c) shows the possible addition of crossover lanes which reduce the problems associated with Large Goods Vehicles and other slow moving vehicles at major merges and diverges. Crossover lanes are generally considered undesirable because of problems associated with signing two routes for the same destination and also as the additional structures will cause greater environmental intrusion, landtake and cost. However the provision of crossover lanes may be appropriate on motorways with high volumes of Large Goods Vehicles.

6.17 Figure 6/4(a) shows an alternative layout using motorway link roads. Left turn movements are made from the link roads and right turn movements made from the original mainlines. Movements between the mainline and link roads take place via transfer roads at appropriate distances from the main interchange. The length of

carriageway shown hatched would be retained for maintenance purposes. This layout eliminates problems with major merges and diverges although satisfactory designs must be provided for the mainline/link road transfer roads. Signing would need to be clearly associated with the relevant carriageway and this might involve complex gantries. The use of direct interchange links allows the adoption of a design speed through the interchange which is close to that of the rest of the route.

6.18 Figure 6/4(b) shows a variation where turning movements start and finish on the mainline or link road depending on the layout of the original interchange. In this layout the structures from the original interchange are retained. This approach is also of significant value at four leg interchanges where reconstruction of the original multi-level interchange structures and interchange links would be very difficult.

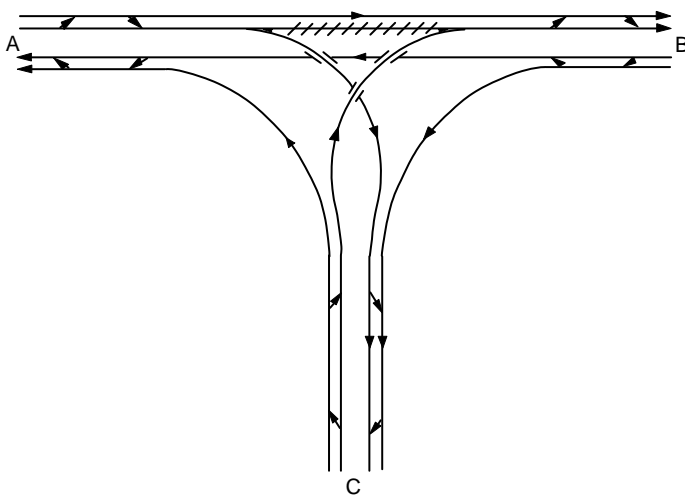

(a) Direct Interchange Links

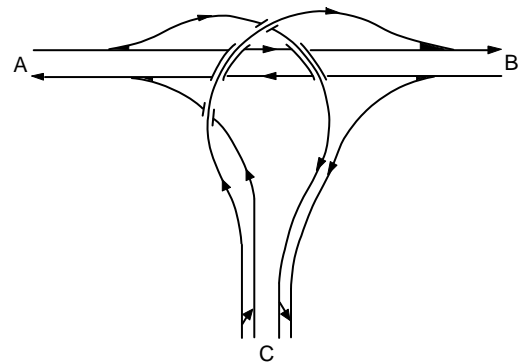

(b) Semi-direct Interchange Links

Figure 6/4 : 3 Leg 'T' Interchange Layouts with Link Roads

Improvement of Four Leg Interchange

6.19 This example relates equally to cyclic, diamond or other layouts containing existing two-lane interchange links which are generally adequate for forecast traffic flows.

6.20 The following layouts shown in Figure 6/5 indicate possible improvements which should be considered. For simplicity only one area of the interchange is being considered in details as shown on the key plan in Figure 6/5.

6.21 Expansion of existing layout leading to major merges and diverges on the mainline (Figure 6/5(a)).

This layout will ultimately be restricted by the maximum acceptable mainline width upstream and downstream of the interchange. It will probably need mainline lane drops and lane gains in order to minimise the carriageway width at the major merges and diverges.

6.22 Separate Merges and Diverges for each interchange link (Figure 6/5(b)).

Merges and diverges would remain within **TD 22 (DMRB 6.2.1)** Standards. This arrangement can be helpful with merges, especially if lane additions are provided and can reduce problems with Large Goods Vehicles having to move to the left. However it will be difficult to sign closely spaced diverges on 4 lane mainline carriageways with gantry signing. Separate merges and diverges are likely to cause more turbulence on the mainline compared with single merges/diverges.

6.23 The adoption of layouts incorporating link roads are likely where forecast traffic flows are greater than can be accommodated by a widened motorway or where the spacing between junctions is short resulting in reducing weaving provision. The selection of the most appropriate layout of interchange links will depend on mainline and turning traffic flows, traffic destinations and preferred mainline and link road carriageway widths. Link road layouts generally remove the requirement for major merges and diverges.

6.24 One Interchange link connecting to mainline and one interchange link connecting to motorway link road (Figure 6/5(c)).

This layout is appropriate where the majority of turning traffic is travelling a number of junctions downstream of the interchange and there is sufficient capacity on the mainline. Link road flows are likely to be low.

6.25 Both interchange links connected to motorway link road (Figure 6/5(d)).

The connecting of both interchange links to the link road is desirable where a large proportion of traffic travels only a few junctions along the motorway. This keeps disturbance to the mainline to a minimum. There is a possibility that three-lane link roads may result where traffic flows are high.

6.26 As previous layout but with provision for one interchange link to connect to mainline motorway and link road (Figure 6/5(e)).

This layout combines the connections provided in layout (c) and (d) where their provision results in a desirable balance between mainline and link road traffic flows.

6.27 Braiding which allows both interchange links to connect to the mainline or link road (Figure 6/5(f)).

Link road layouts incorporating braiding are appropriate where turning traffic flows are high and other solutions would result in undesirably wide link roads or congestion on the mainline. They may also be appropriate where another junction is very close to the major interchange and adequate weaving provision, required for the other solutions, cannot be provided on the link road or mainline.

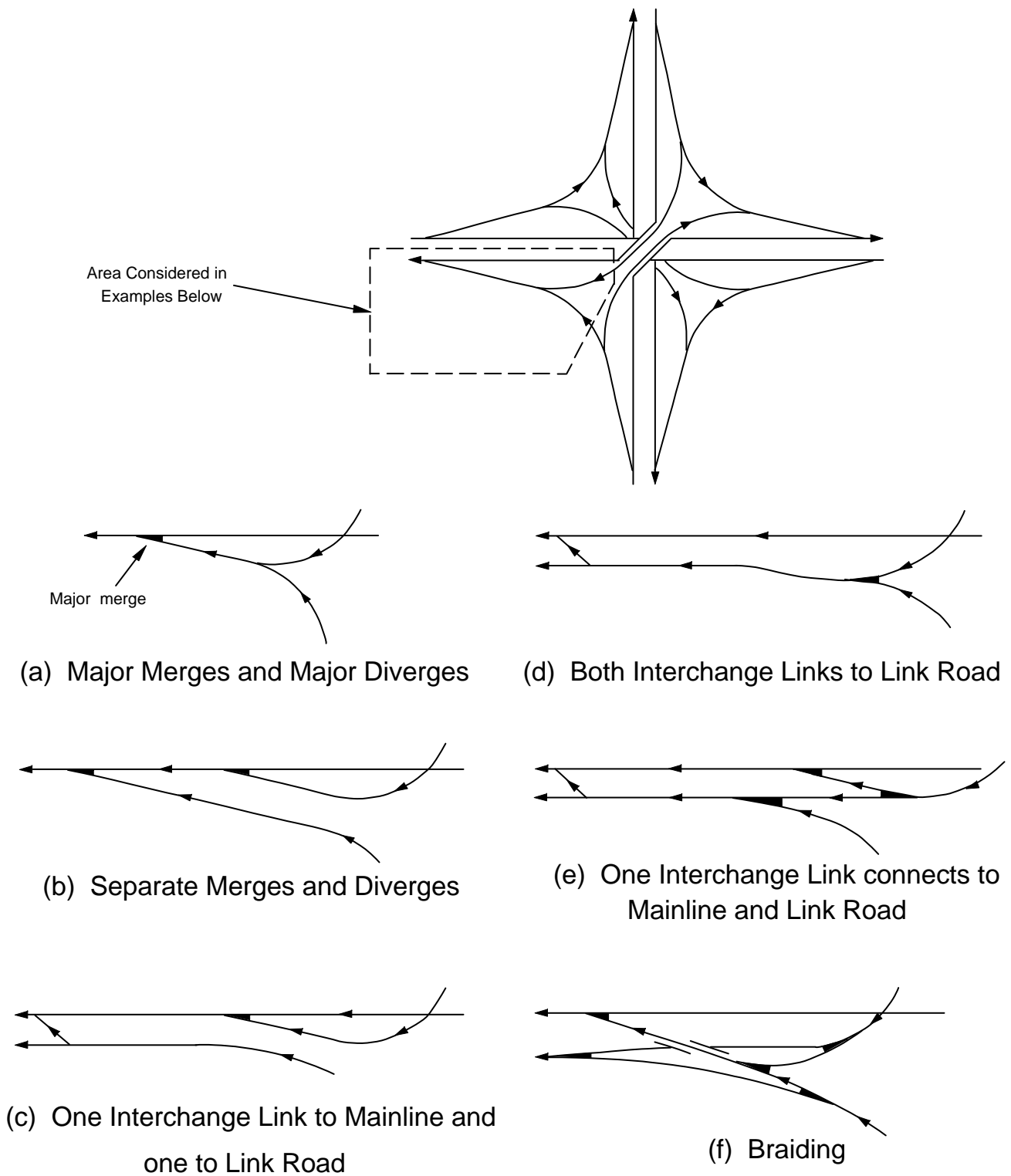

Figure 6/5 : Possible Improvements to 4 Leg Interchanges

7. REFERENCES

7Introduction

- (a) **TD 22 (DMRB 6.2.1)** - Layout of Grade Separated Junctions
- (b) **TA 48 (DMRB 6.2.2)** - Layout of Grade Separated Junctions
- (c) **BS 6100 Subsection 2.4.1** - The British Standard Glossary of Building and Civil Engineering Terms - Part 2 Civil Engineering: Section 2.4 Highway and Railway Engineering: British Standards Institution.

8Design Procedure

- (a) **TD 22 (DMRB 6.2.1)** as Chapter 1
- (b) **TA 48 (DMRB 6.2.1)** as Chapter 1
- (c) **TA 23 (DMRB 6.2)** - Determination of Size of Roundabouts and Major/Minor Junctions
- (d) **Traffic Appraisal Manual** - (TAM) 1: DoT: 1982
- (e) **Scottish Traffic and Environmental Appraisal Manual** - (STEAM) : SDD : 1986
- (f) **TD 9 (DMRB 6.1.1)** - Road Layout and Geometry : Highway Link Design
- (g) **TA 30 (DMRB 5.1)** - Choice Between Options for Trunk Road Schemes
- (h) **Vol 5 DMRB** - Assessment and Preparation of Road Schemes
- (i) **Vol 11 DMRB** - Environmental Assessment.

9General Layout Advice

- (a) **TA 48 (DMRB 6.2.2)** as Chapter 1
- (b) **TD 16 (DMRB 6.2.3)** - The Geometric Design of Roundabouts
- (c) **TD 22 (DMRB 6.2.1)** as Chapter 1

10Design Standard

- (a) **TD 22 (DMRB 6.2.1)** as Chapter 1
- (b) **QUADRO 2 Manual** : DoT: 1982
- (c) **Highway Construction Details - (MCHW3)**

6 Examples of Upgrade Paths for Major Interchanges

- (a) **TD 22 (DMRB 6.2.1)** as Chapter 1

8. ENQUIRIES

All technical enquiries or comments on this document should be sent in writing as appropriate to:-

The Civil Engineering and
Environmental Policy Director
Highways Agency
St Christopher House
Southwark Street
London SE1 0TE

T A ROCHESTER
Civil Engineering and
Environmental Policy Director

The Deputy Chief Engineer
The Scottish Office Industry Department
Roads Directorate
New St Andrew's House
Edinburgh EH1 3TG

J INNES
Deputy Chief Engineer

The Director of Highways
Welsh Office
Y Swyddfa Gymreig
Government Buildings
Ty Glas Road
Llanishen
Cardiff CF4 5PL

K J THOMAS
Director of Highways

Chief Engineer - Roads Service
Department of the Environment
for Northern Ireland
Roads Service Headquarters
Clarence Court
10-18 Adelaide Street
Belfast BT2 8GB

W J McCOUBREY
Chief Engineer - Roads Service